

REV	DESCRIPTION OF REVISION	E.C.N.	BY	APPROVED	DATE
A	EYELET WIDTH WAS .120 X .305 & BODY .105 X .290		E.T.W.	E.T.W.	11-30-07

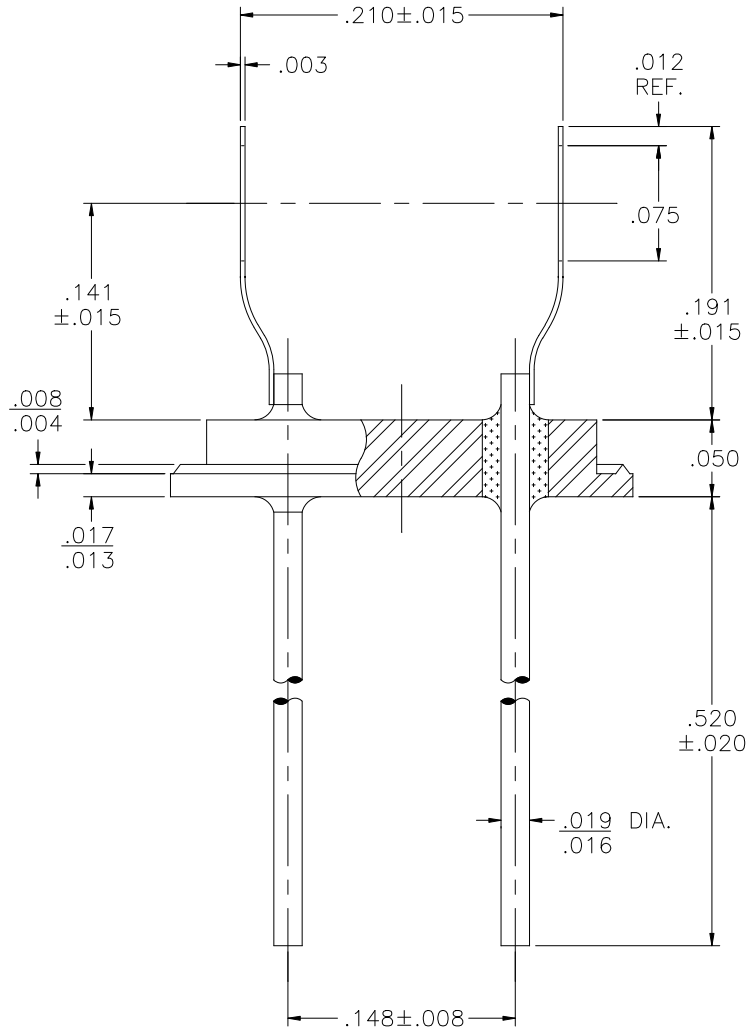
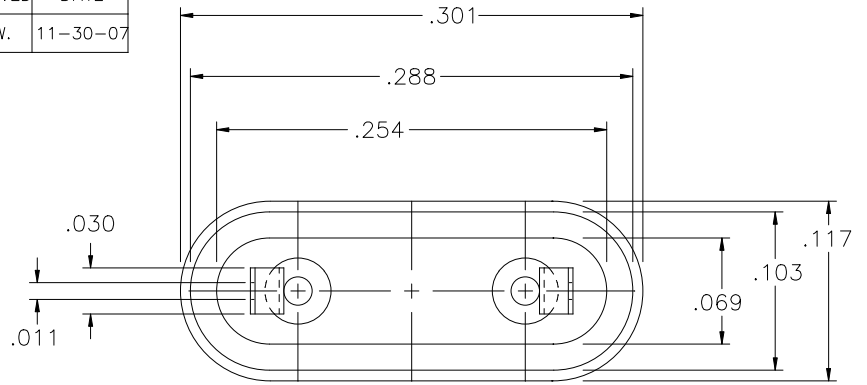

MATERIAL:

EYELET - 1010 C.R.S. OR EQUAL.
 GLASS - 9013 OR EQUAL.
 LEADS - ASTM F-30, 52 ALLOY.
 MOUNT - C770 NICKEL SILVER, FULL HARD.

PLATING:

1. OPTION: RoHS COMPLIANT ELECTROLESS NICKEL PLATE OF 100 MICROINCHES MINIMUM FINAL PLATE.
2. OPTION: RoHS COMPLIANT ELECTROLESS NICKEL PLATE OF 100 MICROINCHES MINIMUM FOLLOWED BY A RoHS COMPLIANT LEAD FREE SOLDER COAT, ON LEADS ONLY.
3. OPTION: RoHS COMPLIANT ELECTROLESS NICKEL PLATE OF 100 MICROINCHES MINIMUM FOLLOWED BY A GOLD FLASH OF .99999 PURE 24 KARAT GOLD UP TO A MAX. OF 8 MICROINCHES.

DRAWN BY: E.T.W. 08-15-07		MATERIAL: SEE ABOVE		TOLERANCING PER ANSI Y14.5 .X ±.005 .XXX ±.005 .XX ±.005 ANG ±5° UNLESS OTHERWISE SPECIFIED		 6700 W. 47th TERR. MISSION, KS. 66203 TEL: 913-432-2487 FAX: 913-432-0570		
CHECKED BY:		APP. SPECS	SUPERSEDES	NEXT ASSY	SCALE: 8:1			FINISH: UNLESS OTHERWISE SPECIFIED
APPROVED BY:		TITLE: HC-45/U RESISTACE WELD W/ SLOT MOUNT				FILE: VA00018E		PAGE 1 OF 1

A