

| REV | DESCRIPTION OF REVISION | E.C.N. | BY | APPROVED | DATE |
|-----|-------------------------|--------|----|----------|------|
|-----|-------------------------|--------|----|----------|------|

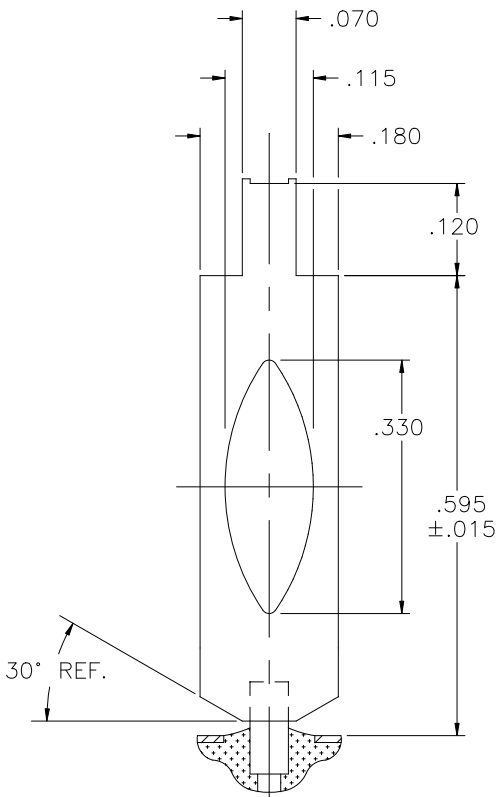
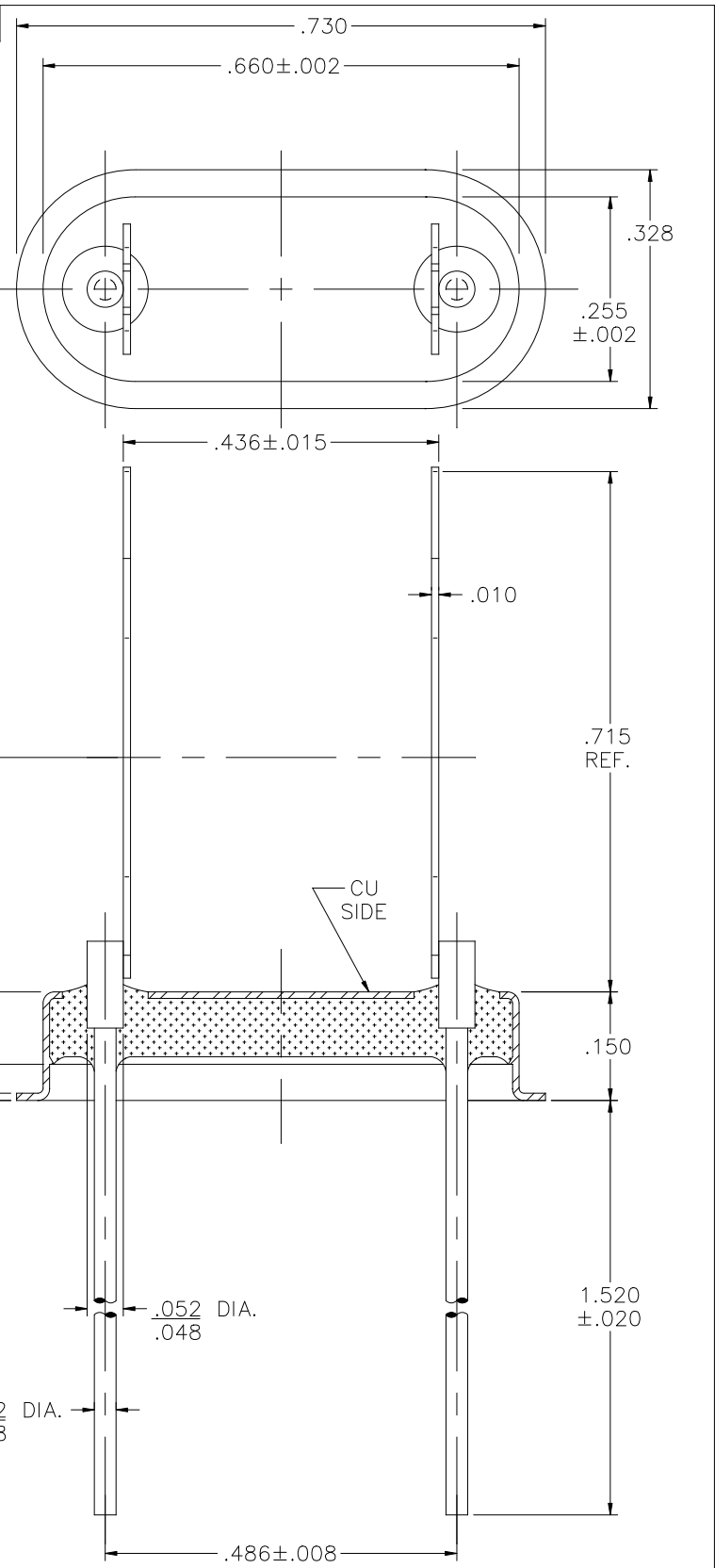

MATERIAL:

EYELET- 30/70 COPPER CLAD KOVAR.
 GLASS - 7052 OR EQUAL.
 LEADS - ASTM F-15 ALLOY, KOVAR.
 MOUNT- 302 S.S. 1/2 HARD TEMPER.

PLATING:

1. OPTION: RoHS COMPLIANT ELECTROLESS NICKEL PLATE OF 100 MICROINCHES MINIMUM FINAL PLATE.
2. OPTION: RoHS COMPLIANT ELECTROLESS NICKEL PLATE OF 100 MICROINCHES MINIMUM FOLLOWED BY A RoHS COMPLIANT LEAD FREE SOLDER COAT, ON LEADS ONLY.
3. OPTION: RoHS COMPLIANT ELECTROLESS NICKEL PLATE OF 100 MICROINCHES MINIMUM FOLLOWED BY A GOLD FLASH OF .99999 PURE 24 KARAT GOLD UP TO A MAX. OF 8 MICROINCHES.

| | | | | | | |
|---------------------------------|--|------------|------------|----------------------------|--|--|
| DRAWN BY: E.T.W. 11-02-07 | MATERIAL: SEE ABOVE | | | TOLERANCING PER ANSI Y14.5 | |  Legacy Technologies Inc. 6700 W. 47th TERR. MISSION, KS. 66203 TEL: 913-432-2487 FAX: 913-432-0570 |
| | CHECKED BY: | APP. SPECS | SUPERSEDES | NEXT ASSY | .X ±.005 .XXX ±.005 .XX ±.005 ANG ±5° UNLESS OTHERWISE SPECIFIED | |
| APPROVED BY: | TITLE: HC-47/U BUTT WELD W/ SLOTTED MOUNT FOR AROUND .535 DIA. BLANK | | | SCALE: 4:1 | FINISH: UNLESS OTHERWISE SPECIFIED | PART NUMBER: CW-109-BW-A -WSM-023 W/IS RoHS |
| | | | | | FILE: JC00037A | PAGE 1 OF 1 |