

THE INFORMATION CONTAINED IN THIS DRAWING IS THE SOLE PROPERTY OF LEGACY TECHNOLOGIES, INC. ANY REPRODUCTION IN PART OR WHOLE WITHOUT THE WRITTEN PERMISSION OF LEGACY TECHNOLOGIES, INC. IS PROHIBITED.

REV	DESCRIPTION OF REVISION	E.C.N.	BY	APPROVED	DATE
A	ADDED CLIP ON PIN 1		E.T.W.	E.T.W.	08-13-98
B	CHAIR MOUNT O.A.H. WAS .087 MAX.		E.T.W.	E.T.W.	12-09-98
C	CHAIR MOUNT MAT'L WAS LISTED AS PURE NICKEL ALLOY		E.T.W.	E.T.W.	05-08-00

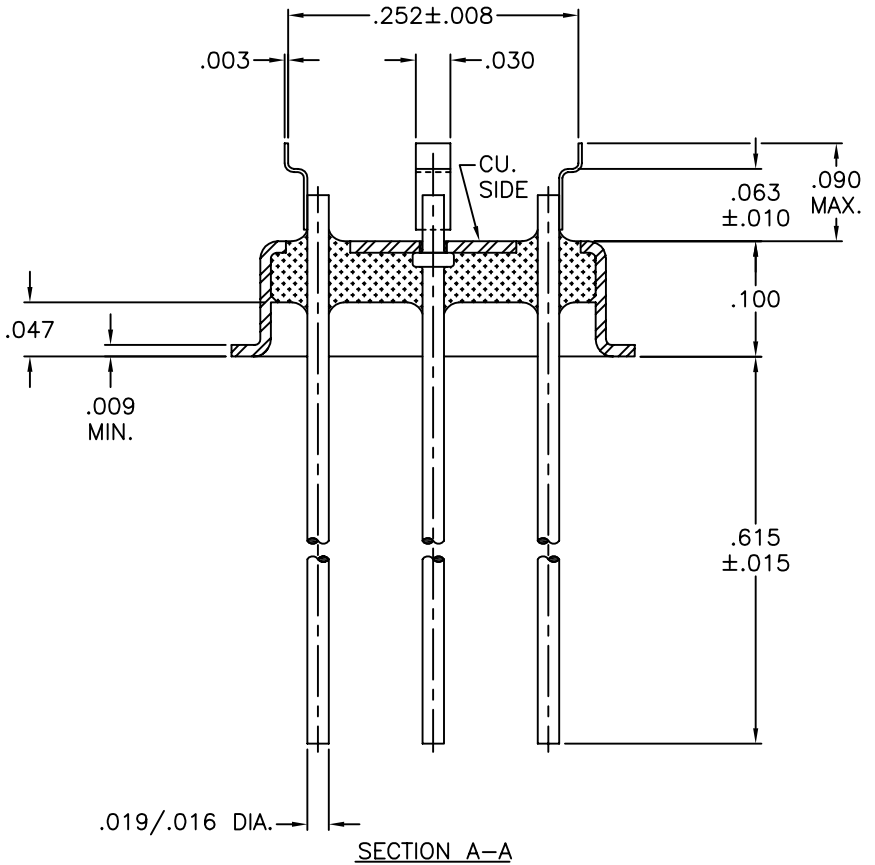
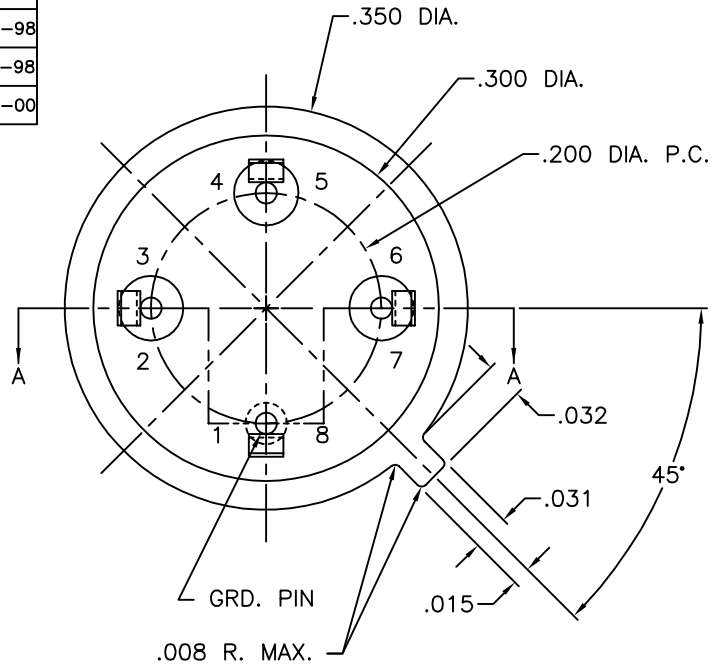

**MATERIAL:**

EYELET - 30/70 COPPER CLAD KOVAR.  
 GLASS - 7052 OR EQUAL, OPAQUE.  
 LEADS - ASTM F-15 ALLOY, KOVAR.  
 MOUNT - 200 NICKEL, 1/2 HARD.

**PLATING:**

1. ELECTROLESS NICKEL FINAL PLATE OF 100 MICROINCHES MINIMUM.
2. OPTIONAL SOLDER COAT ON LEADS ONLY PER MIL-STD QQ-S-571-D TIN LEAD ALLOY.
3. OPTIONAL GOLD FLASH .99999 PURE 24 KARAT GOLD UP TO A MAX. OF 8 MICROINCHES OVER THE ELECTROLESS NICKEL FINAL PLATE.

DRAWN BY: E.T.W. 06-22-98	MATERIAL: SEE ABOVE			TOLERANCING PER ANSI Y14.5 .X ± .005 .XXX ± .005 .XX ± .005 ANG ± 5° UNLESS OTHERWISE SPECIFIED		 Legacy Technologies Inc. 6700 W. 47th TERR. MISSION, KS. 66203 TEL: 913-432-2487 FAX: 913-432-0570
	CHECKED BY: E.T.W. 06-22-98	APP. SPECS	SUPERSEDES	NEXT ASSY	SCALE: 6:1	
APPROVED BY:	TITLE: HC-35/U NARROW FLANGE TYPE W/ CN-CLIP				PART NUMBER: CW-T05-G-CN330D	C
					FILE: GA00047	PAGE 1 of 1