

REV	DESCRIPTION OF REVISION	E.C.N.	BY	APPROVED	DATE
-----	-------------------------	--------	----	----------	------

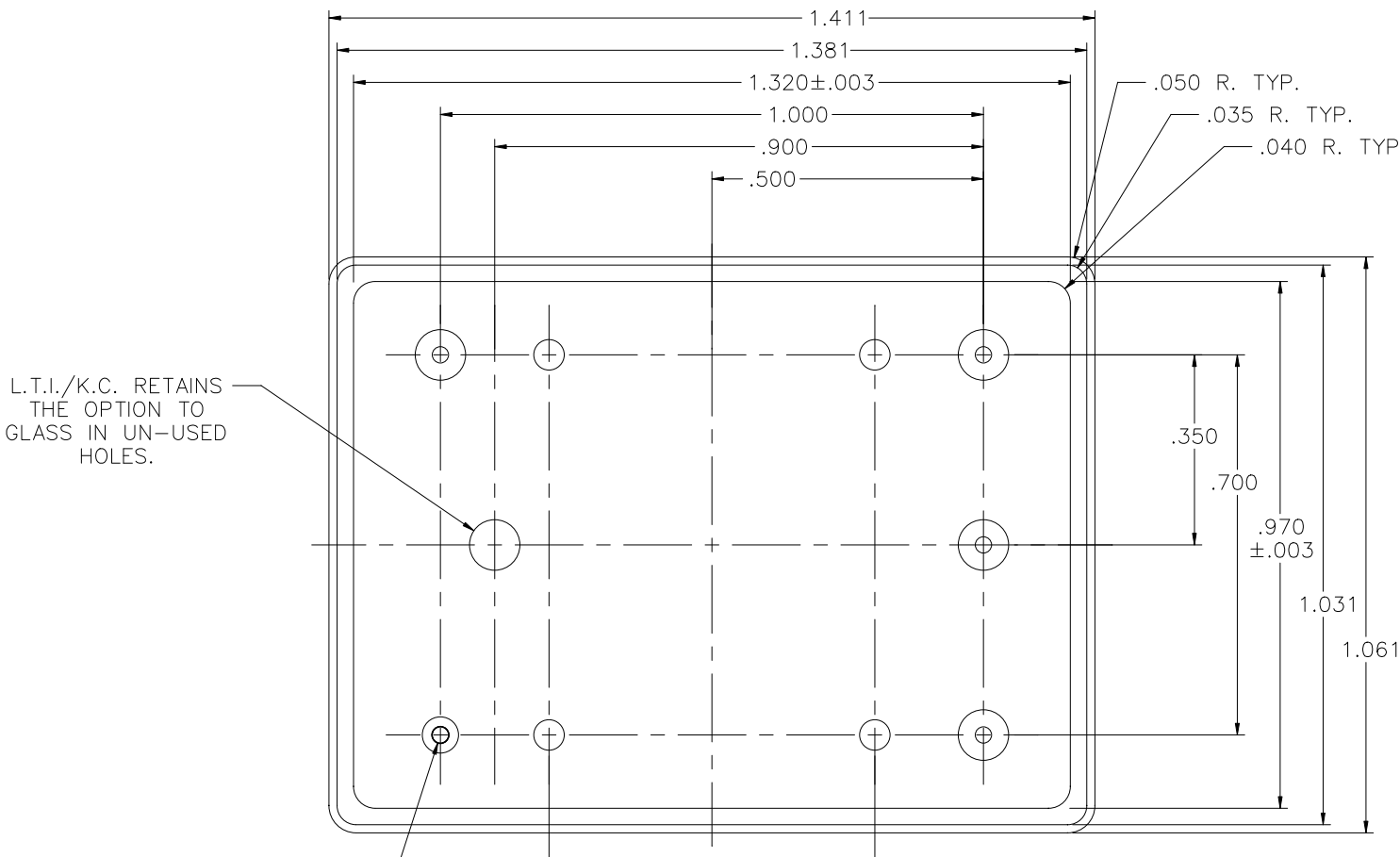

L.T.I./K.C. RETAINS THE OPTION TO GLASS IN UN-USED HOLES.

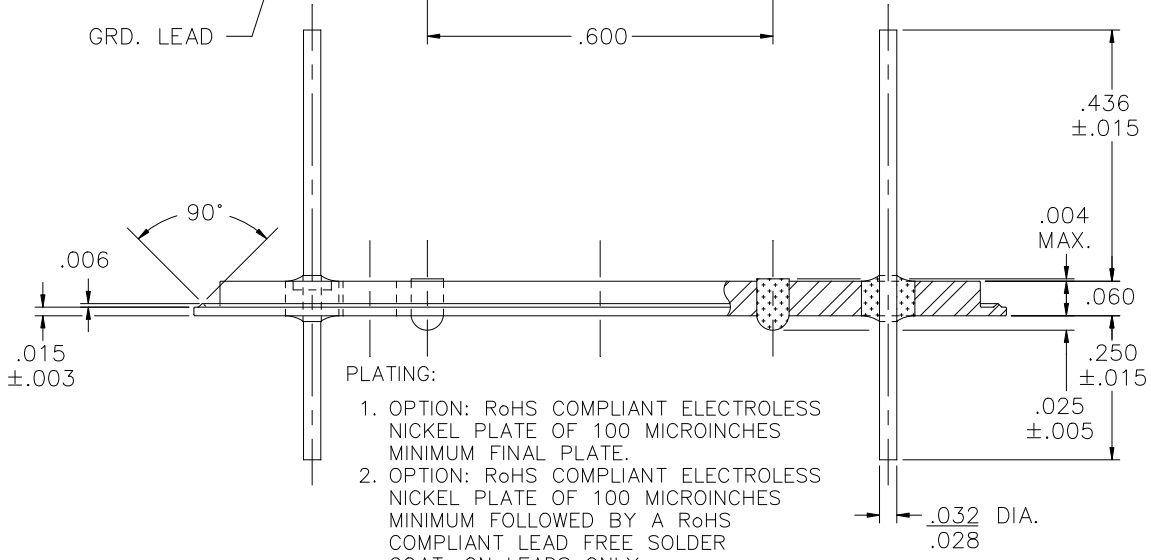

- PLATING:
1. OPTION: RoHS COMPLIANT ELECTROLESS NICKEL PLATE OF 100 MICROINCHES MINIMUM FINAL PLATE.
 2. OPTION: RoHS COMPLIANT ELECTROLESS NICKEL PLATE OF 100 MICROINCHES MINIMUM FOLLOWED BY A RoHS COMPLIANT LEAD FREE SOLDER COAT, ON LEADS ONLY.
 3. OPTION: RoHS COMPLIANT ELECTROLESS NICKEL PLATE OF 100 MICROINCHES MINIMUM FOLLOWED BY A GOLD FLASH OF .99999 PURE 24 KARAT GOLD UP TO A MAX. OF 8 MICROINCHES.

MATERIAL:

- EYELET - 1010 C.R.S. OR EQUAL.
- GLASS - 7052 OR EQUAL.
- LEADS - ASTM F-15 ALLOY, KOVAR.
- BRAZE - 65% AG, 20% CU AND 15% PB.

DRAWN BY: E.T.W. 03-21-11		MATERIAL: SEE ABOVE		TOLERANCING PER ANSI Y14.5 .X ±.005 .XXX ±.005 .XX ±.005 ANG ±5° UNLESS OTHERWISE SPECIFIED		 <p>6700 W. 47th TERR. MISSION, KS. 66203 TEL: 913-432-2487 FAX: 913-432-0570</p>
CHECKED BY:	APP. SPECS	SUPERSEDES	NEXT ASSY	SCALE: 3:1	FINISH: UNLESS OTHERWISE SPECIFIED	
APPROVED BY:	TITLE: RESISTANCE WELD EUROPACKAGE				FILE: UL00001B	PAGE 1 OF 1