

REV	DESCRIPTION OF REVISION	E.C.N.	BY	APPROVED	DATE
A	CORRECTED PATENT NO.		E.T.W.	M.F.	12-01-06

**PATENT NO.:**  
**US6.229.088**

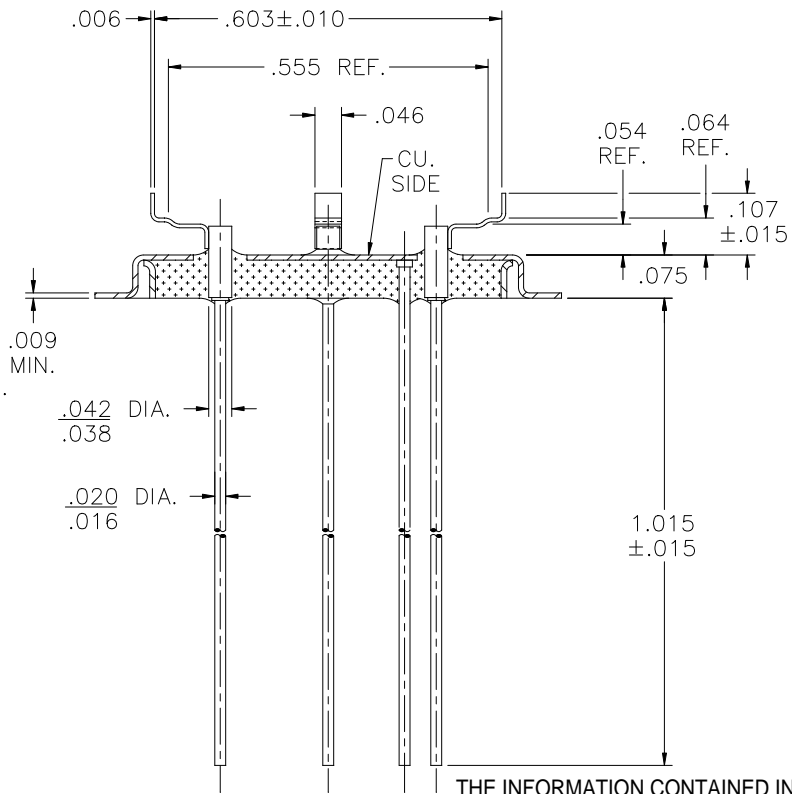
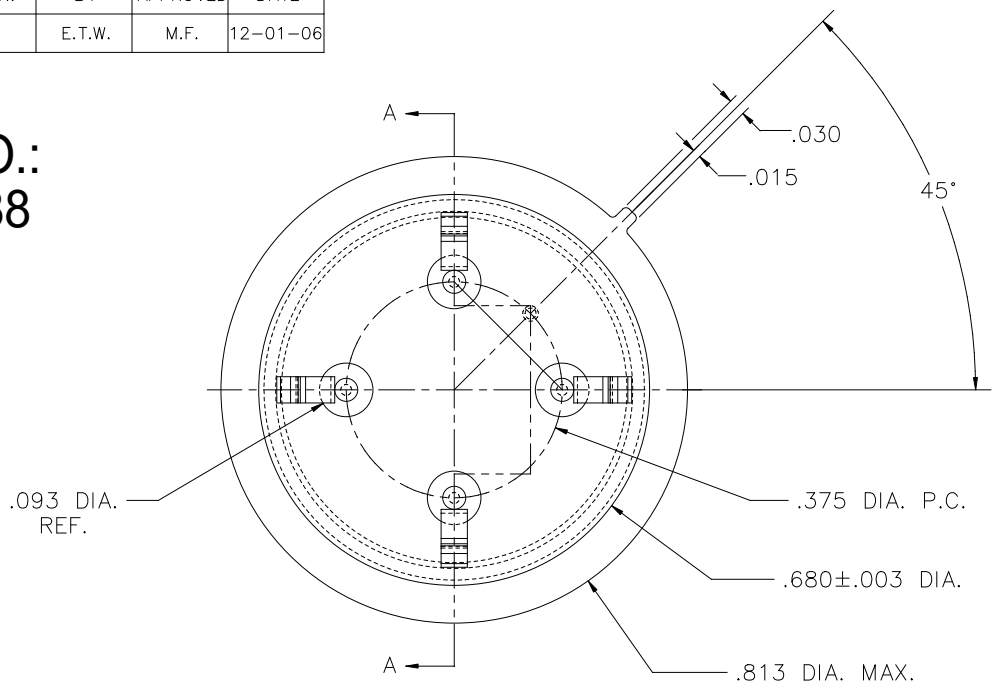

**NOTE:**

POST HEIGHT IS SPECIFIED OFF THE HIGHEST POINT ON THE POST SIDE.

**MATERIAL:**

- EYELET - 30/70 COPPER CLAD KOVAR.
- SEAL RING - ASTM F-15 ALLOY, KOVAR.
- GLASS - 7052 OR EQUAL, OPAQUE.
- LEADS - ASTM F-15 ALLOY, KOVAR.
- MOUNT - NICKEL.

**PLATING:**

1. OPTION: RoHS COMPLIANT ELECTROLESS NICKEL PLATE OF 100 MICROINCHES MINIMUM FINAL PLATE.
2. OPTION: RoHS COMPLIANT ELECTROLESS NICKEL PLATE OF 100 MICROINCHES MINIMUM FOLLOWED BY A RoHS COMPLIANT SOLDER COAT OF A TIN ALLOY, ON LEADS ONLY.
3. OPTION: RoHS COMPLIANT ELECTROLESS NICKEL PLATE OF 100 MICROINCHES MINIMUM FOLLOWED BY A GOLD FLASH OF .99999 PURE 24 KARAT GOLD UP TO A MAX. OF 8 MICROINCHES.

THE INFORMATION CONTAINED IN THIS DRAWING IS THE SOLE PROPERTY OF LEGACY TECHNOLOGIES, INC.

ANY REPRODUCTION IN PART OR WHOLE WITHOUT THE WRITTEN PERMISSION OF LEGACY TECHNOLOGIES, INC. IS PROHIBITED.

DRAWN BY: E.T.W. 01-04-06	MATERIAL: SEE ABOVE			TOLERANCING PER ANSI Y14.5 .X ±.005 .XXX ±.005 .XX ±.005 ANG ±5° UNLESS OTHERWISE SPECIFIED		 Legacy Technologies Inc.	6700 W. 47th TERR. MISSION, KS. 66203 TEL: 913-432-2487 FAX: 913-432-0570	
CHECKED BY:	APP. SPECS	SUPERSEDES	NEXT ASSY	SCALE: 3:1	FINISH: UNLESS OTHERWISE SPECIFIED		PART NUMBER:	A
APPROVED BY:	TITLE: L.T.I. KANE P/N: 800-0817-1390-919 RoHS REF. HC-40/U REF. LOW PROFILE W/ CHAIR MOUNT (KANE MOUNT P/N: 1390)				PART NUMBER: CWLP-40-BW-A-CN646F RoHS		FILE:	PAGE 1 of 1