

REV	DESCRIPTION OF REVISION	E.C.N.	BY	APPROVED	DATE
A	ADDED P.H., CORRECTED MOUNT MAT'L.		E.T.W.	D.B.	02-06-06
B	CORRECTED MAT'L WAS 7052 OR EQUAL ASTM F-15 ALLOY, KOVAR		E.T.W.		02-10-06

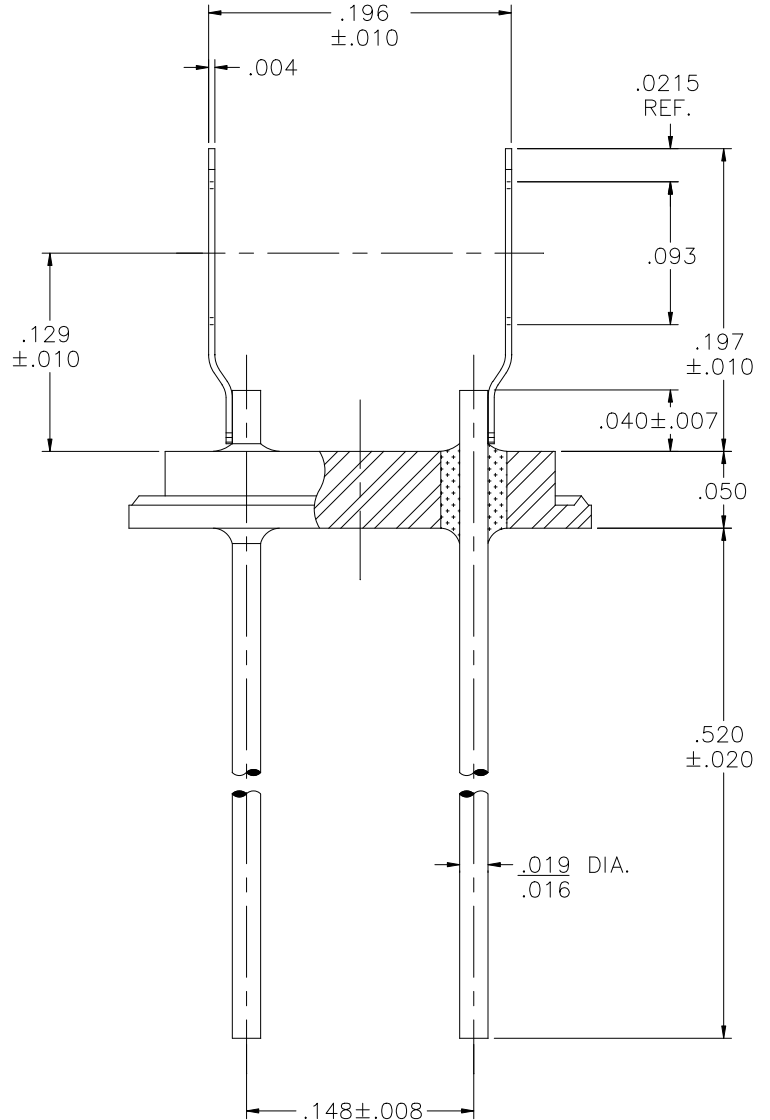
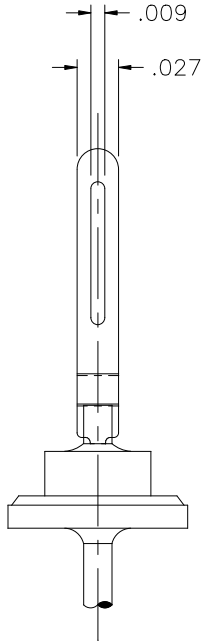
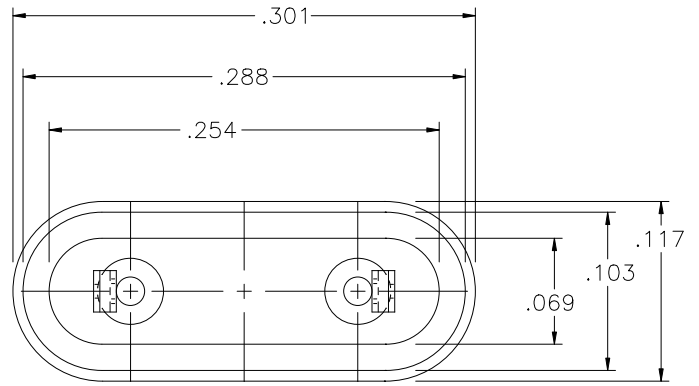

MATERIAL:

EYELET - 1010 C.R.S. OR EQUAL.
 GLASS - 9013 OR EQUAL.
 LEADS - ASTM F-30, 52 ALLOY.
 MOUNT - C770 NICKEL SILVER.

PLATING:

1. OPTION: RoHS COMPLIANT ELECTROLESS NICKEL PLATE OF 100 MICROINCHES MINIMUM FINAL PLATE.
2. OPTION: RoHS COMPLIANT ELECTROLESS NICKEL PLATE OF 100 MICROINCHES MINIMUM FOLLOWED BY A RoHS COMPLIANT LEAD FREE SOLDER COAT, ON LEADS ONLY.
3. OPTION: RoHS COMPLIANT ELECTROLESS NICKEL PLATE OF 100 MICROINCHES MINIMUM FOLLOWED BY A GOLD FLASH OF .99999 PURE 24 KARAT GOLD UP TO A MAX. OF 8 MICROINCHES.

DRAWN BY: E.T.W. 06-21-01		MATERIAL: SEE ABOVE		TOLERANCING PER ANSI Y14.5 .X ±.005 .XXX ±.005 .XX ±.005 ANG ±5° UNLESS OTHERWISE SPECIFIED		 6700 W. 47th TERR. MISSION, KS. 66203 TEL: 913-432-2487 FAX: 913-432-0570		
CHECKED BY:		APP. SPECS ANDERSON P/N: 015-134-00728 REV. A REF.	SUPERSEDES	NEXT ASSY	SCALE: 8:1			FINISH: UNLESS OTHERWISE SPECIFIED
APPROVED BY:		TITLE: L.T.I. / KANE P/N: 220-0105-1231-819 HC-45/U RESISTACE WELD W/ WELD SLOT MOUNT				FILE: VA00128B		PAGE 1 of 1

B