

REV	DESCRIPTION OF REVISION	E.C.N.	BY	APPROVED	DATE
-----	-------------------------	--------	----	----------	------

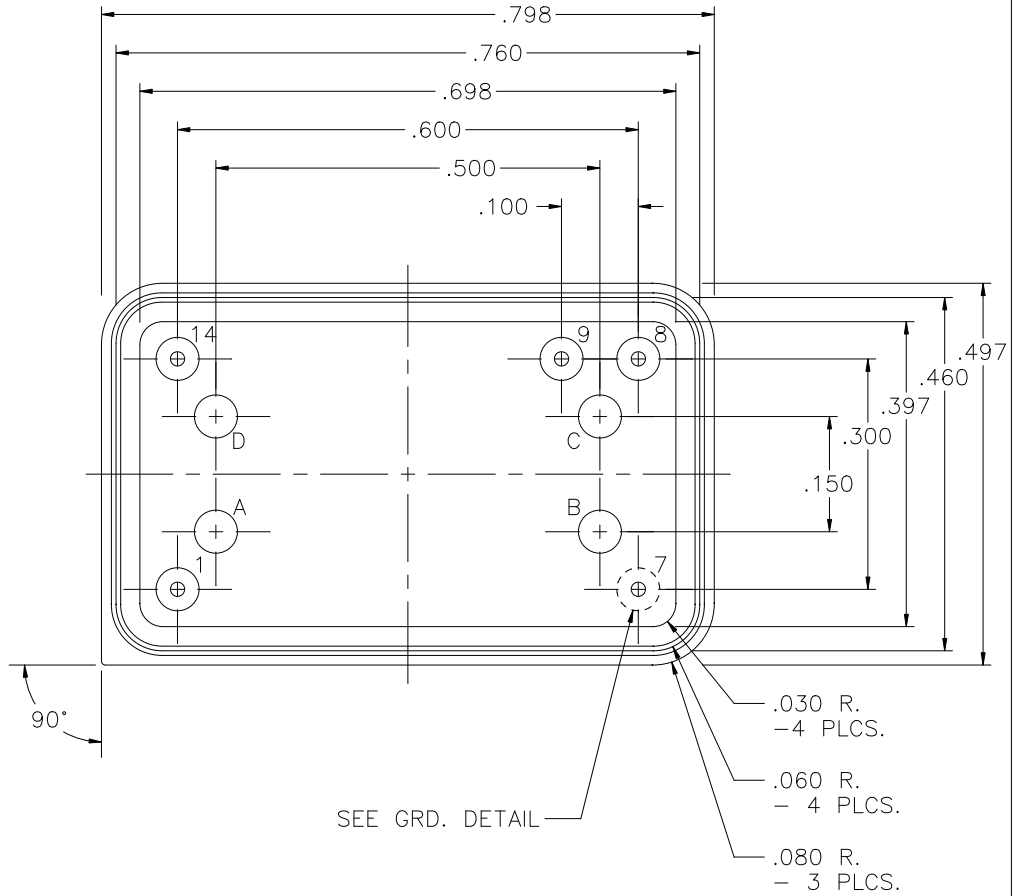

PIN 7 GRD. DETAIL
SCALE: 8:1

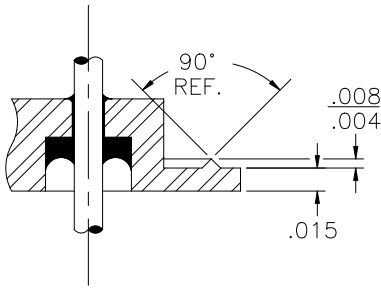



MATERIAL:

EYELET - 1010 C.R.S. OR EQUAL.
GLASS - 7052 OR EQUAL.
LEADS - ASTM F-15 ALLOY, KOVAR.
BRAZE - BT VTG AG. CU. EUTECTIC.

PLATING:

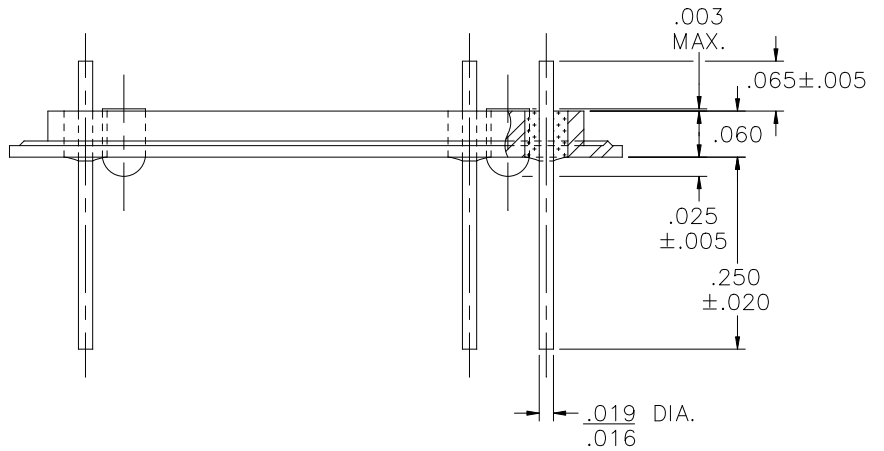
- OPTION: RoHS COMPLIANT ELECTROLESS NICKEL PLATE OF 100 MICROINCHES MINIMUM FINAL PLATE.
- OPTION: RoHS COMPLIANT ELECTROLESS NICKEL PLATE OF 100 MICROINCHES MINIMUM FOLLOWED BY A RoHS COMPLIANT LEAD FREE SOLDER COAT, ON LEADS ONLY.
- OPTION: RoHS COMPLIANT ELECTROLESS NICKEL PLATE OF 100 MICROINCHES MINIMUM FOLLOWED BY A GOLD FLASH OF .99999 PURE 24 KARAT GOLD UP TO A MAX. OF 8 MICROINCHES.



DRAWN BY: E.T.W. 03-11-11	MATERIAL: SEE ABOVE	TOLERANCING PER ANSI Y14.5 .X ±.005 .XXX ±.005 .XX ±.005 ANG ±5° UNLESS OTHERWISE SPECIFIED		 6700 W. 47th TERR. MISSION, KS. 66203 TEL: 913-432-2487 FAX: 913-432-0570	
CHECKED BY:	APP. SPECS	SUPERSEDES	NEXT ASSY		PART NUMBER: RR-498798-HY RoHS
APPROVED BY:	TITLE: .498x.798 D.I.P. 5 PIN, P7G, 4 S.O. .025 TALL .150x.500 GRID, .065 PH. .250 LL.	SCALE: 4:1		FINISH: UNLESS OTHERWISE SPECIFIED	FILE: UB00053F
				PAGE	1 OF 1