

REV	DESCRIPTION OF REVISION	E.C.N.	BY	APPROVED	DATE
A	ADDED MOUNT TEMPER, EYELET WD. WAS .120X.305, BODY .105X.290		E.T.W.		11-30-07

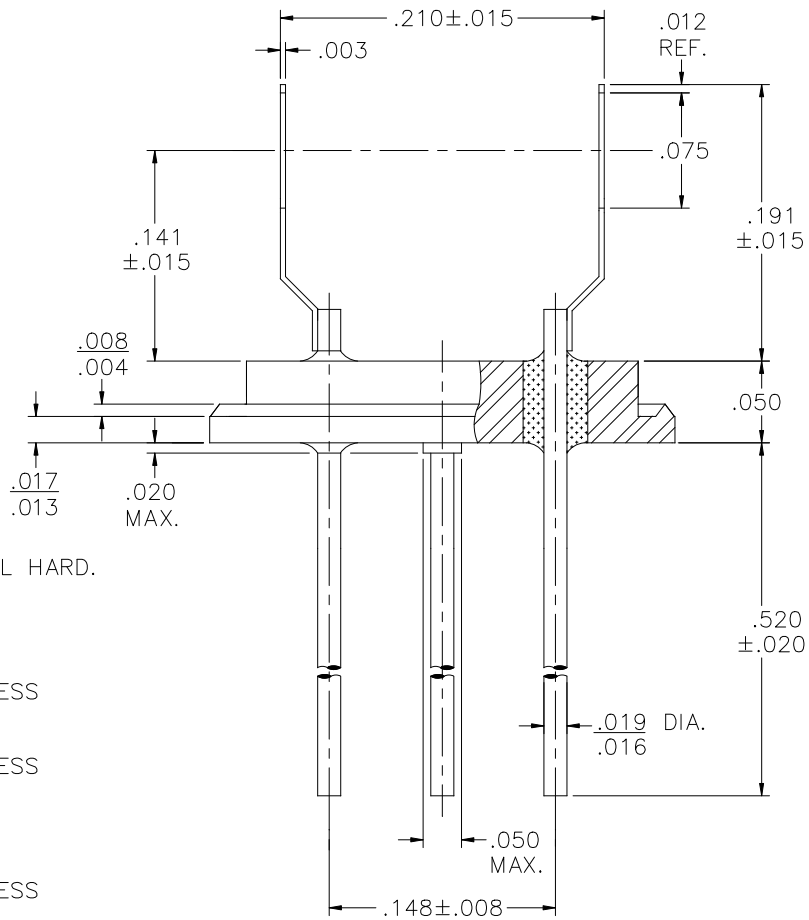
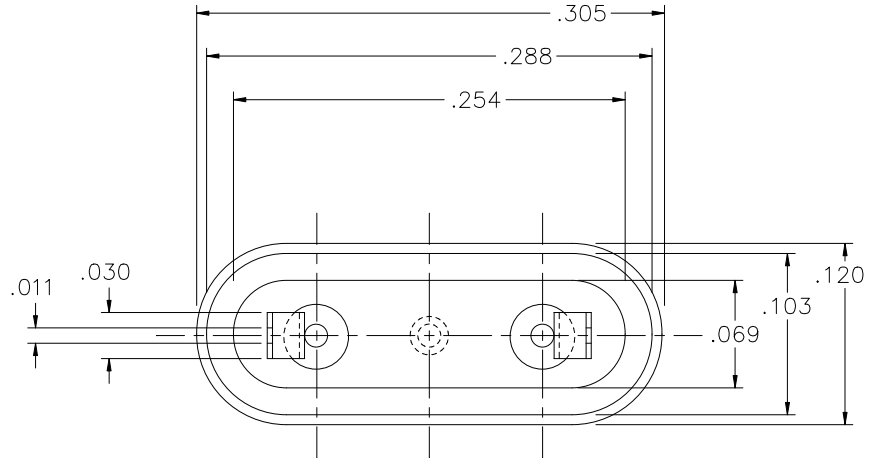

MATERIAL:

EYELET - 1010 C.R.S. OR EQUAL.
 GLASS - 9013 OR EQUAL.
 LEADS - ASTM F-30, 52 ALLOY.
 MOUNTS - C770 NICKEL SILVER, FULL HARD.

PLATING:

- OPTION: RoHS COMPLIANT ELECTROLESS NICKEL PLATE OF 100 MICROINCHES MINIMUM FINAL PLATE.
- OPTION: RoHS COMPLIANT ELECTROLESS NICKEL PLATE OF 100 MICROINCHES MINIMUM FOLLOWED BY A RoHS COMPLIANT LEAD FREE SOLDER COAT, ON LEADS ONLY.
- OPTION: RoHS COMPLIANT ELECTROLESS NICKEL PLATE OF 100 MICROINCHES MINIMUM FOLLOWED BY A GOLD FLASH OF .99999 PURE 24 KARAT GOLD UP TO A MAX. OF 8 MICROINCHES.

DRAWN BY: E.T.W. 06-23-08		MATERIAL: SEE ABOVE		TOLERANCING PER ANSI Y14.5 .X ±.005 .XXX ±.005 .XX ±.005 ANG ±5° UNLESS OTHERWISE SPECIFIED		 6700 W. 47th TERR. MISSION, KS. 66203 TEL: 913-432-2487 FAX: 913-432-0570	
CHECKED BY:		APP. SPECS MTRON/PTI P/N: 101698-R REV. A	SUPSEDES	NEXT ASSY	SCALE: N.T.S.		
APPROVED BY:		TITLE: HC-45/U RESISTANCE WELD W/ SLOT MOUNT FOR .218 DIA. BLANK				PART NUMBER: RR-45-CGF-D-WSM018A B.210 RoHS	
		FILE: VA00106C		PAGE 1 OF 1		A	