

REV	DESCRIPTION OF REVISION	E.C.N.	BY	APPROVED	DATE
A	ADJUSTED PRINT TO NEW MOUNT TOOL.		E.T.W.	J.T.	04-30-09
B	ADDED DETAIL "B" FOR DIM. ON MOUNT & REMOVED .039 REF.		E.C.	E.T.W.	09-19-14
C	SEAL RING TO TOP EYELET ±.003 & RING TO BOT. OF FLG. .003 MAX.		E.C.	E.T.W.	04-09-15

PATENT NO.:
US6.229.088

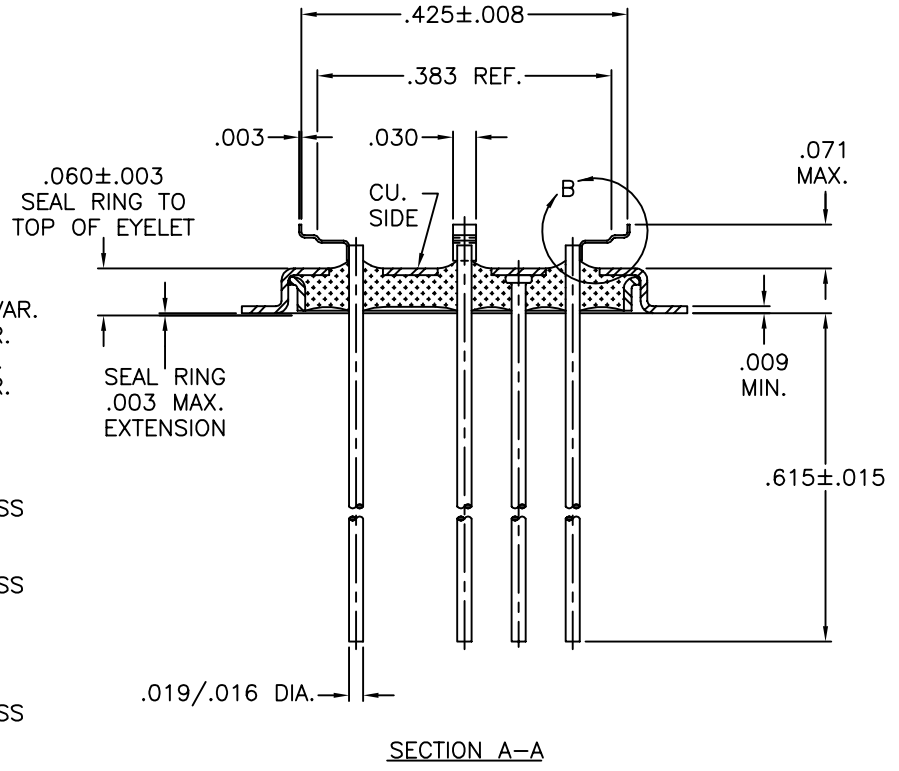
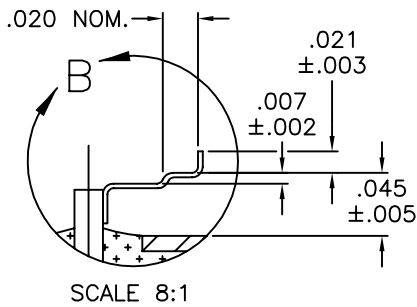
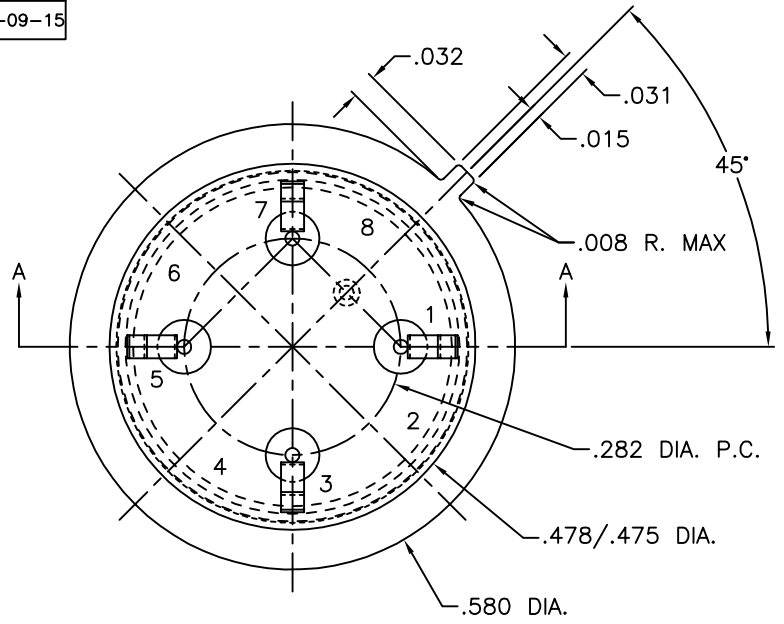

MATERIAL:
 EYELET - 30/70 COPPER CLAD KOVAR.
 SEAL RING - ASTM F-15 ALLOY, KOVAR.
 GLASS - 7052 OR EQUAL, OPAQUE.
 LEADS - ASTM F-15 ALLOY, KOVAR.
 MOUNT - 200 NICKEL, 1/2 HARD.

PLATING:

- OPTION: RoHS COMPLIANT ELECTROLESS NICKEL PLATE OF 100 MICROINCHES MINIMUM FINAL PLATE.
- OPTION: RoHS COMPLIANT ELECTROLESS NICKEL PLATE OF 100 MICROINCHES MINIMUM FOLLOWED BY A RoHS COMPLIANT LEAD FREE SOLDER COAT, ON LEADS ONLY.
- OPTION: RoHS COMPLIANT ELECTROLESS NICKEL PLATE OF 100 MICROINCHES MINIMUM FOLLOWED BY A GOLD FLASH OF .99999 PURE 24 KART GOLD UP TO A MAX. OF 8 MICROINCHES.

DRAWN BY: E.T.W. 12-12-07	MATERIAL: SEE ABOVE			TOLERANCING PER ANSI Y14.5 .X ± .005 .XXX ± .005 .XX ± .005 ANG ± 5° UNLESS OTHERWISE SPECIFIED		 Legacy Technologies Inc. 6700 W. 47th TERR. MISSION, KS. 66203 TEL: 913-432-2487 FAX: 913-432-0570
	CHECKED BY: E.T.W. 12-12-07	APP. SPECS	SUPERSEDES	NEXT ASSY	SCALE: 4:1	
APPROVED BY:	TITLE: HC-37/U WIDE FLANGE LOW PROFILE L.T.I. / KANE P/N: 500-0106-1364-919 RoHS W/ CHAIR MOUNT (KANE MOUNT P/N: 1364)				PART NUMBER: CWLP-T08-017D-CN330T RoHS	C
FILE: HE00014A					PAGE 1 of 1	