

REV	DESCRIPTION OF REVISION	E.C.N.	BY	APPROVED	DATE
A	P/N: -DB002B B.203, NOW B.194, .203±.015, .133±.010, .196±.015		E.T.W.		04-23-10

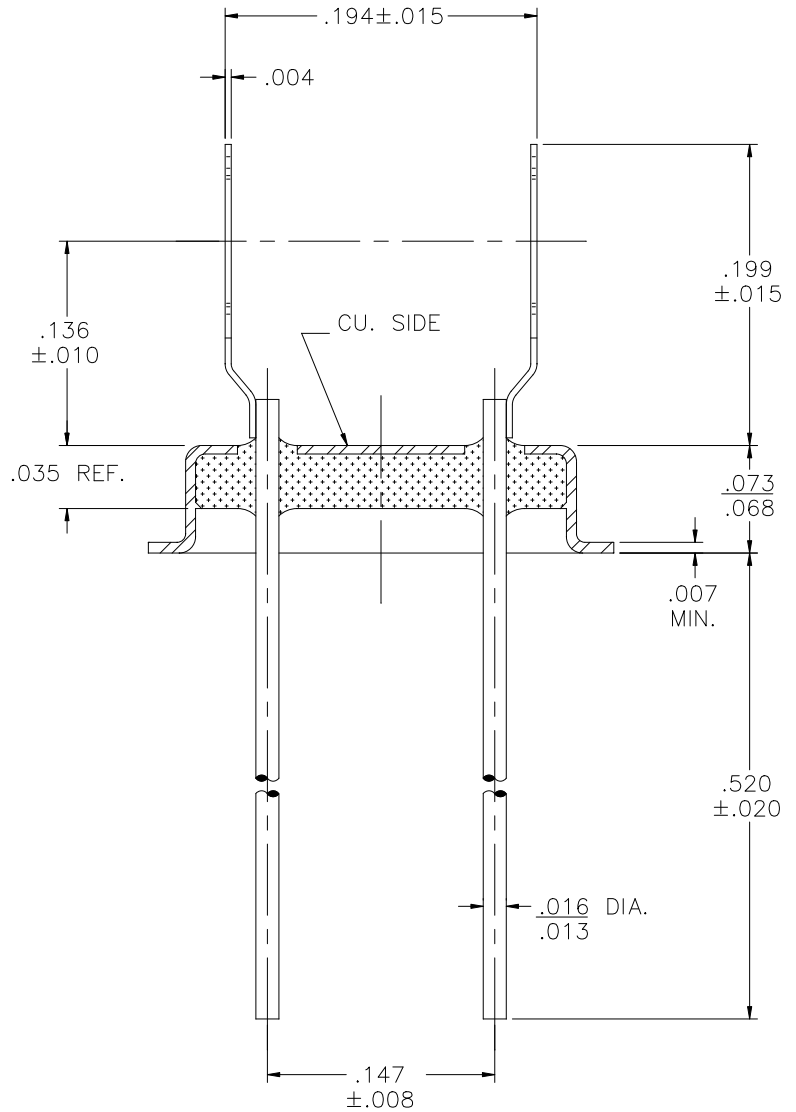
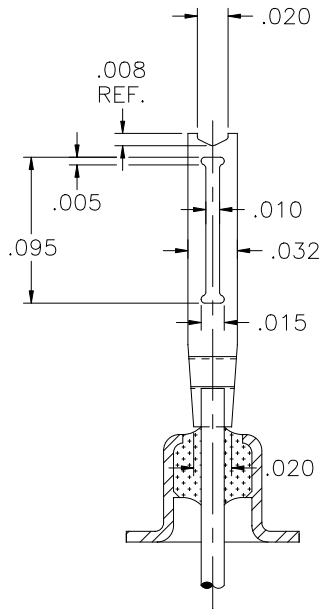
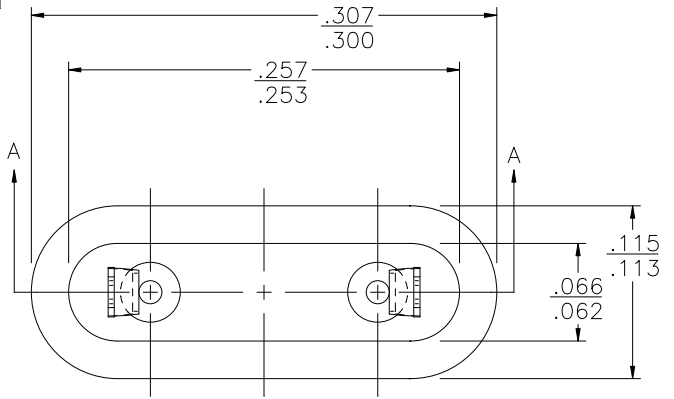

SECTION A-A

MATERIAL:

EYELET- 30/70 COPPER CLAD KOVAR.
GLASS - 7052 OR EQUAL.
LEADS - ASTM F-15 ALLOY, KOVAR.
MOUNT- C770 NICKEL SILVER, 1/2 HARD.

PLATING:

1. OPTION: RoHS COMPLIANT ELECTROLESS NICKEL PLATE OF 100 MICROINCHES MINIMUM FINAL PLATE.
2. OPTION: RoHS COMPLIANT ELECTROLESS NICKEL PLATE OF 100 MICROINCHES MINIMUM FOLLOWED BY A RoHS COMPLIANT LEAD FREE SOLDER COAT, ON LEADS ONLY.
3. OPTION: RoHS COMPLIANT ELECTROLESS NICKEL PLATE OF 100 MICROINCHES MINIMUM FOLLOWED BY A GOLD FLASH OF .99999 PURE 24 KARAT GOLD UP TO A MAX. OF 8 MICROINCHES.

DRAWN BY: E.T.W. 04-12-10	MATERIAL: SEE ABOVE			TOLERANCING PER ANSI Y14.5 .X ±.005 .XXX ±.005 .XX ±.005 ANG ±5° UNLESS OTHERWISE SPECIFIED		 Legacy Technologies Inc. 6700 W. 47th TERR. MISSION, KS. 66203 TEL: 913-432-2487 FAX: 913-432-0570	PART NUMBER: CW-45-015A-DB002B B.194 RoHS	A	
CHECKED BY:	APP. SPECS	SUPERSEDES	NEXT ASSY	SCALE: 8:1	FINISH: UNLESS OTHERWISE SPECIFIED				FILE: MB00057A
APPROVED BY:	TITLE: HC-45/U W/ DOG BONE MOUNT FOR A .220 DIA. BLANK								