

REV	DESCRIPTION OF REVISION	E.C.N.	BY	APPROVED	DATE
C	FILE NO.: MC00011.SKD		E.T.W.	E.T.W.	02-10-05
D	CORRECTED PATENT NO.		E.T.W.	M.F.	12-01-06
E	SEAL RING TO TOP EYELET ±.003 & RING TO BOT. OF FLG. .003 MAX.		E.C.	E.T.W.	04-09-15

PATENT NO.:
US6.229.088

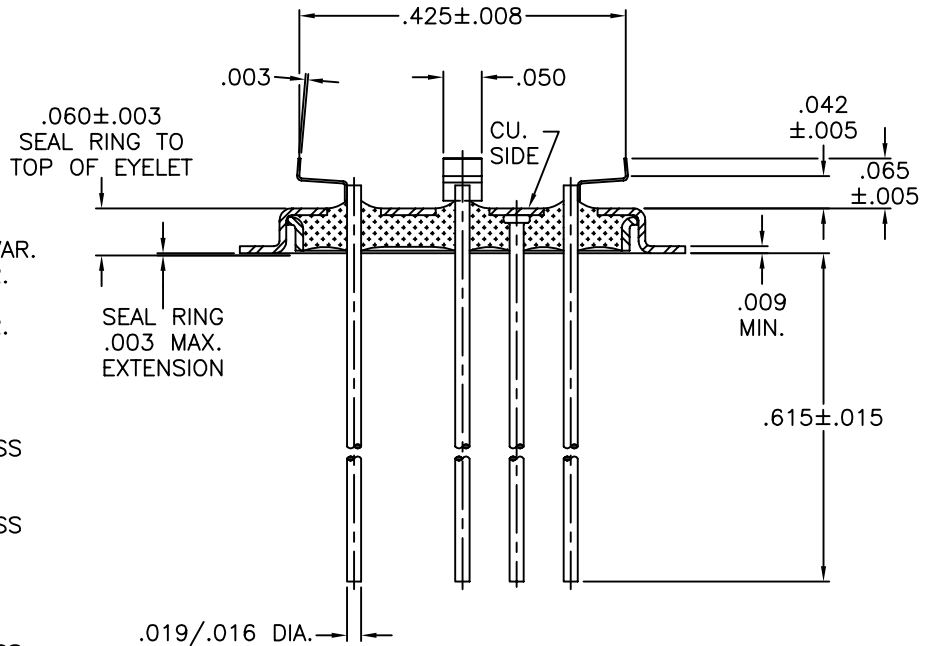
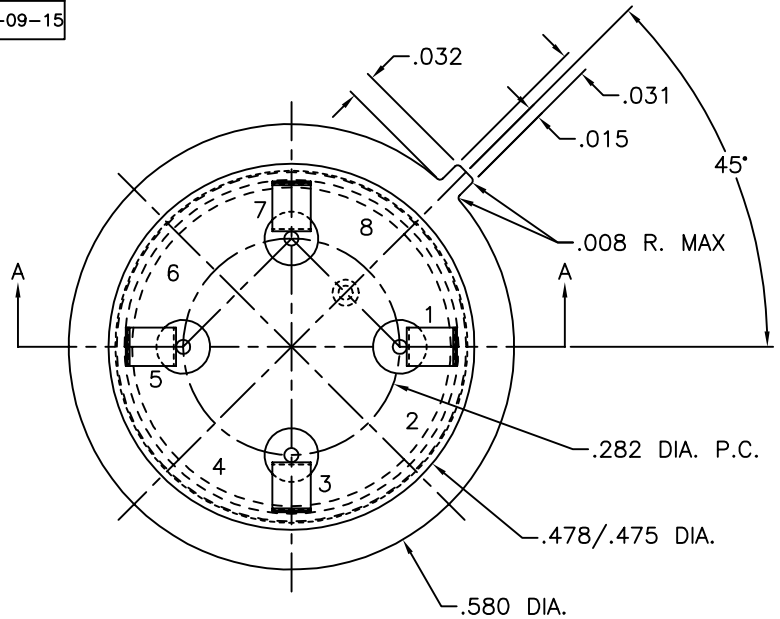

MATERIAL:

- EYELET - 30/70 COPPER CLAD KOVAR.
- SEAL RING - ASTM F-15 ALLOY, KOVAR.
- GLASS - 7052 OR EQUAL, OPAQUE.
- LEADS - ASTM F-15 ALLOY, KOVAR.
- MOUNT - 200 NICKEL, 1/4 HARD.

PLATING:

1. OPTION: RoHS COMPLIANT ELECTROLESS NICKEL PLATE OF 100 MICROINCHES MINIMUM FINAL PLATE.
2. OPTION: RoHS COMPLIANT ELECTROLESS NICKEL PLATE OF 100 MICROINCHES MINIMUM FOLLOWED BY A RoHS COMPLIANT LEAD FREE SOLDER COAT, ON LEADS ONLY.
3. OPTION: RoHS COMPLIANT ELECTROLESS NICKEL PLATE OF 100 MICROINCHES MINIMUM FOLLOWED BY A GOLD FLASH OF .99999 PURE 24 KART GOLD UP TO A MAX. OF 8 MICROINCHES.

SECTION A-A

DRAWN BY: E.T.W. 12-21-05		MATERIAL: SEE ABOVE		TOLERANCING PER ANSI Y14.5 .X ± .005 .XXX ± .005 .XX ± .005 ANG ± 5° UNLESS OTHERWISE SPECIFIED		 Legacy Technologies Inc. 6700 W. 47th TERR. MISSION, KS. 66203 TEL: 913-432-2487 FAX: 913-432-0570		
CHECKED BY: E.T.W. 12-21-05		APP. SPECS	SUPERSEDES	NEXT ASSY	SCALE: 4:1			FINISH: UNLESS OTHERWISE SPECIFIED <input checked="" type="checkbox"/>
APPROVED BY:		TITLE: HC-37/U WIDE FLANGE LOW PROFILE L.T.I. / KANE P/N: 500-0106-1371-919 RoHS W/ CHAIR MOUNT				FILE: HE00003B		PAGE 1 of 1