

REV	DESCRIPTION OF REVISION	E.C.N.	BY	APPROVED	DATE
-----	-------------------------	--------	----	----------	------

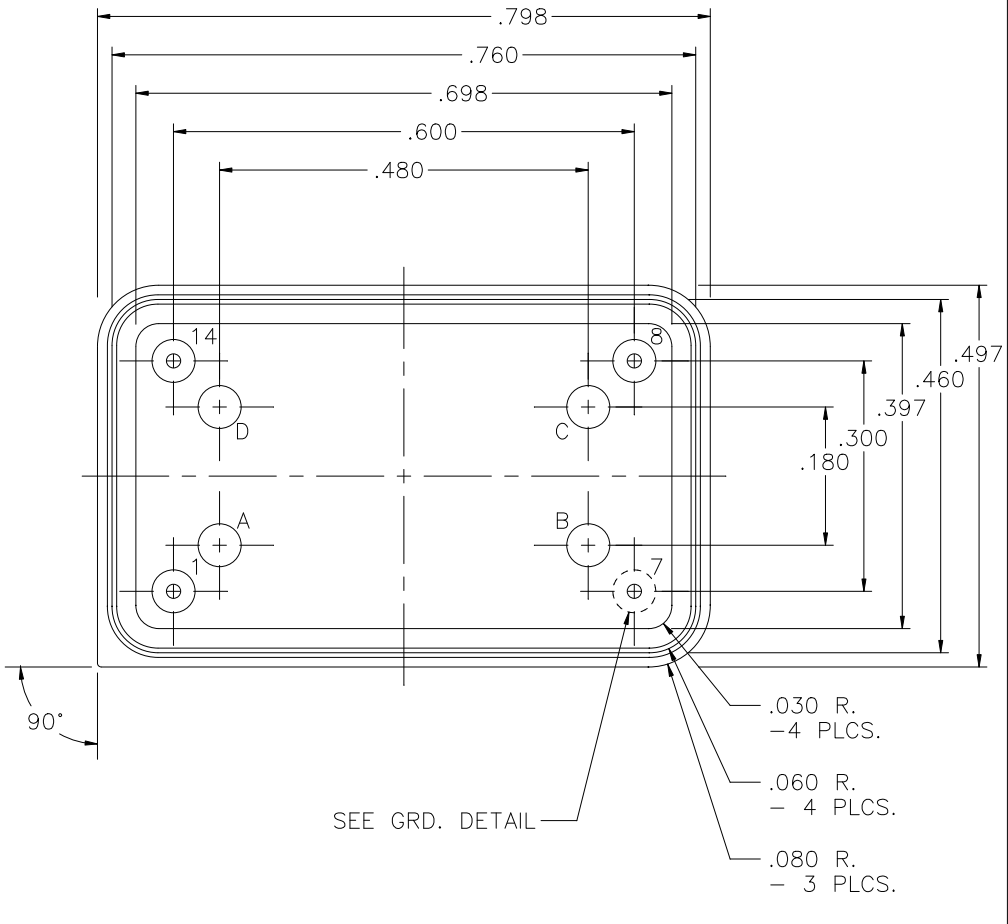

PIN 7 GRD. DETAIL  
SCALE: 8:1

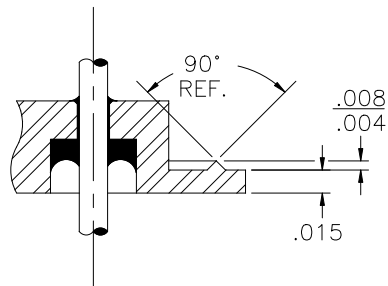

SEE GRD. DETAIL

.030 R.  
- 4 PLCS.

.060 R.  
- 4 PLCS.

.080 R.  
- 3 PLCS.

**MATERIAL:**

- EYELET - 1010 C.R.S. OR EQUAL.
- GLASS - 7052 OR EQUAL.
- LEADS - ASTM F-15 ALLOY, KOVAR.
- BRAZE - BT VTG AG. CU. EUTECTIC.

**PLATING:**

1. OPTION: RoHS COMPLIANT ELECTROLESS NICKEL PLATE OF 100 MICROINCHES MINIMUM FINAL PLATE.
2. OPTION: RoHS COMPLIANT ELECTROLESS NICKEL PLATE OF 100 MICROINCHES MINIMUM FOLLOWED BY A RoHS COMPLIANT LEAD FREE SOLDER COAT, ON LEADS ONLY.
3. OPTION: RoHS COMPLIANT ELECTROLESS NICKEL PLATE OF 100 MICROINCHES MINIMUM FOLLOWED BY A GOLD FLASH OF .99999 PURE 24 KARAT GOLD UP TO A MAX. OF 8 MICROINCHES.

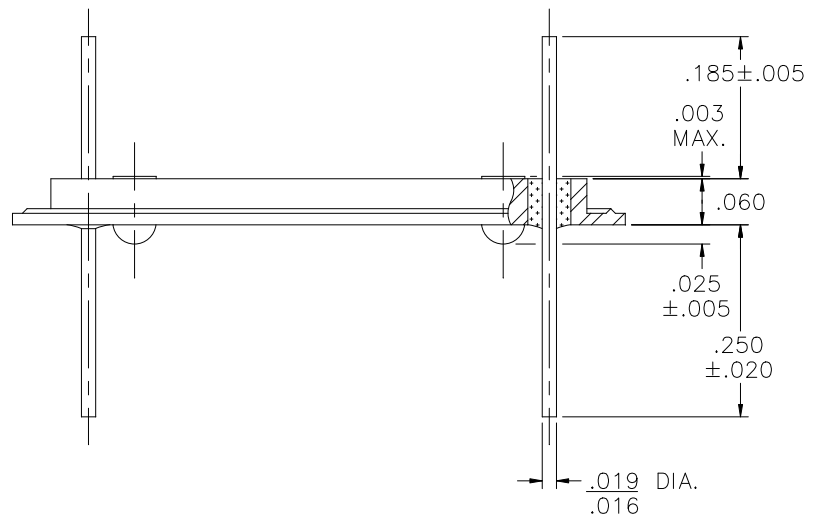

DRAWN BY: E.T.W. 03-15-11		MATERIAL: SEE ABOVE		TOLERANCING PER ANSI Y14.5 .X ±.005 .XXX ±.005 .XX ±.005 ANG ±5° UNLESS OTHERWISE SPECIFIED		 <p>6700 W. 47th TERR. MISSION, KS. 66203 TEL: 913-432-2487 FAX: 913-432-0570</p>
CHECKED BY:	APP. SPECS	SUPERSEDES	NEXT ASSY	SCALE: 4:1	FINISH: UNLESS OTHERWISE SPECIFIED	
APPROVED BY:	TITLE: .498x.798 D.I.P. 4 PIN, P7G, 4 S.O. .025 TALL .180x.480 GRID, .185 PH. .250 LL. FLATTEN POST			FILE:	UB00205C	PAGE 1 of 1