

REV	DESCRIPTION OF REVISION	E.C.N.	BY	APPROVED	DATE
-----	-------------------------	--------	----	----------	------

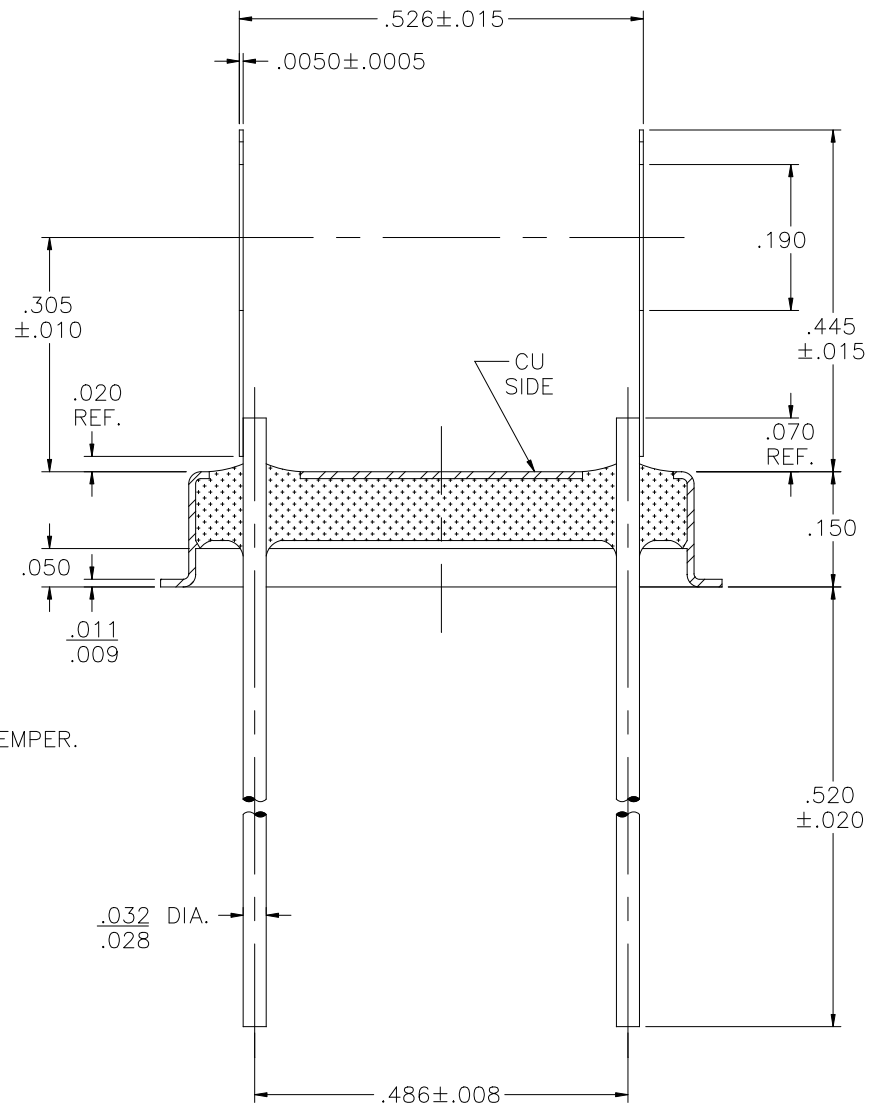
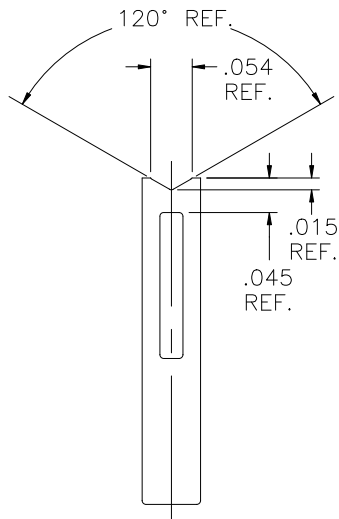
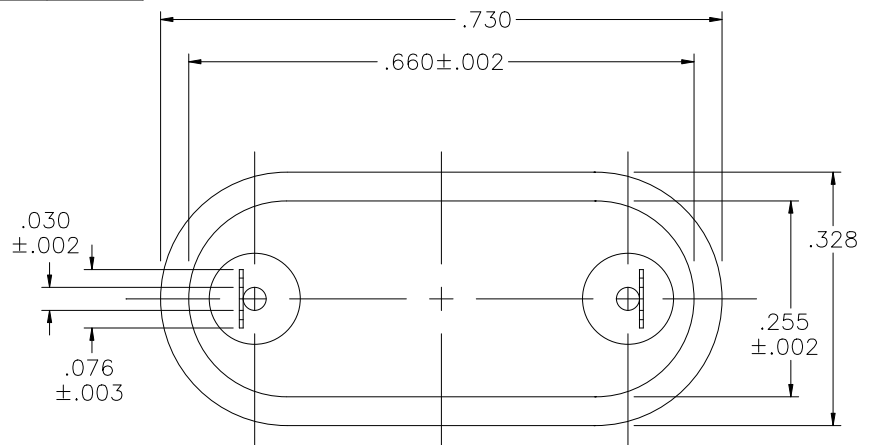

**MATERIAL:**

EYELET - 30/70 COPPER CLAD KOVAR.  
 GLASS - 7052 OR EQUAL.  
 LEADS - ASTM F-15 ALLOY, KOVAR.  
 MOUNT - C770 NICKEL SILVER, 1/2 HARD TEMPER.

**PLATING:**

1. OPTION: RoHS COMPLIANT ELECTROLESS NICKEL PLATE OF 100 TO 200 MICROINCHES FINAL PLATE.
2. OPTION: RoHS COMPLIANT ELECTROLESS NICKEL PLATE OF 100 TO 200 MICROINCHES FOLLOWED BY A RoHS COMPLIANT LEAD FREE SOLDER COAT, ON LEADS ONLY.
3. OPTION: RoHS COMPLIANT ELECTROLESS NICKEL PLATE OF 100 TO 200 MICROINCHES FOLLOWED BY A GOLD FLASH OF .99999 PURE 24 KARAT GOLD UP TO A MAX. OF 8 MICROINCHES.

DRAWN BY: E.T.W. 07-14-09	MATERIAL: SEE ABOVE			TOLERANCING PER ANSI Y14.5 .X ±.005 .XXX ±.005 .XX ±.005 ANG ±5° UNLESS OTHERWISE SPECIFIED		 Legacy Technologies Inc. 6700 W. 47th TERR. MISSION, KS. 66203 TEL: 913-432-2487 FAX: 913-432-0570
	CHECKED BY: E.T.W. 07-14-09	APP. SPECS	SUPERSEDES	NEXT ASSY	SCALE: 4:1	
APPROVED BY: E.T.W. 07-14-09	TITLE: HC-47/U W/ WELD SLOT MOUNT FOR AROUND A .550 DIA. BLANK				PART NUMBER: CW-109-F-WSM043B RoHS	
					FILE: JC00041A	PAGE 1 OF 1