

| REV | DESCRIPTION OF REVISION | E.C.N. | BY | APPROVED | DATE |
|-----|-------------------------|--------|----|----------|------|
|-----|-------------------------|--------|----|----------|------|

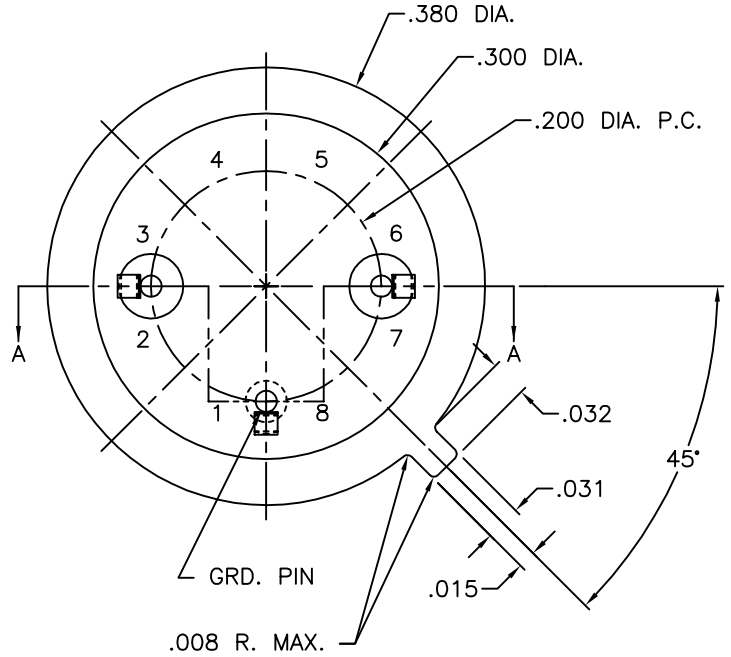



MATERIAL:

EYELET - 30/70 COPPER CLAD KOVAR.
 GLASS - 7052 OR EQUAL, OPAQUE.
 LEADS - ASTM F-15 ALLOY, KOVAR.
 MOUNT - 200 NICKEL, 1/2 HARD.

PLATING:

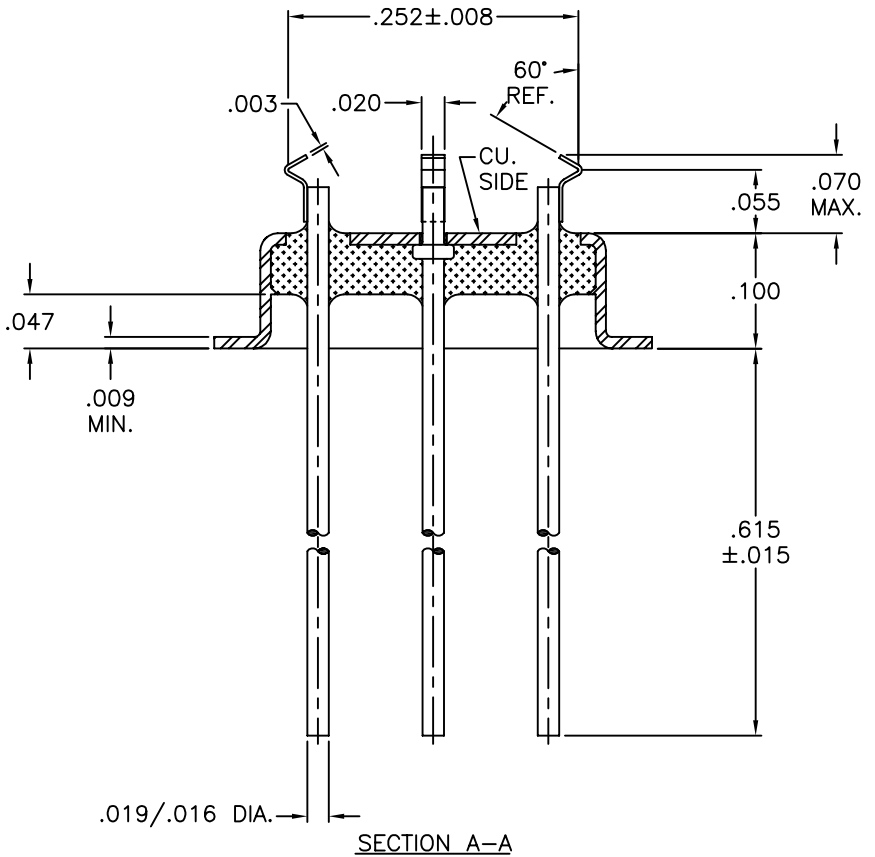
1. ELECTROLESS NICKEL FINAL PLATE OF 100 MICROINCHES MINIMUM.
2. OPTIONAL SOLDER COAT ON LEADS ONLY PER MIL-STD QQ-S-571-D TIN LEAD ALLOY.
3. OPTIONAL GOLD FLASH .99999 PURE 24 KARAT GOLD UP TO A MAX. OF 8 MICROINCHES OVER THE ELECTROLESS NICKEL FINAL PLATE.



| | | | | | | | | |
|---------------------------------|---|------------|------------|----------------------------|--|---|--|----------------------------------|
| DRAWN BY: E.T.W. 01-20-00 | MATERIAL: SEE ABOVE | | | TOLERANCING PER ANSI Y14.5 | |  Legacy Technologies Inc. | 6700 W. 47th TERR. MISSION, KS. 66203 TEL: 913-432-2487 FAX: 913-432-0570 | |
| | CHECKED BY: E.T.W. 01-20-00 | APP. SPECS | SUPERSEDES | NEXT ASSY | .X ± .005 .XXX ± .005 .XX ± .005 ANG ± 5° UNLESS OTHERWISE SPECIFIED | | | PART NUMBER: CW-T05-BR-VN320P |
| APPROVED BY: | TITLE: HC-35/U WIDE FLANGE TYPE W/ V-CLIP | | | | SCALE: 6:1 | FINISH: UNLESS OTHERWISE SPECIFIED <input checked="" type="checkbox"/> | FILE: GA00090 | PAGE 1 of 1 |