

REV	DESCRIPTION OF REVISION	E.C.N.	BY	APPROVED	DATE
A	EYELET DIM. WAS .267 NOW .366		T.J.M.	E.T.W.	02-23-98

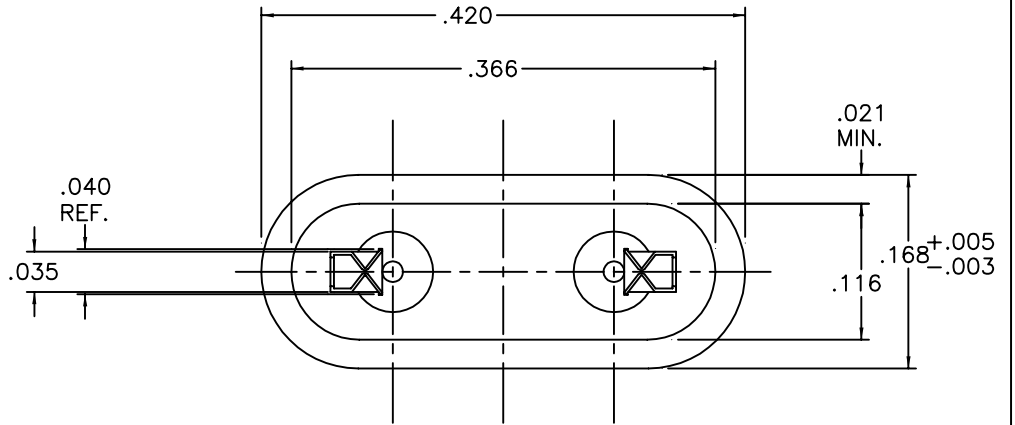

17H B.300	.232
17A B.300	.202
DASH	"A" DIM.

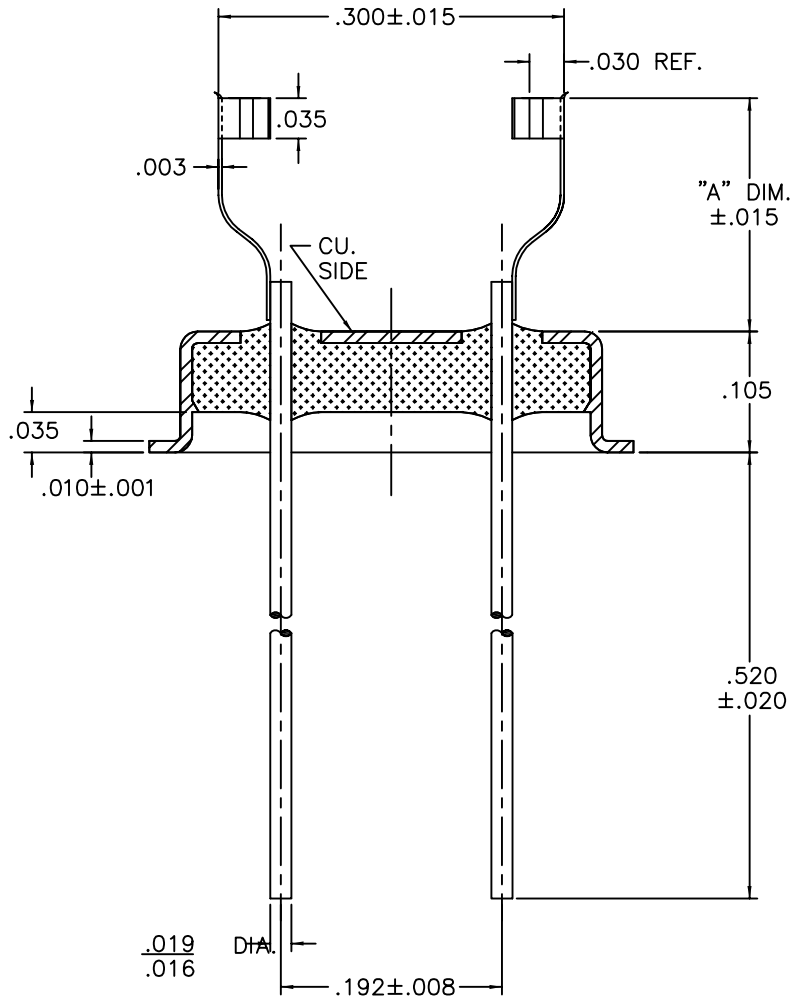

**MATERIAL:**

EYELET - 30/70 COPPER CLAD KOVAR.  
 GLASS - 7052 OR EQUAL.  
 LEADS - ASTM F-15 ALLOY, KOVAR.  
 MOUNT - C770 NICKEL SILVER, FULL HARD.

**PLATING:**

1. ELECTROLESS NICKEL FINAL PLATE OF 100 MICROINCHES MINIMUM.
2. OPTIONAL SOLDER COAT ON LEADS ONLY PER MIL-STD QQ-S-571-D TIN LEAD ALLOY.
3. OPTIONAL GOLD FLASH .99999 PURE 24 KARAT GOLD UP TO A MAX. OF 8 MICROINCHES OVER THE ELECTROLESS NICKEL FINAL PLATE.

DRAWN BY: TINA MOSS 12-11-96	MATERIAL: SEE ABOVE	TOLERANCING PER ANSI Y14.5 .X ± .005 .XXX ± .005 .XX ± .005 ANG ± 5° UNLESS OTHERWISE SPECIFIED		 Legacy Technologies Inc. 6700 W. 47th TERR. MISSION, KS. 66203 TEL: 913-432-2487 FAX: 913-432-0570	
CHECKED BY: E.T.W. 12-11-96	APP. SPECS	SUPERSEDES	NEXT ASSY		PART NUMBER: CW-185- (SEE TABLE) A
APPROVED BY:	TITLE: HC-43/U W/ TAB CLIP			FILE: LA00038B	PAGE 1 of 1