

REV	DESCRIPTION OF REVISION	E.C.N.	BY	APPROVED	DATE
-----	-------------------------	--------	----	----------	------

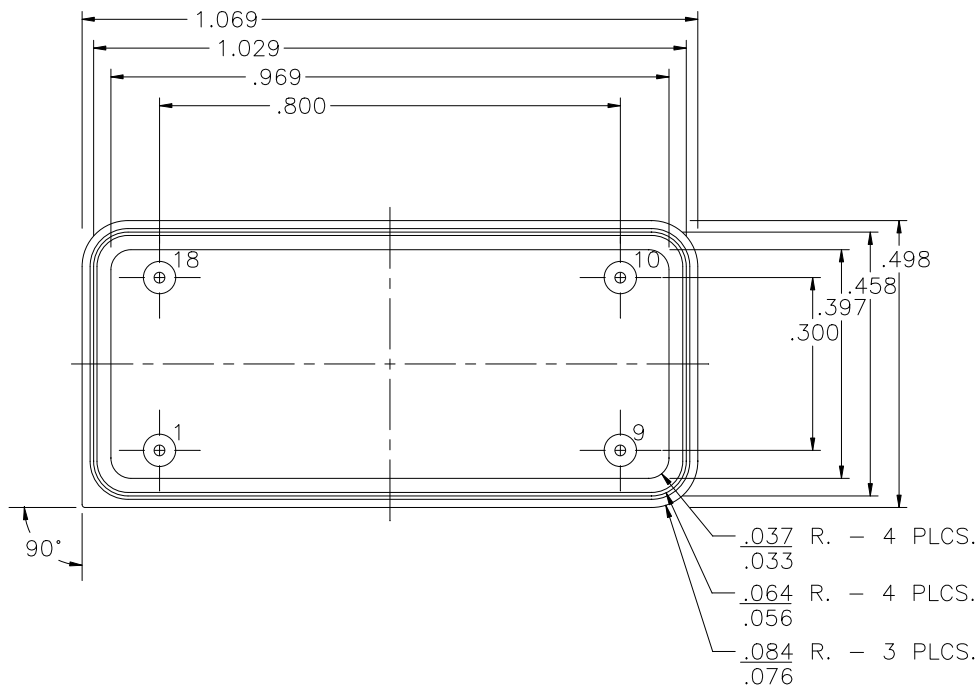

W.R.P. DETAIL
SCALE: 6:1

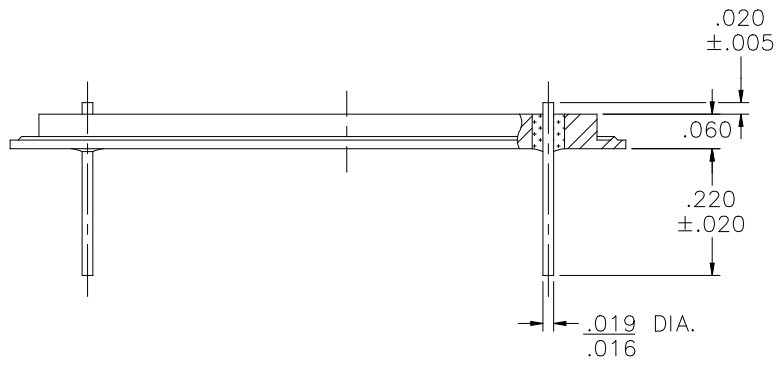
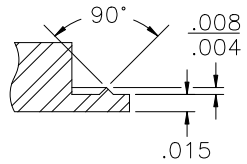

MATERIAL:

- EYELET - 1010 C.R.S. OR EQUAL.
- GLASS - 7052 OR EQUAL.
- LEADS - ASTM F-15 ALLOY, KOVAR.

PLATING:

1. OPTION: RoHS COMPLIANT ELECTROLESS NICKEL PLATE OF 100 MICROINCHES MINIMUM FINAL PLATE.
2. OPTION: RoHS COMPLIANT ELECTROLESS NICKEL PLATE OF 100 MICROINCHES MINIMUM FOLLOWED BY A RoHS COMPLIANT LEAD FREE SOLDER COAT, ON LEADS ONLY.
3. OPTION: RoHS COMPLIANT ELECTROLESS NICKEL PLATE OF 100 MICROINCHES MINIMUM FOLLOWED BY A GOLD FLASH OF .99999 PURE 24 KARAT GOLD UP TO A MAX. OF 8 MICROINCHES.

DRAWN BY: E.T.W. 03-17-11	MATERIAL: SEE ABOVE			TOLERANCING PER ANSI Y14.5 .X ±.005 .XXX ±.005 .XX ±.005 ANG ±5° UNLESS OTHERWISE SPECIFIED		 6700 W. 47th TERR. MISSION, KS. 66203 TEL: 913-432-2487 FAX: 913-432-0570
	CHECKED BY:	APP. SPECS	SUPERSEDES	NEXT ASSY	SCALE: 3:1	
APPROVED BY:	TITLE: .498x.1070 D.I.P. 4 PIN, .020 PH. .220 LL.				PART NUMBER: RR-4981070-E RoHS	
				FILE: UE00003A	PAGE	1 OF 1