

REV	DESCRIPTION OF REVISION	E.C.N.	BY	APPROVED	DATE
A	MOUNT WAS NICKEL		E.T.W.	E.T.W.	06-08-10
B	MOUNT WAS LISTED IS 1324 CLIP		E.T.W.	E.T.W.	08-04-10
C	REMOVED NOTE		E.T.W.	E.T.W.	04-25-13
D	BODY, HOLE & EYELET DIM'S CHANGED PER EMAIL 09-26-14		E.C.	E.T.W.	10-14-14
E	SEAL RING TO TOP EYELET ±.003 & RING TO BOT. OF FLG. .003 MAX.		E.C.	E.T.W.	04-09-15

PATENT NO.:
US6.229.088

PRELIMINARY PRINT
E.T.W. 05-14-10

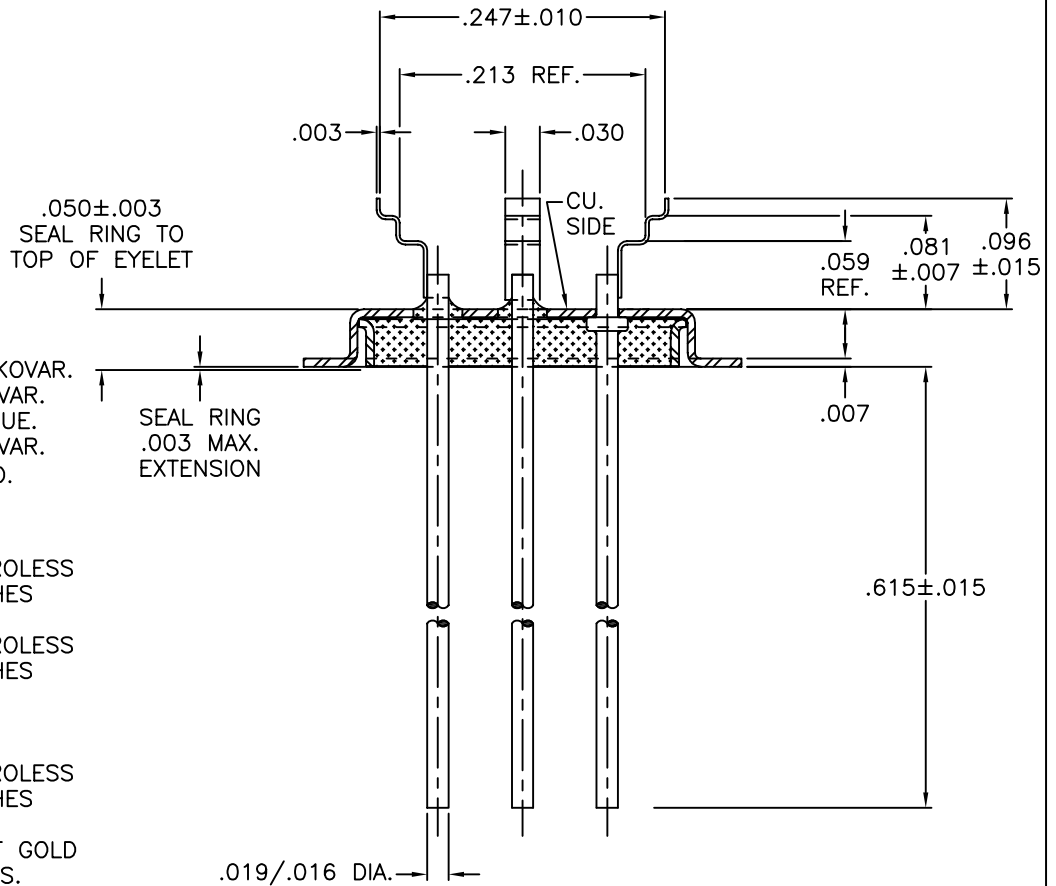
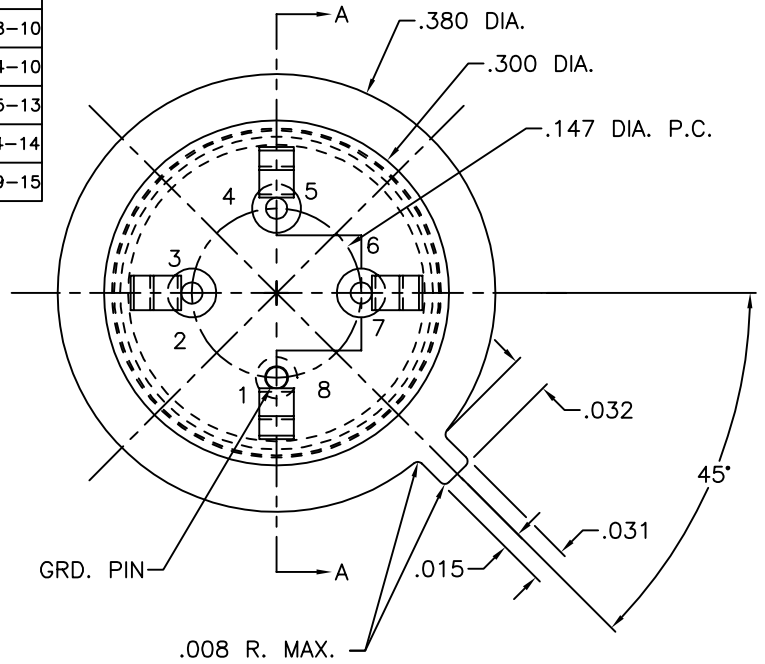

MATERIAL:

- EYELET - 30/70 COPPER CLAD KOVAR.
- SEAL RING- ASTM F-15 ALLOY, KOVAR.
- GLASS - 7052 OR EQUAL, OPAQUE.
- LEADS - ASTM F-15 ALLOY, KOVAR.
- MOUNT - 200 NICKEL, 1/2 HARD.

PLATING:

1. OPTION: RoHS COMPLIANT ELECTROLESS NICKEL PLATE OF 100 MICROINCHES MINIMUM FINAL PLATE.
2. OPTION: RoHS COMPLIANT ELECTROLESS NICKEL PLATE OF 100 MICROINCHES MINIMUM FOLLOWED BY A RoHS COMPLIANT LEAD FREE SOLDER COAT, ON LEADS ONLY.
3. OPTION: RoHS COMPLIANT ELECTROLESS NICKEL PLATE OF 100 MICROINCHES MINIMUM FOLLOWED BY A GOLD FLASH OF .99999 PURE 24 KART GOLD UP TO A MAX. OF 8 MICROINCHES.

SECTION A-A

DRAWN BY: E.T.W. 12-19-05		MATERIAL: SEE ABOVE		TOLERANCING PER ANSI Y14.5 .X ± .005 .XXX ± .005 .XX ± .005 ANG ± 5° UNLESS OTHERWISE SPECIFIED		 Legacy Technologies Inc. 6700 W. 47th TERR. MISSION, KS. 66203 TEL: 913-432-2487 FAX: 913-432-0570		
CHECKED BY: E.T.W. 12-19-05		APP. SPECS	SUPERSEDES	SCALE: 6:1				FINISH: UNLESS OTHERWISE SPECIFIED <input checked="" type="checkbox"/>
APPROVED BY:		TITLE: HC-35/U WIDE FLANGE LOW PROFILE TYPE L.T.I. / KANE P/N: 300-0106-1321-919 REF. W/ .147 DIA. P.C W/ CHAIR MOUNT				PART NUMBER: CWLP-T05-A-CN330C RoHS		E
				FILE: GB00005A		PAGE 1 of 1		