

REV	DESCRIPTION OF REVISION	E.C.N.	BY	APPROVED	DATE
A	P/N: WAS CW-45-015-DB002A B.196 RoHS CHANGE TO CW-45-015A-DB002A B.196 RoHS		E.T.W.	B.D.	05-17-12

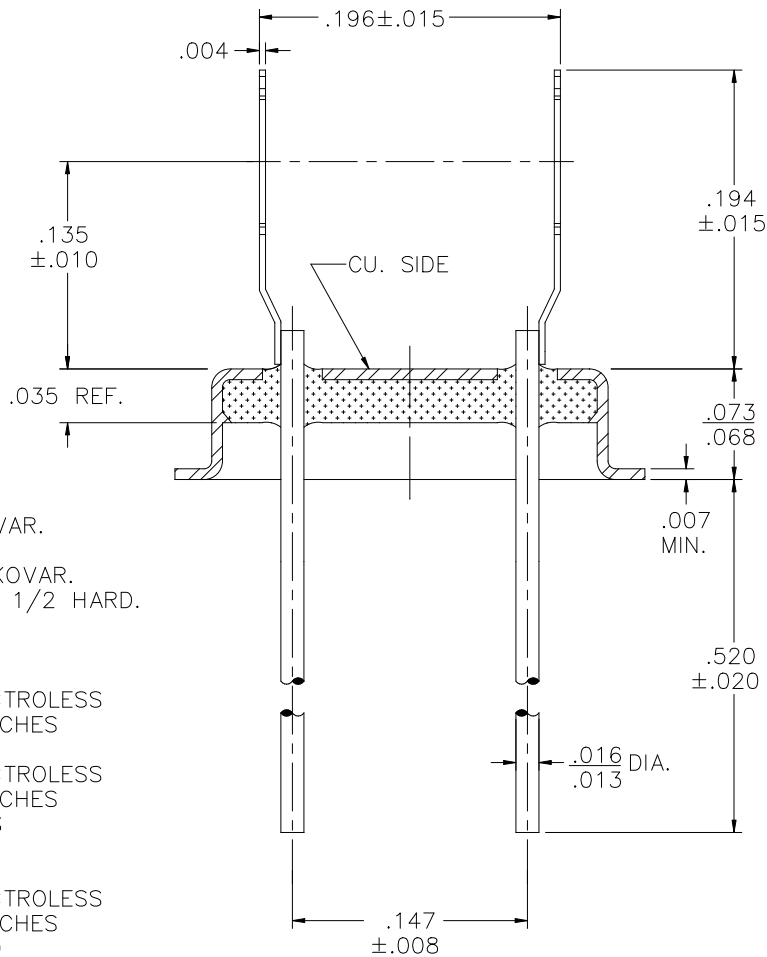
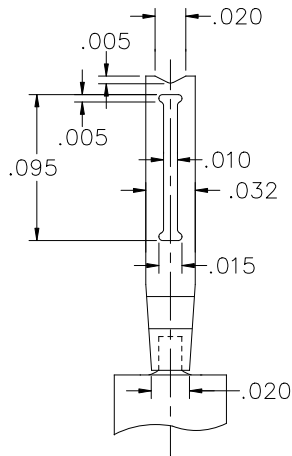
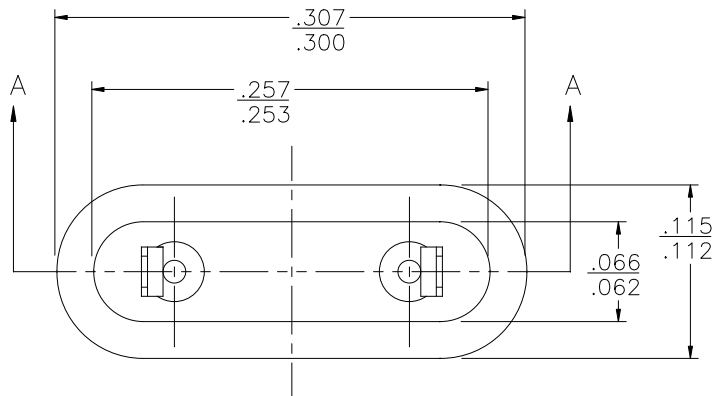

MATERIAL:

EYELET - 30/70 CU. CLAD KOVAR.
 GLASS - 7052 OR EQUAL.
 LEADS - ASTM F-15 ALLOY, KOVAR.
 MOUNT - C770 NICKEL SILVER, 1/2 HARD.

PLATING:

1. OPTION: RoHS COMPLIANT ELECTROLESS NICKEL PLATE OF 100 MICROINCHES MINIMUM FINAL PLATE.
2. OPTION: RoHS COMPLIANT ELECTROLESS NICKEL PLATE OF 100 MICROINCHES MINIMUM FOLLOWED BY A RoHS COMPLIANT LEAD FREE SOLDER COAT, ON LEADS ONLY.
3. OPTION: RoHS COMPLIANT ELECTROLESS NICKEL PLATE OF 100 MICROINCHES MINIMUM FOLLOWED BY A GOLD FLASH OF .99999 PURE 24 KARAT GOLD UP TO A MAX. OF 8 MICROINCHES.

SECTION A-A

DRAWN BY: E.T.W. 02-06-07	MATERIAL: SEE ABOVE			TOLERANCING PER ANSI Y14.5 .X ±.005 .XXX ±.005 .XX ±.005 ANG ±5° UNLESS OTHERWISE SPECIFIED		 6700 W. 47th TERR. MISSION, KS. 66203 TEL: 913-432-2487 FAX: 913-432-0570
CHECKED BY:	APP. SPECS	SUPERSEDES	NEXT ASSY	SCALE: N.T.S.	FINISH: UNLESS OTHERWISE SPECIFIED	
APPROVED BY:	TITLE: HC-45/U W/ DOG BONE MOUNT				PART NUMBER: CW-45-015A-DB002A B.196 RoHS	A
					FILE: MB00013C	PAGE 1 OF 1