

REV	DESCRIPTION OF REVISION	E.C.N.	BY	APPROVED	DATE
-----	-------------------------	--------	----	----------	------

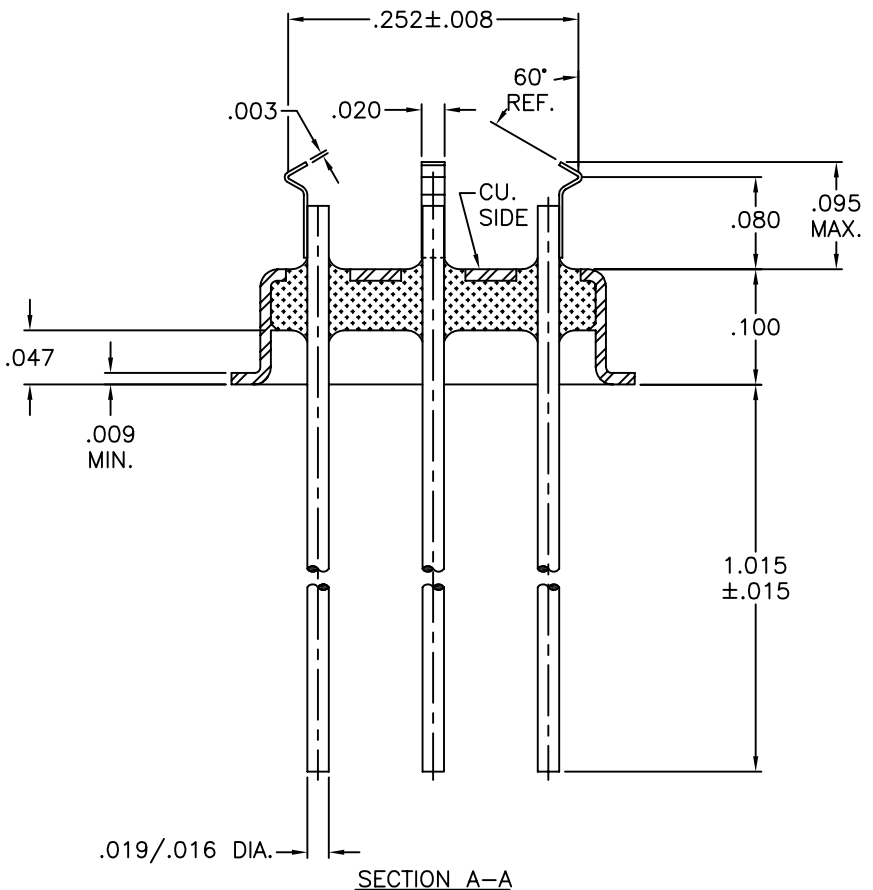
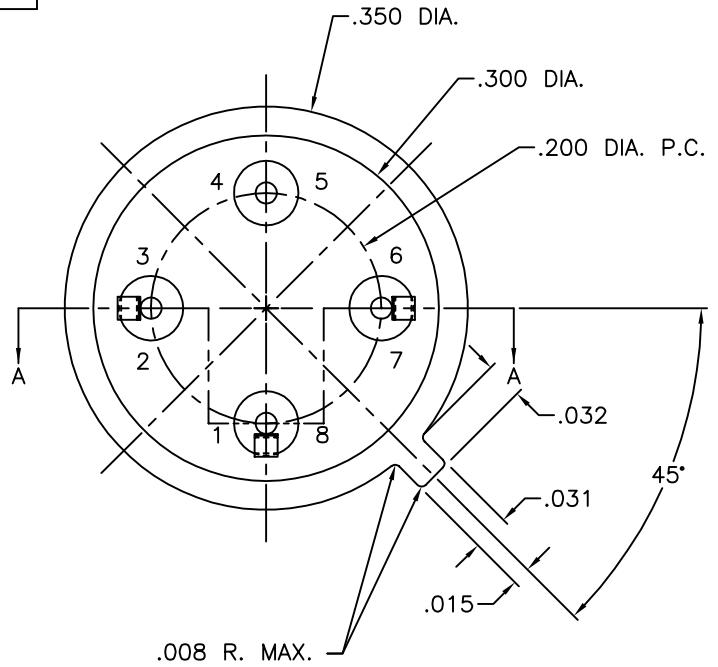

**MATERIAL:**

- EYELET - 30/70 COPPER CLAD KOVAR.
- GLASS - 7052 OR EQUAL, CLEAR.
- LEADS - ASTM F-15 ALLOY, KOVAR.
- MOUNT - 200 NICKEL, 1/2 HARD.

**PLATING:**

1. ELECTROLESS NICKEL FINAL PLATE OF 100 MICROINCHES MINIMUM.
2. OPTIONAL SOLDER COAT ON LEADS ONLY PER MIL-STD QQ-S-571-D TIN LEAD ALLOY.
3. OPTIONAL GOLD FLASH .99999 PURE 24 KARAT GOLD UP TO A MAX. OF 8 MICROINCHES OVER THE ELECTROLESS NICKEL FINAL PLATE.

DRAWN BY: TINA MOSS 12-10-96	MATERIAL: SEE ABOVE			TOLERANCING PER ANSI Y14.5 .X ± .005 .XXX ± .005 .XX ± .005 ANG ± 5° UNLESS OTHERWISE SPECIFIED		 6700 W. 47th TERR. MISSION, KS. 66203 TEL: 913-432-2487 FAX: 913-432-0570
	CHECKED BY: E.T.W. 12-10-96	APP. SPECS	SUPERSEDES	NEXT ASSY	SCALE: 6:1	
APPROVED BY:	TITLE: HC-35/U NARROW FLANGE TYPE W/ V-CLIP 3 PLCS.				PART NUMBER: CW-T05-DL-VN320L	
				FILE: GA00053A	PAGE	1 of 1