

REV	DESCRIPTION OF REVISION	E.C.N.	BY	APPROVED	DATE
A	CORRECTED P/N AND MAT'L WAS CW-185-17C SS W/IS B. 55° & STAINLESS STEEL.		E.T.W.	E.T.W.	11-19-04

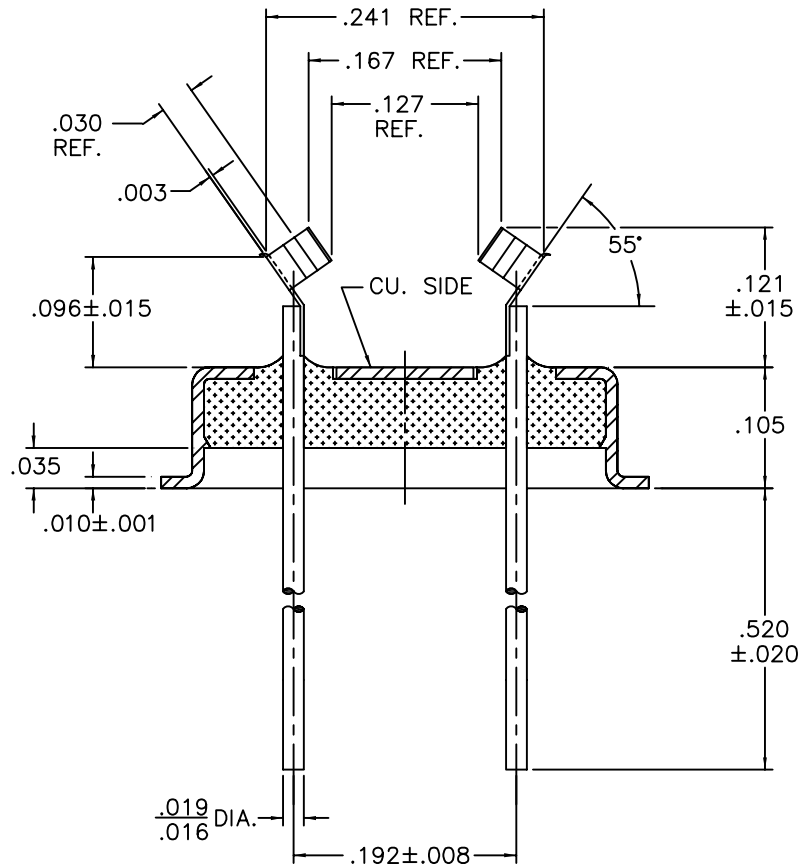
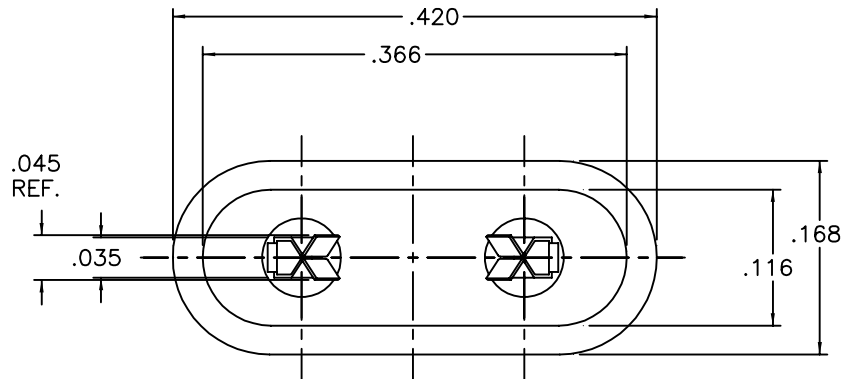

MATERIAL:

EYELET - 30/70 COPPER CLAD KOVAR.
 GLASS - 7052 OR EQUAL.
 LEADS - ASTM F-15 ALLOY, KOVAR.
 MOUNT - C770 NICKEL SILVER, FULL HARD.

PLATING:

1. ELECTROLESS NICKEL FINAL PLATE OF 100 MICROINCHES MINIMUM.
2. OPTIONAL SOLDER COAT ON LEADS ONLY PER MIL-STD QQ-S-571-D TIN LEAD ALLOY.
3. OPTIONAL GOLD FLASH .99999 PURE 24 KARAT GOLD UP TO A MAX. OF 8 MICROINCHES OVER THE ELECTROLESS NICKEL FINAL PLATE.

DRAWN BY: E.T.W. 05-10-99	MATERIAL: SEE ABOVE			TOLERANCING PER ANSI Y14.5 .X ± .005 .XXX ± .005 .XX ± .005 ANG ± 5° UNLESS OTHERWISE SPECIFIED		 Legacy Technologies Inc. 6700 W. 47th TERR. MISSION, KS. 66203 TEL: 913-432-2487 FAX: 913-432-0570	PART NUMBER: CW-185-17C W/IS B. 55°	A
	CHECKED BY: E.T.W. 05-10-99	APP. SPECS	SUPERSEDES	NEXT ASSY	SCALE: N.T.S.			
APPROVED BY:	TITLE: HC-43/U W/ TAB CLIP BENT AT A 55° ANGLE				FILE: LA00026B	PAGE	1 of 1	