

REV	DESCRIPTION OF REVISION	E.C.N.	BY	APPROVED	DATE
-----	-------------------------	--------	----	----------	------

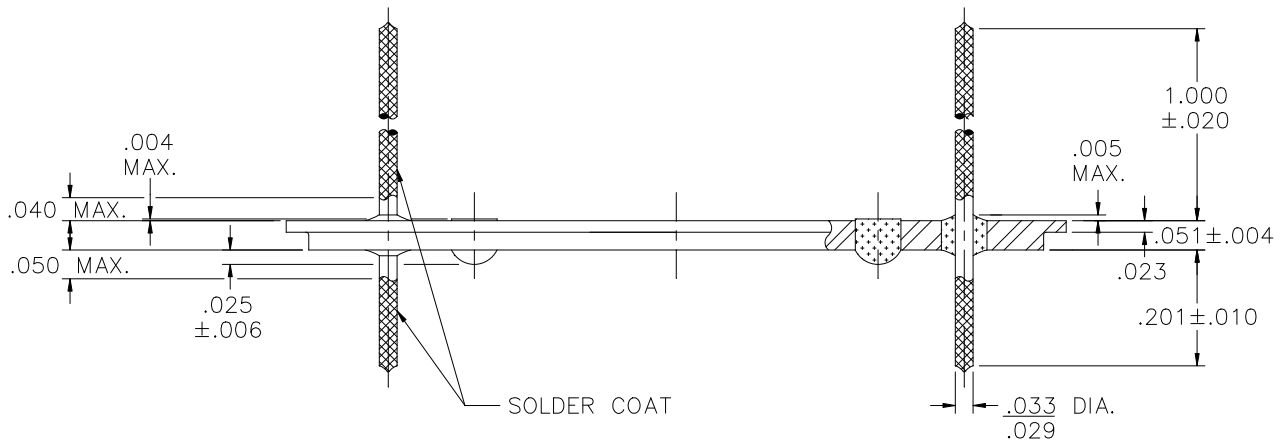
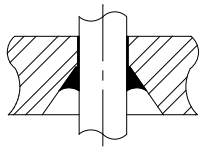
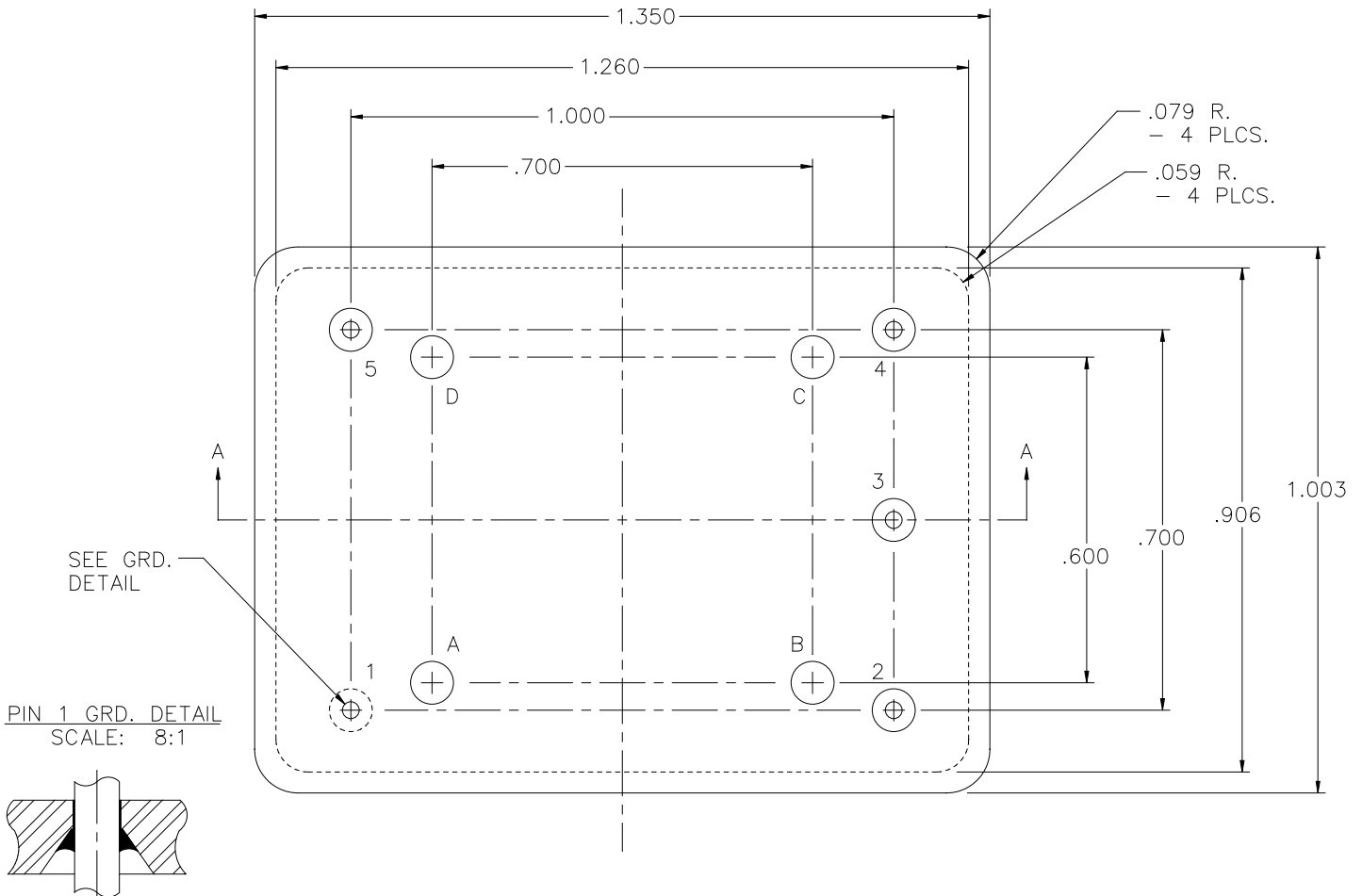

MATERIAL:

EYELET- 1010 C.R.S.
 GLASS - 9013 OR EQUAL.
 LEADS - ASTM F-30, 52 ALLOY.
 BRAZE - BT VTG AG. CU. EUTECTIC.

PLATING:

1. ELECTROLESS NICKEL FINAL PLATE OF 100 MICRONS MINIMUM.
2. SOLDER COAT ON POST AND LEADS PER MIL-STD QQ-S-571-D TIN LEAD ALLOY.

DRAWN BY: E.T.W. 02-14-02	MATERIAL: SEE ABOVE			TOLERANCING PER ANSI Y14.5 .X ±.005 .XXX ±.005 .XX ±.005 ANG ±5° UNLESS OTHERWISE SPECIFIED		 Legacy Technologies Inc. 6700 W. 47th TERR. MISSION, KS. 66203 TEL: 913-432-2487 FAX: 913-432-0570
	CHECKED BY:	APP. SPECS	SUPERSEDES	NEXT ASSY	SCALE: N.T.S.	
APPROVED BY:	TITLE: 1.003 x 1.350 EUROPACK HEADER				PART NUMBER: DC-1003-1350-M PT/LT	
				FILE:	WA00042A	PAGE 1 OF 1