

REV	DESCRIPTION OF REVISION	E.C.N.	BY	APPROVED	DATE
-----	-------------------------	--------	----	----------	------

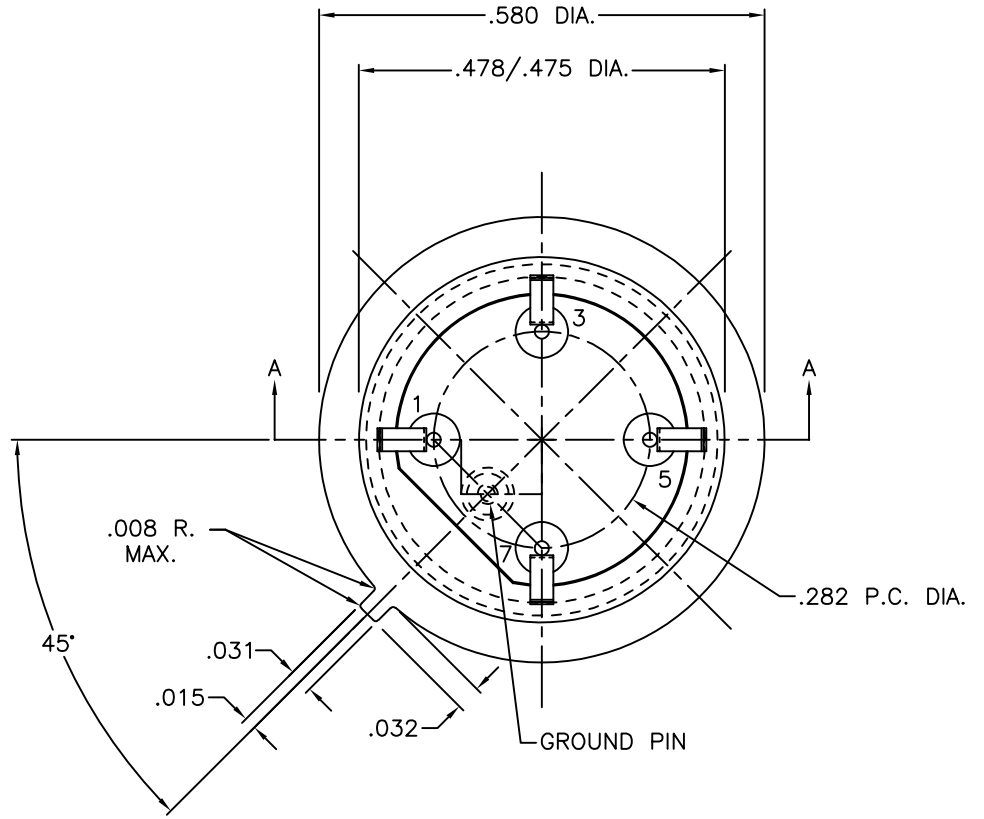

NOTE:
POST HEIGHT IS SPECIFIED OFF THE HIGHEST POINT ON THE POST SIDE.

MATERIAL:
 EYELET - 1010 C.R.S. OR EQUAL.
 FLANGE - 30/70 COPPER CLAD KOVAR.
 GLASS - 7052 OR EQUAL, OPAQUE.
 LEADS - ASTM F-15 ALLOY, KOVAR.
 BRAZE - AG. CU. INDIUM ALLOY.
 MOUNT - 200 NICKEL, 1/2 HARD.

PLATING:
 1. OPTION: RoHS COMPLIANT ELECTROLESS NICKEL PLATE OF 100 MICROINCHES MINIMUM FINAL PLATE.
 2. OPTION: RoHS COMPLIANT ELECTROLESS NICKEL PLATE OF 100 MICROINCHES MINIMUM FOLLOWED BY A RoHS COMPLIANT LEAD FREE SOLDER COAT, ON LEADS ONLY.
 3. OPTION: RoHS COMPLIANT ELECTROLESS NICKEL PLATE OF 100 MICROINCHES MINIMUM FOLLOWED BY A GOLD FLASH OF .99999 PURE 24 KART GOLD UP TO A MAX. OF 8 MICROINCHES.

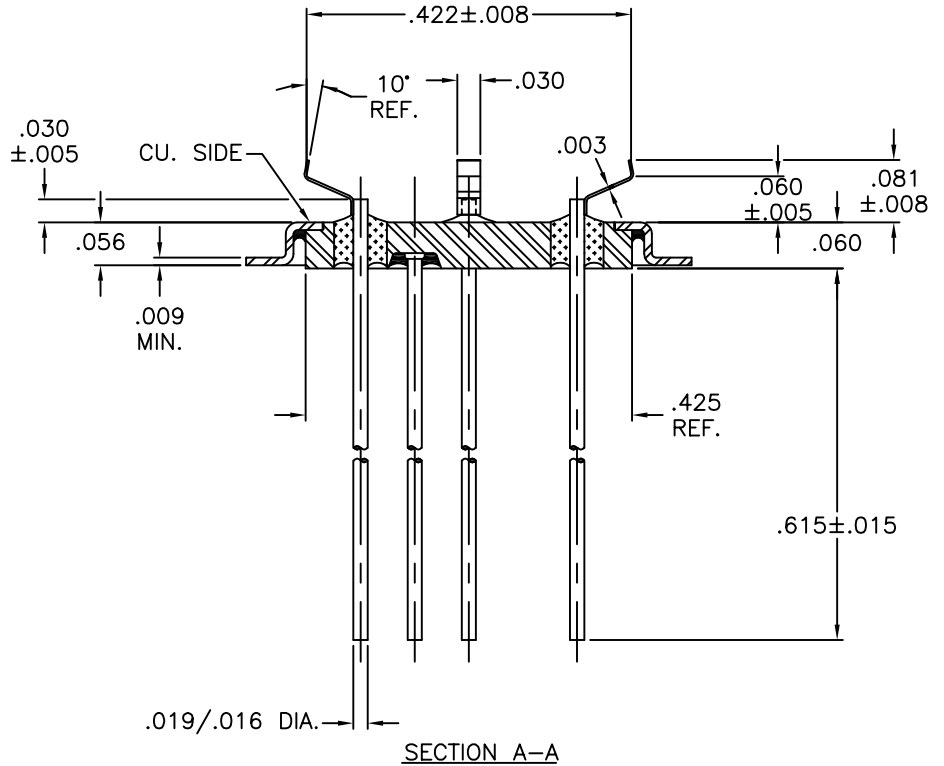

DRAWN BY: E.T.W. 09-08-11	MATERIAL: SEE ABOVE			TOLERANCING PER ANSI Y14.5 .X ± .005 .XXX ± .005 .XX ± .005 ANG ± 5° UNLESS OTHERWISE SPECIFIED		 Legacy Technologies Inc. 6700 W. 47th TERR. MISSION, KS. 66203 TEL: 913-432-2487 FAX: 913-432-0570
	CHECKED BY: D.P. 09-08-11	APP. SPECS	SUPERSEDES	NEXT ASSY	SCALE: 4:1	
APPROVED BY: A.B. 09-08-11	TITLE: HC-37/U WIDE REF. FLANGE LOW PROFILE				PART NUMBER: LP-T08-017B-VN330BM RoHS	
				FILE: HM00005A	PAGE 1 of 1	