

| REV | DESCRIPTION OF REVISION | E.C.N. | BY | APPROVED | DATE |
|-----|-------------------------|--------|----|----------|------|
|-----|-------------------------|--------|----|----------|------|

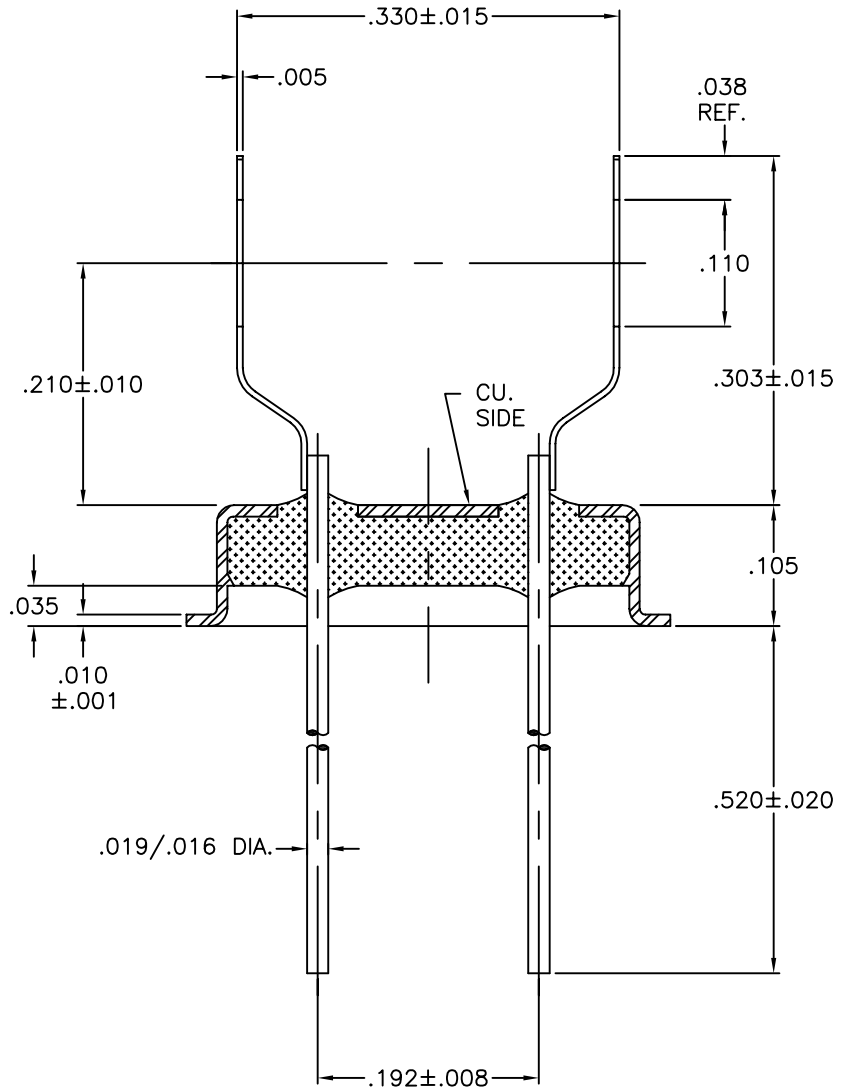
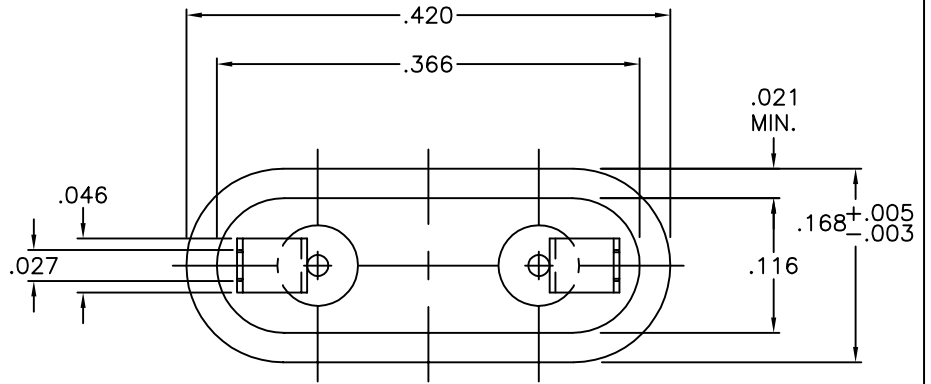

MATERIAL:

EYELET - 30/70 COPPER CLAD KOVAR.
 GLASS - 7052 OR EQUAL.
 LEADS - ASTM F-15 ALLOY, KOVAR.
 MOUNT - STAINLESS STEEL.

PLATING:

1. OPTION: RoHS COMPLIANT ELECTROLESS NICKEL PLATE OF 100 MICROINCHES MINIMUM FINAL PLATE.
2. OPTION: RoHS COMPLIANT ELECTROLESS NICKEL PLATE OF 100 MICROINCHES MINIMUM FOLLOWED BY A RoHS COMPLIANT LEAD FREE SOLDER COAT, ON LEADS ONLY.
3. OPTION: RoHS COMPLIANT ELECTROLESS NICKEL PLATE OF 100 MICROINCHES MINIMUM FOLLOWED BY A GOLD FLASH OF .99999 PURE 24 KART GOLD UP TO A MAX. OF 8 MICROINCHES.

| | | | | | | |
|---------------------------------|---|------------|------------|--|---|---|
| DRAWN BY: E.T.W. 03-01-07 | MATERIAL: SEE ABOVE | | | TOLERANCING PER ANSI Y14.5 .X ± .005 .XXX ± .005 .XX ± .005 ANG ± 5° UNLESS OTHERWISE SPECIFIED | |  Legacy Technologies Inc. 6700 W. 47th TERR. MISSION, KS. 66203 TEL: 913-432-2487 FAX: 913-432-0570 |
| | CHECKED BY: E.T.W. 03-01-07 | APP. SPECS | SUPERSEDES | NEXT ASSY | SCALE: 6:1 | |
| APPROVED BY: | TITLE: HC-43/U W/ SLOT MOUNT FOR AROUND .340 DIA. BLANK | | | | PART NUMBER: CW-185-WSM-JLA B.330 RoHS | FILE: LE00012A |
| | | | | | | PAGE 1 of 1 |