

REV	DESCRIPTION OF REVISION	E.C.N.	BY	APPROVED	DATE
A	CORRECTED SLOT WIDTH WAS .010 NOW .011		E.T.W.	E.T.W.	01-19-01

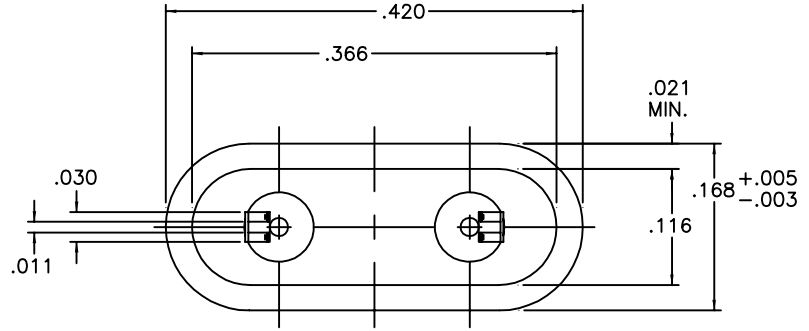

HM05-6 B.260	.130
HM05-5 B.260	.179
HM05-4 B.260	.201
HM05-3 B.260	.211
HM05-2 B.260	.166
HM05-1 B.260	.141
DASH	"A" DIM.

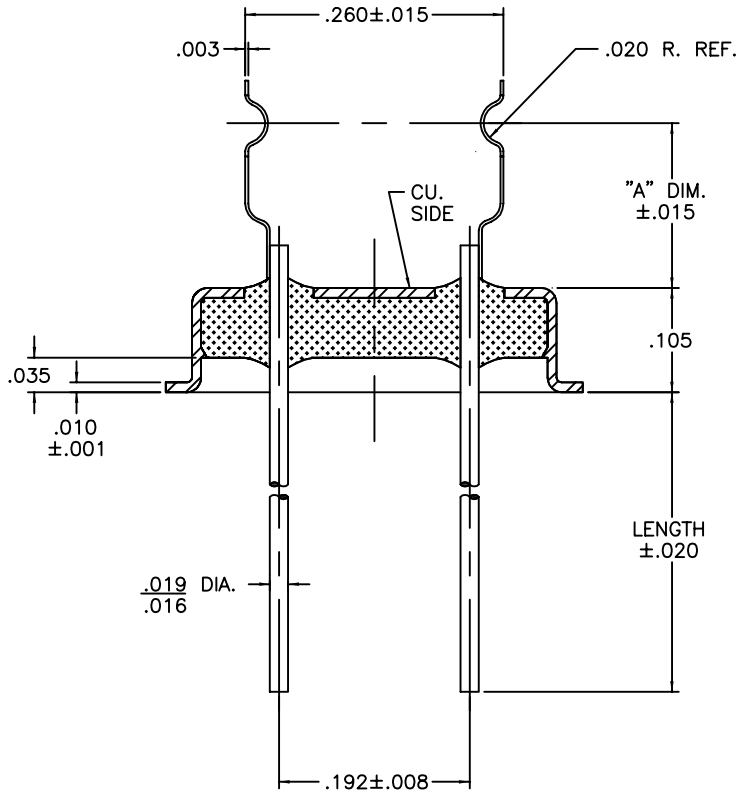

**MATERIAL:**

EYELET - 30/70 COPPER CLAD KOVAR.  
 GLASS - 7052 OR EQUAL.  
 LEADS - ASTM F-15 ALLOY, KOVAR.  
 MOUNT - C770 NICKEL SILVER, FULL HARD.

**PLATING:**

1. ELECTROLESS NICKEL FINAL PLATE OF 100 MICROINCHES MINIMUM.
2. OPTIONAL SOLDER COAT ON LEADS ONLY PER MIL-STD QQ-S-571-D TIN LEAD ALLOY.
3. OPTIONAL GOLD FLASH .99999 PURE 24 KARAT GOLD UP TO A MAX. OF 8 MICROINCHES OVER THE ELECTROLESS NICKEL FINAL PLATE.

CW-186-	.620
CW-185-	.520
PART NO.	LENGTH

DRAWN BY: E.T.W. 11-03-00	MATERIAL: SEE ABOVE	TOLERANCING PER ANSI Y14.5 .X ± .005 .XXX ± .005 .XX ± .005 ANG ± 5° UNLESS OTHERWISE SPECIFIED	<p>6700 W. 47th TERR. MISSION, KS. 66203 TEL: 913-432-2487 FAX: 913-432-0570</p>
CHECKED BY: E.T.W. 11-03-00	APP. SPECS	SCALE: 6:1	
APPROVED BY:	TITLE: HC-43/U TYPE W/ HOOK MOUNT FOR .260 DIA. BLANK	FINISH: UNLESS OTHERWISE SPECIFIED <input checked="" type="checkbox"/>	PART NUMBER: SEE TABLE
		FILE: LA00032B	PAGE 1 of 1