

REV	DESCRIPTION OF REVISION	E.C.N.	BY	APPROVED	DATE
-----	-------------------------	--------	----	----------	------

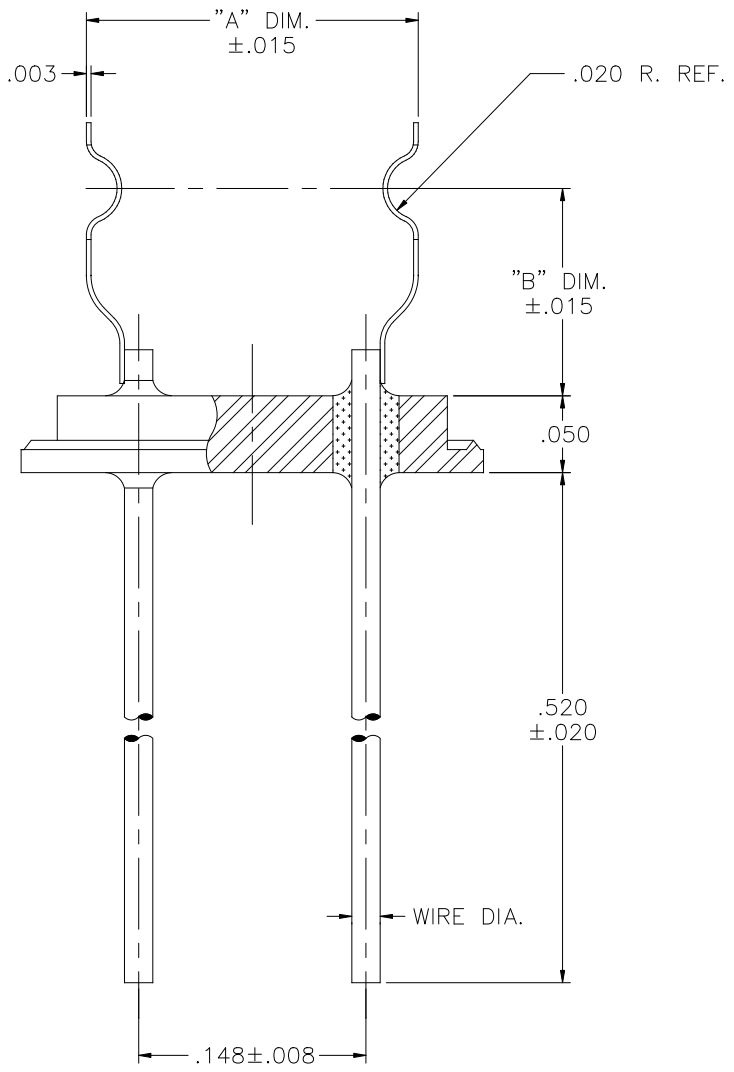
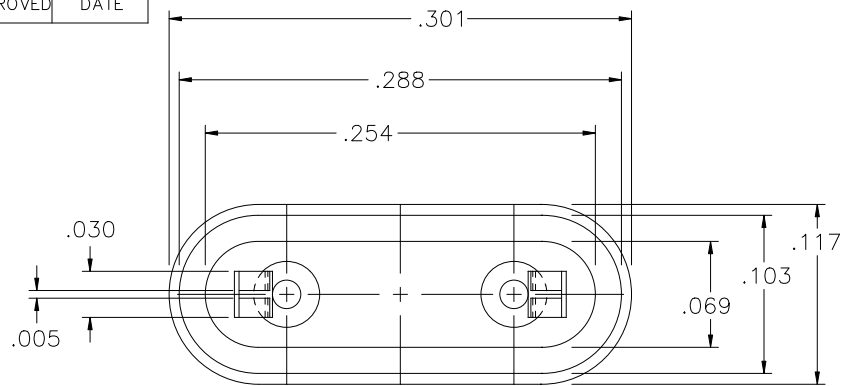

HM09-6 B.197 RoHS	.197	.135
HM09-1 B.216 RoHS	.216	.135
DASH	"A" DIM.	"B" DIM.

**MATERIAL:**

- EYELET - 1010 C.R.S. OR EQUAL.
- GLASS - 9013 OR EQUAL.
- LEADS - ASTM F-30, 52 ALLOY.
- MOUNT - C770 NICKEL SILVER, FULL HARD.

**PLATING:**

1. OPTION: RoHS COMPLIANT ELECTROLESS NICKEL PLATE OF 100 MICROINCHES MINIMUM FINAL PLATE.
2. OPTION: RoHS COMPLIANT ELECTROLESS NICKEL PLATE OF 100 MICROINCHES MINIMUM FOLLOWED BY A RoHS COMPLIANT LEAD FREE SOLDER COAT, ON LEADS ONLY.
3. OPTION: RoHS COMPLIANT ELECTROLESS NICKEL PLATE OF 100 MICROINCHES MINIMUM FOLLOWED BY A GOLD FLASH OF .99999 PURE 24 KARAT GOLD UP TO A MAX. OF 8 MICROINCHES.

RR-45-015-	.016/.013
RR-45-	.019/.016
PART NO.	WIRE DIA.

DRAWN BY: E.T.W. 04-11-06	MATERIAL: SEE ABOVE			TOLERANCING PER ANSI Y14.5 .X ±.005 .XXX ±.005 .XX ±.005 ANG ±5° UNLESS OTHERWISE SPECIFIED		 LEGACY TECHNOLOGIES INC. 1851 MERRIAM LANE KANSAS CITY, KS. 66106 TEL: 913-432-2487 FAX: 913-432-0570
	CHECKED BY:	APP. SPECS	SUPERSEDES	NEXT ASSY	SCALE: 8:1	
APPROVED BY:	TITLE: HC-45/U RESISTACE WELD W/ HOOK MOUNT				PART NUMBER: SEE TABLE	
				FILE: VA00011G	PAGE	1 of 1