

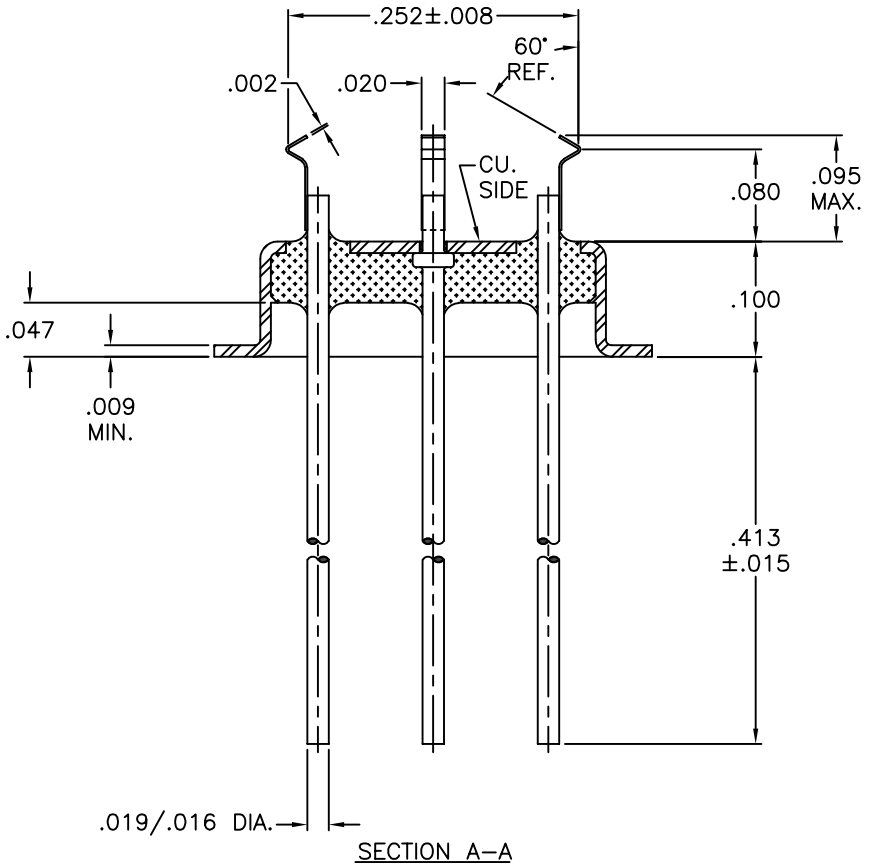

REV	DESCRIPTION OF REVISION	E.C.N.	BY	APPROVED	DATE
A	CLIP MAT'L WAS NICKEL 200/201 AS ROLLED TEMPER.		E.T.W.	E.T.W.	10-03-01

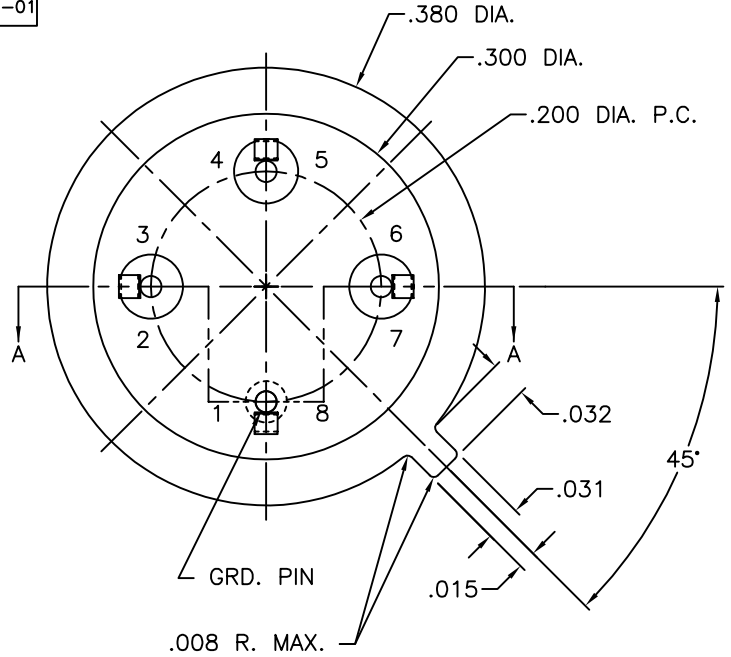

MATERIAL:
 EYELET - 30/70 COPPER CLAD KOVAR.
 GLASS - 7052 OR EQUAL, CLEAR.
 LEADS - ASTM F-15 ALLOY, KOVAR.
 MOUNT - 200 NICKEL, 1/2 HARD.

PLATING:

1. ELECTROLESS NICKEL FINAL PLATE OF 100 MICROINCHES MINIMUM.
2. OPTIONAL SOLDER COAT ON LEADS ONLY PER MIL-STD QQ-S-571-D TIN LEAD ALLOY.
3. OPTIONAL GOLD FLASH .99999 PURE 24 KARAT GOLD UP TO A MAX. OF 8 MICROINCHES OVER THE ELECTROLESS NICKEL FINAL PLATE.

DRAWN BY: E.T.W. 01-11-00	MATERIAL: SEE ABOVE			TOLERANCING PER ANSI Y14.5 .X ± .005 .XXX ± .005 .XX ± .005 ANG ± 5° UNLESS OTHERWISE SPECIFIED		 Legacy Technologies Inc. 6700 W. 47th TERR. MISSION, KS. 66203 TEL: 913-432-2487 FAX: 913-432-0570
	CHECKED BY: E.T.W. 01-11-00	APP. SPECS	SUPERSEDES	NEXT ASSY	SCALE: 6:1	
APPROVED BY:	TITLE: HC-35/U WIDE FLANGE TYPE W/ V-CLIP				PART NUMBER: CW-T05-GY-VN220N	A
					FILE: GA00085A	PAGE 1 of 1