

| REV | DESCRIPTION OF REVISION | E.C.N. | BY | APPROVED | DATE |
|-----|---|--------|------|----------|---------|
| A | CLASS STOP WAS .043 REF. EYELET REV. B ON 10-07-10 | | E.C. | E.T.W. | 3-06-15 |

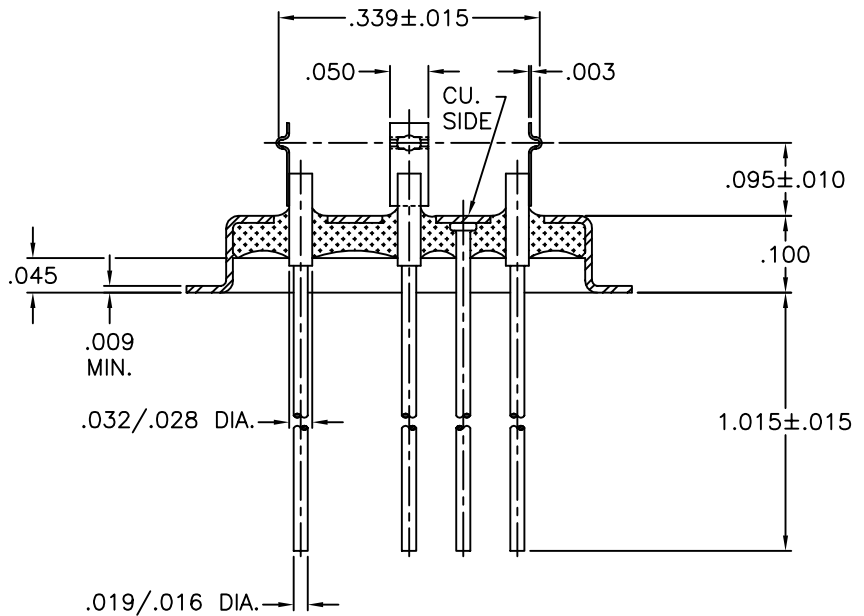
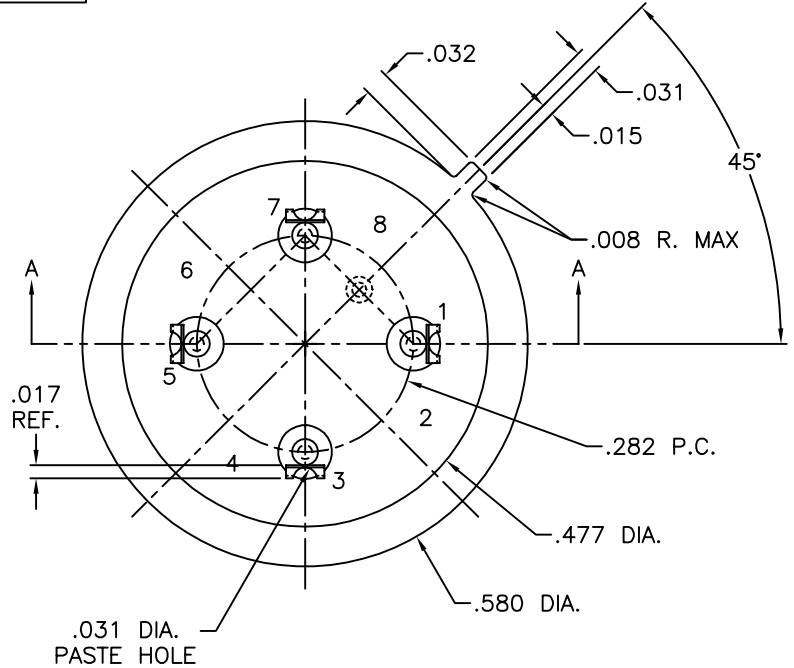

SECTION A-A

MATERIAL:

EYELET - 30/70 COPPER CLAD KOVAR.
GLASS - 7052 OR EQUAL, OPAQUE.
LEADS - ASTM F-15 ALLOY, KOVAR.
MOUNT - 200 NICKEL, 1/4 HARD.

PLATING:

1. OPTION: RoHS COMPLIANT ELECTROLESS NICKEL PLATE OF 100 MICROINCHES MINIMUM FINAL PLATE.
2. OPTION: RoHS COMPLIANT ELECTROLESS NICKEL PLATE OF 100 MICROINCHES MINIMUM FOLLOWED BY A RoHS COMPLIANT LEAD FREE SOLDER COAT, ON LEADS ONLY.
3. OPTION: RoHS COMPLIANT ELECTROLESS NICKEL PLATE OF 100 MICROINCHES MINIMUM FOLLOWED BY A GOLD FLASH OF .99999 PURE 24 KART GOLD UP TO A MAX. OF 8 MICROINCHES.

| | | | | | | |
|---------------------------------|---|------------|------------|--|--|---|
| DRAWN BY: E.T.W. 06-11-10 | MATERIAL: SEE ABOVE | | | TOLERANCING PER ANSI Y14.5 .X ± .005 .XXX ± .005 .XX ± .005 ANG ± 5° UNLESS OTHERWISE SPECIFIED | |  Legacy Technologies Inc. 6700 W. 47th TERR. MISSION, KS. 66203 TEL: 913-432-2487 FAX: 913-432-0570 |
| | CHECKED BY: E.T.W. 06-11-10 | APP. SPECS | SUPERSEDES | NEXT ASSY | SCALE: 4:1 | |
| APPROVED BY: | TITLE: HC-37/U (COLD WELD TO-8) W/ TN-704 CLIPS | | | | PART NUMBER: CW-T08-BW-C-TN350BH RoHS | A |
| | | | | | FILE: HC00013A | PAGE 1 of 1 |