

REV	DESCRIPTION OF REVISION	E.C.N.	BY	APPROVED	DATE
-----	-------------------------	--------	----	----------	------

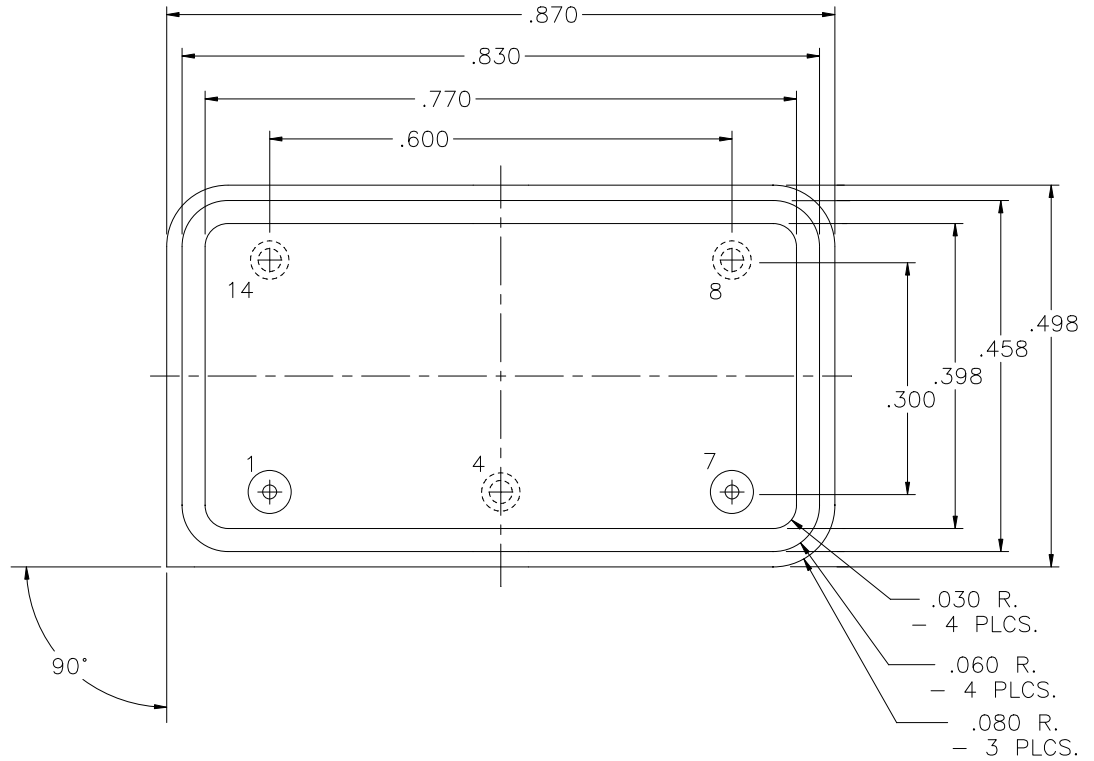

W.R.P. DETAIL
SCALE: 8:1

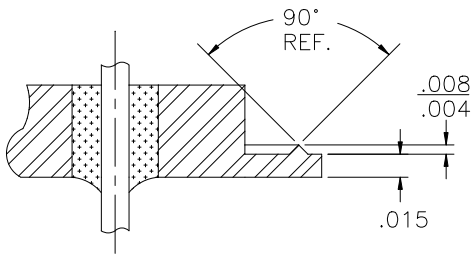



MATERIAL:

EYELET- 1010 C.R.S. OR EQUAL.
GLASS - 7052 OR EQUAL.
LEADS - ASTM F-15 ALLOY, KOVAR.
BRAZE - BT VTG AG. CU. EUTECTIC.

PLATING:

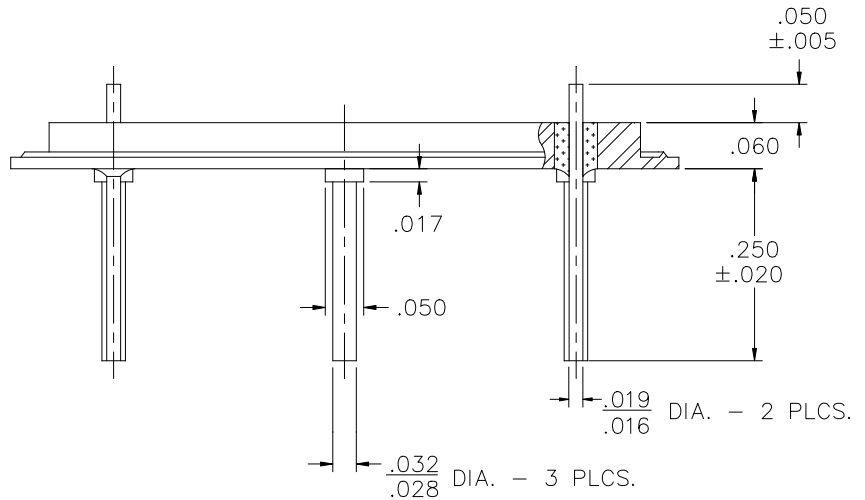
1. OPTION: RoHS COMPLIANT ELECTROLESS NICKEL PLATE OF 100 MICROINCHES MINIMUM FINAL PLATE.
2. OPTION: RoHS COMPLIANT ELECTROLESS NICKEL PLATE OF 100 MICROINCHES MINIMUM FOLLOWED BY A RoHS COMPLIANT LEAD FREE SOLDER COAT, ON LEADS ONLY.
3. OPTION: RoHS COMPLIANT ELECTROLESS NICKEL PLATE OF 100 MICROINCHES MINIMUM FOLLOWED BY A GOLD FLASH OF .99999 PURE 24 KARAT GOLD UP TO A MAX. OF 8 MICROINCHES.



DRAWN BY: E.T.W. 03-17-11		MATERIAL: SEE ABOVE		TOLERANCING PER ANSI Y14.5 .X ±.005 .XXX ±.005 .XX ±.005 ANG ±5° UNLESS OTHERWISE SPECIFIED		 6700 W. 47th TERR. MISSION, KS. 66203 TEL: 913-432-2487 FAX: 913-432-0570	
CHECKED BY:	APP. SPECS	SUPERSEDES	NEXT ASSY BLANK	SCALE: N.T.S.	FINISH: UNLESS OTHERWISE SPECIFIED		
APPROVED BY:	TITLE: .498x.870 5 PIN D.I.P. HEADER			FILE: UC00011A	PAGE 1 of 1		