

REV	DESCRIPTION OF REVISION	E.C.N.	BY	APPROVED	DATE
A	CORRECTED PATENT NO.		E.T.W.	M.F.	12-01-06
B	SEAL RING TO TOP EYELET ±.003 & RING TO BOT. OF FLG. .003 MAX.		E.C.	E.T.W.	04-09-15
C	NOTE WAS: STUD POST TO BE FLUSH OR BELOW FLUSH		E.C.	E.T.W.	06-16-15

PATENT NO.:  
US6.229.088

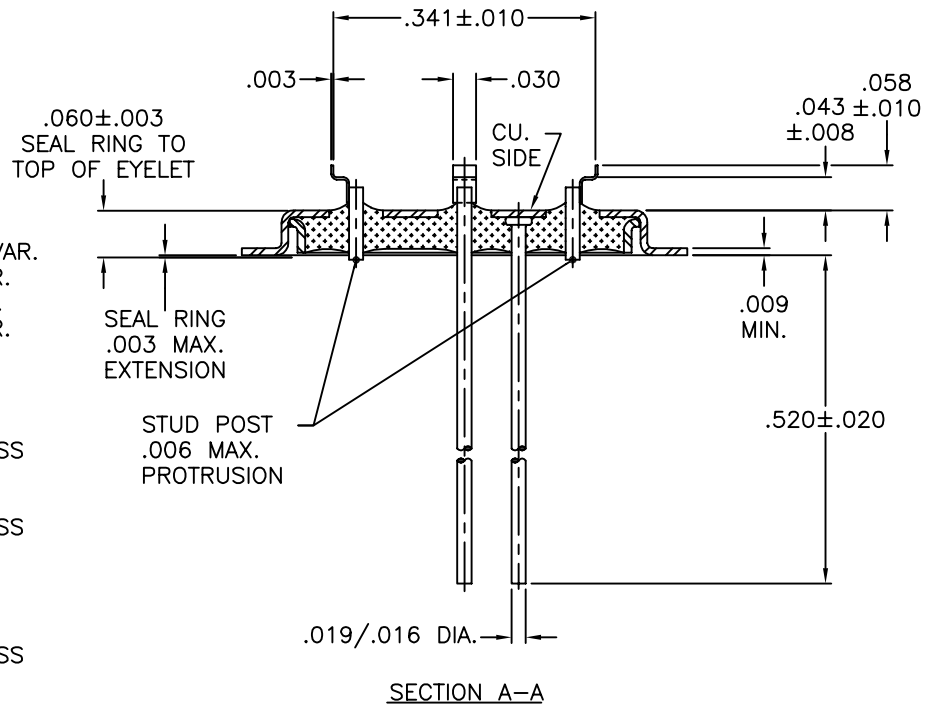
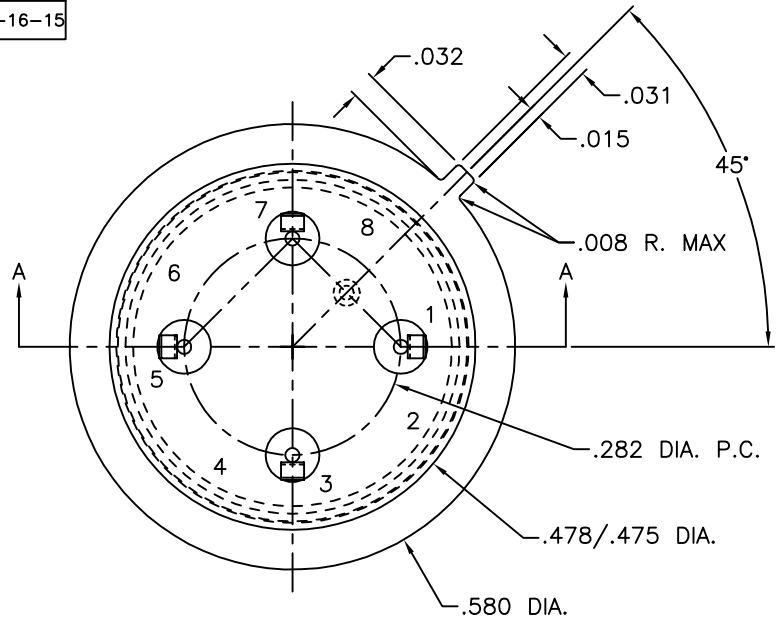

**MATERIAL:**

- EYELET - 30/70 COPPER CLAD KOVAR.
- SEAL RING - ASTM F-15 ALLOY, KOVAR.
- GLASS - 7052 OR EQUAL, OPAQUE.
- LEADS - ASTM F-15 ALLOY, KOVAR.
- MOUNT - NICKEL ALLOY.

**PLATING:**

1. OPTION: RoHS COMPLIANT ELECTROLESS NICKEL PLATE OF 100 MICROINCHES MINIMUM FINAL PLATE.
2. OPTION: RoHS COMPLIANT ELECTROLESS NICKEL PLATE OF 100 MICROINCHES MINIMUM FOLLOWED BY A RoHS COMPLIANT LEAD FREE SOLDER COAT, ON LEADS ONLY.
3. OPTION: RoHS COMPLIANT ELECTROLESS NICKEL PLATE OF 100 MICROINCHES MINIMUM FOLLOWED BY A GOLD FLASH OF .99999 PURE 24 KART GOLD UP TO A MAX. OF 8 MICROINCHES.

DRAWN BY: E.T.W. 02-23-06		MATERIAL: SEE ABOVE		TOLERANCING PER ANSI Y14.5 .X ± .005 .XXX ± .005 .XX ± .005 ANG ± 5° UNLESS OTHERWISE SPECIFIED		 Legacy Technologies Inc. 6700 W. 47th TERR. MISSION, KS. 66203 TEL: 913-432-2487 FAX: 913-432-0570	
CHECKED BY: E.T.W. 02-23-06		APP. SPECS	SUPERSEDES	NEXT ASSY		PART NUMBER: CWLP-T08-017J-CN330U RoHS	
APPROVED BY:		TITLE: HC-37/U WIDE FLANGE LOW PROFILE L.T.I. KANE P/N: 500-3105-1324-919 FOR AROUND .337 DIA. BLANK				FILE: HE00027A	PAGE 1 of 1