

REV	DESCRIPTION OF REVISION	E.C.N.	BY	APPROVED	DATE
A	CORRECTED PATENT NO.		E.T.W.	M.F.	12-01-06
B	WAS P/N: CWLP-40-BW-A-VS1045Y RoHS CORRECTED MAT'L WAS STAINLESS STEEL.		E.T.W.	J.T.	05-25-10

**PATENT NO.:**  
**US6.229.088**

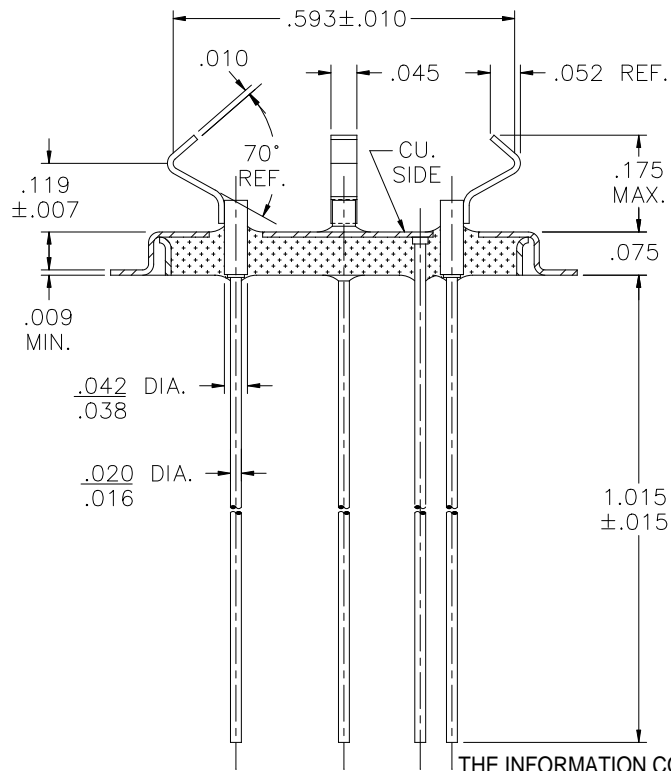
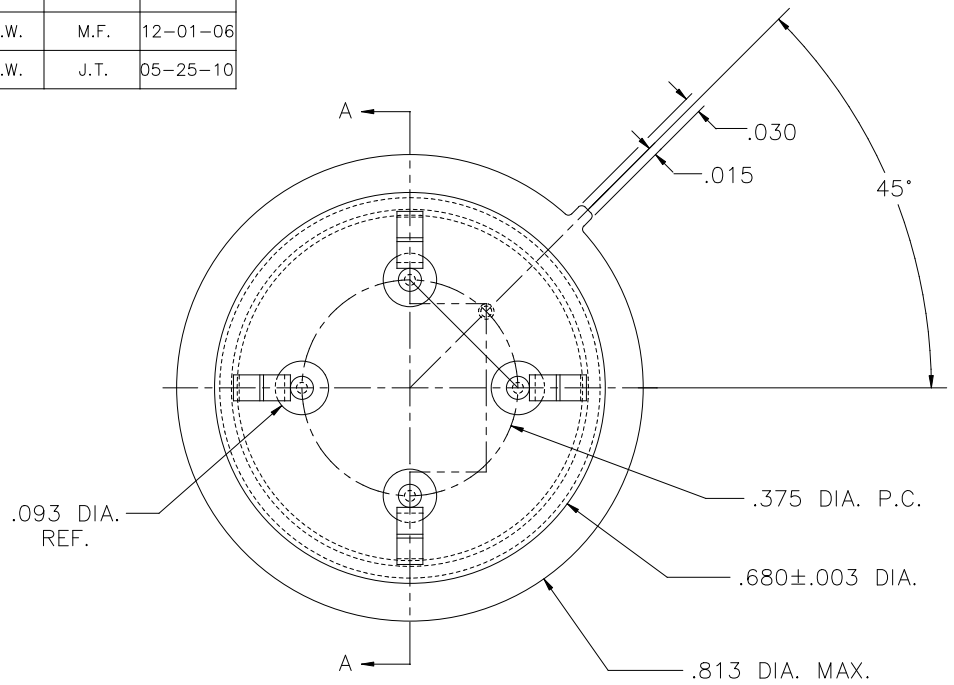

**MATERIAL:**

- EYELET - 30/70 COPPER CLAD KOVAR.
- SEAL RING - ASTM F-15 ALLOY, KOVAR.
- GLASS - 7052 OR EQUAL, OPAQUE.
- LEADS - ASTM F-15 ALLOY, KOVAR.
- MOUNT - NICKEL.

**PLATING:**

1. OPTION: RoHS COMPLIANT ELECTROLESS NICKEL PLATE OF 100 MICROINCHES MINIMUM FINAL PLATE.
2. OPTION: RoHS COMPLIANT ELECTROLESS NICKEL PLATE OF 100 MICROINCHES MINIMUM FOLLOWED BY A RoHS COMPLIANT LEAD FREE SOLDER COAT, ON LEADS ONLY.
3. OPTION: RoHS COMPLIANT ELECTROLESS NICKEL PLATE OF 100 MICROINCHES MINIMUM FOLLOWED BY A GOLD FLASH OF .99999 PURE 24 KARAT GOLD UP TO A MAX. OF 8 MICROINCHES.

THE INFORMATION CONTAINED IN THIS DRAWING IS THE SOLE PROPERTY OF LEGACY TECHNOLOGIES, INC.

ANY REPRODUCTION IN PART OR WHOLE WITHOUT THE WRITTEN PERMISSION OF LEGACY TECHNOLOGIES, INC. IS PROHIBITED.

DRAWN BY: E.T.W. 11-28-06		MATERIAL: SEE ABOVE		TOLERANCING PER ANSI Y14.5 .X ±.005 .XXX ±.005 .XX ±.005 ANG ±5° UNLESS OTHERWISE SPECIFIED		 Legacy Technologies Inc. 6700 W. 47th TERR. MISSION, KS. 66203 TEL: 913-432-2487 FAX: 913-432-0570	
CHECKED BY:		APP. SPECS	SUPERSEDES	NEXT ASSY	SCALE: 3:1		
APPROVED BY:		TITLE: L.T.I. / KANE P/N: 800-0817-1773-919 RoHS HC-40/U REF. LOW PROFILE W/ V-CLIP FOR AROUND .550 DIA. .040 THK. BLANK				PART NUMBER: CWLP-40-BW-A-VN1045Y RoHS	
		FILE: FF00010A		PAGE 1 of 1		B	