

REV	DESCRIPTION OF REVISION	E.C.N.	BY	APPROVED	DATE
A	WAS .059±.010		E.T.W.	J.T.	11-08-06
B	CORRECTED PATENT NO.		E.T.W.	M.F.	12-01-06
C	MOUNT MAT'L WAS ALLOY NICKEL		E.T.W.	E.T.W.	06-08-10
D	MOUNT WAS 200 NICKEL 1/4 HARD		E.T.W.	E.T.W.	05-23-11
E	MOUNT WAS 200 NICKEL, 1/2 HARD REVERT MAT'L BACK TO 1/4 HARD		E.C.	E.T.W.	10-06-14
F	SEAL RING TO TOP EYELET±.003 & RING TO BOT. OF FLG. .003 MAX.		E.C.	E.T.W.	04-09-15

PATENT NO.:
US6.229.088

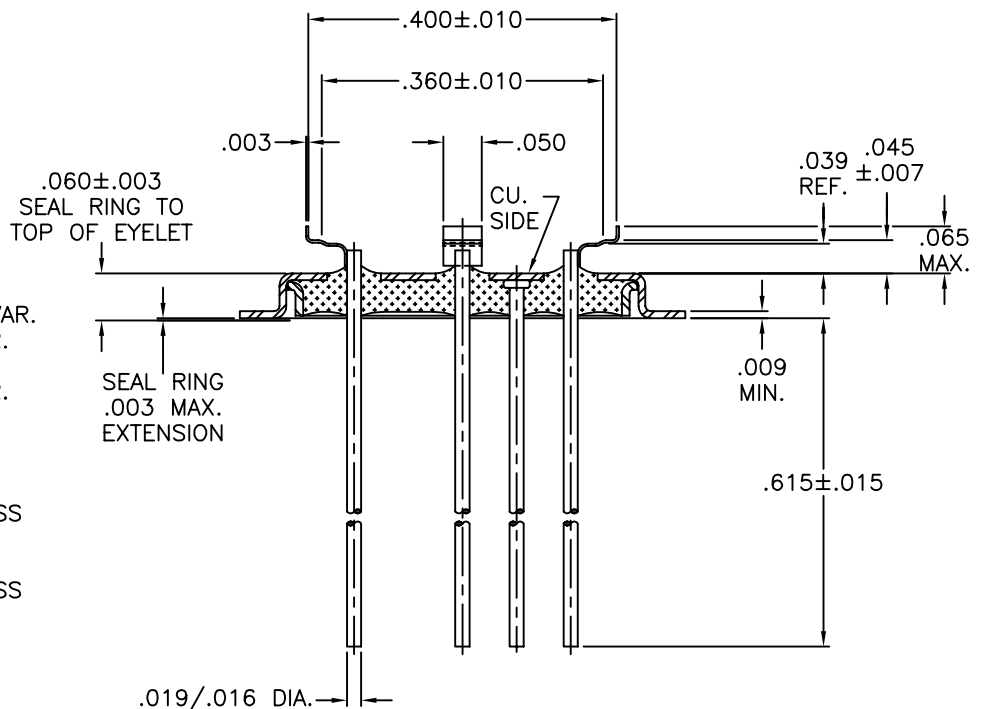
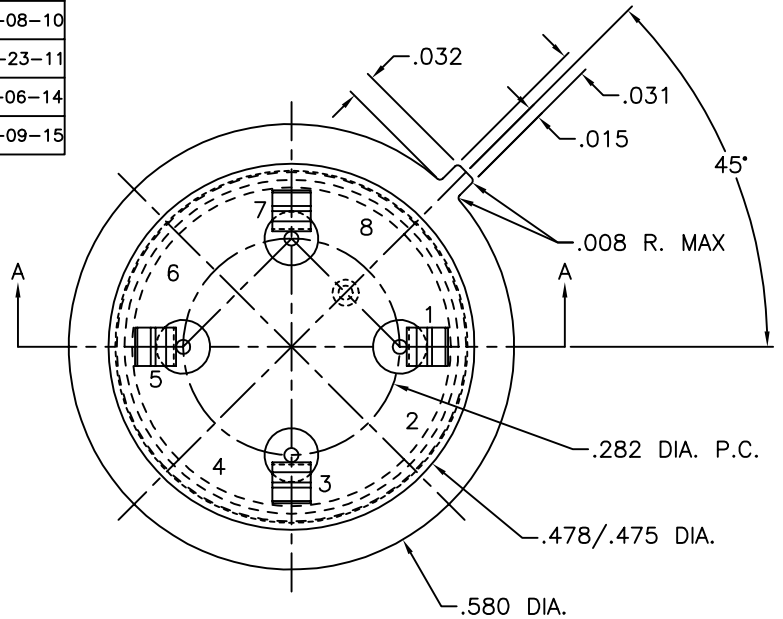

MATERIAL:

- EYELET - 30/70 COPPER CLAD KOVAR.
- SEAL RING - ASTM F-15 ALLOY, KOVAR.
- GLASS - 7052 OR EQUAL, OPAQUE.
- LEADS - ASTM F-15 ALLOY, KOVAR.
- MOUNT - 200 NICKEL, 1/4 HARD.

PLATING:

1. OPTION: RoHS COMPLIANT ELECTROLESS NICKEL PLATE OF 100 MICROINCHES MINIMUM FINAL PLATE.
2. OPTION: RoHS COMPLIANT ELECTROLESS NICKEL PLATE OF 100 MICROINCHES MINIMUM FOLLOWED BY A RoHS COMPLIANT LEAD FREE SOLDER COAT, ON LEADS ONLY.
3. OPTION: RoHS COMPLIANT ELECTROLESS NICKEL PLATE OF 100 MICROINCHES MINIMUM FOLLOWED BY A GOLD FLASH OF .99999 PURE 24 KART GOLD UP TO A MAX. OF 8 MICROINCHES.

DRAWN BY: E.T.W. 04-19-06	MATERIAL: SEE ABOVE			TOLERANCING PER ANSI Y14.5 .X ± .005 .XXX ± .005 .XX ± .005 ANG ± 5° UNLESS OTHERWISE SPECIFIED		 Legacy Technologies Inc. 6700 W. 47th TERR. MISSION, KS. 66203 TEL: 913-432-2487 FAX: 913-432-0570
	CHECKED BY: E.T.W. 04-19-06	APP. SPECS	SUPERSEDES	NEXT ASSY	SCALE: 4:1	
APPROVED BY:	TITLE: HC-37/U WIDE FLANGE LOW PROFILE L.T.I. / KANE P/N: 500-0106-1361-919 RoHS W/ CHAIR MOUNT (KANE MOUNT P/N: 1361)				PART NUMBER: CWLP-T08-017D-CN350J RoHS	F
					FILE: HE00004A	PAGE 1 of 1