

REV	DESCRIPTION OF REVISION	E.C.N.	BY	APPROVED	DATE
-----	-------------------------	--------	----	----------	------

17K-SS	.147
17J-SS	.235
17I-SS	.170
17H-SS	.250
17G-SS	.185
17F-SS	.140
17E-SS	.115
17D-SS	.195
17C-SS	.105
17B-SS	.155
17A-SS	.220
DASH	"A" DIM.

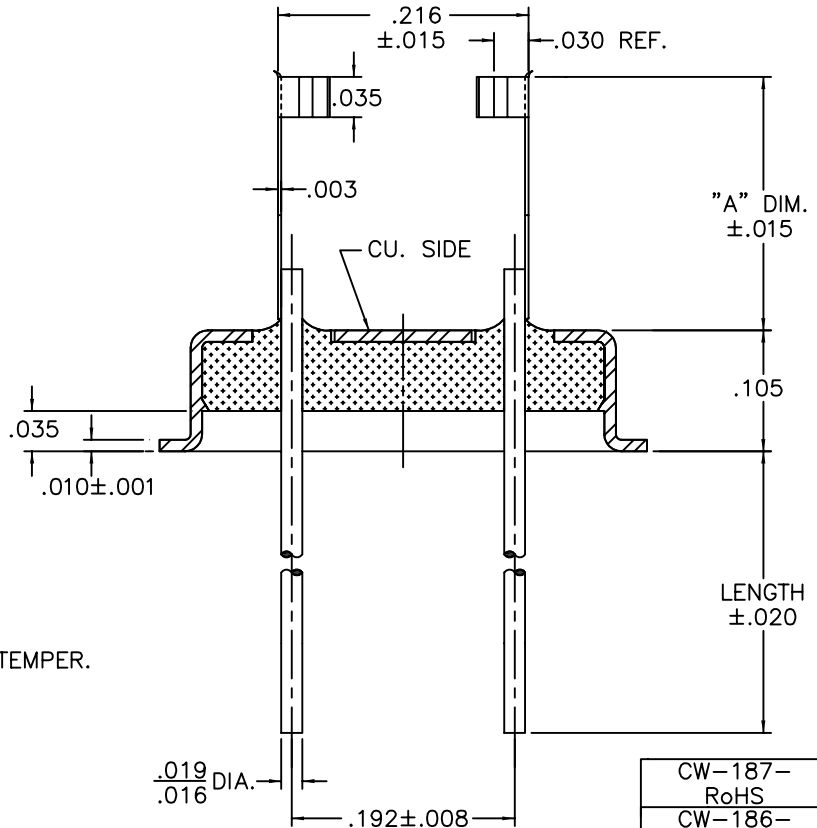
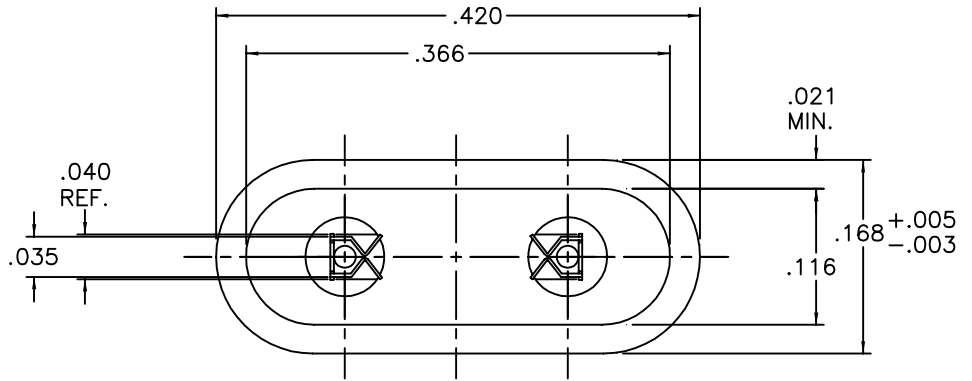

MATERIAL:

EYELET - 30/70 COPPER CLAD KOVAR.
 GLASS - 7052 OR EQUAL.
 LEADS - ASTM F-15 ALLOY, KOVAR.
 MOUNT - 301 STAINLESS STEEL, SPRING TEMPER.

PLATING:

- OPTION: RoHS COMPLIANT ELECTROLESS NICKEL PLATE OF 100 MICROINCHES MINIMUM FINAL PLATE.
- OPTION: RoHS COMPLIANT ELECTROLESS NICKEL PLATE OF 100 MICROINCHES MINIMUM FOLLOWED BY A RoHS COMPLIANT LEAD FREE SOLDER COAT, ON LEADS ONLY.
- OPTION: RoHS COMPLIANT ELECTROLESS NICKEL PLATE OF 100 MICROINCHES MINIMUM FOLLOWED BY A GOLD FLASH OF .99999 PURE 24 KARAT GOLD UP TO A MAX. OF 8 MICROINCHES.

CW-187-RoHS	.770
CW-186-RoHS	.620
CW-185-RoHS	.520
CW-184-RoHS	.375
CW-180-RoHS	1.520
PART NO.	LENGTH

DRAWN BY: E.T.W. 09-26-06	MATERIAL: SEE ABOVE	TOLERANCING PER ANSI Y14.5 .X ±.005 .XXX ±.005 .XX ±.005 ANG ±5° UNLESS OTHERWISE SPECIFIED		 Legacy Technologies Inc. 6700 W. 47th TERR. MISSION, KS. 66203 TEL: 913-432-2487 FAX: 913-432-0570
CHECKED BY: E.T.W. 09-26-06	APP. SPECS	SUPERSEDES	NEXT ASSY	
APPROVED BY:	TITLE: HC-43/U W/ TAB CLIP	SCALE: N.T.S.		FINISH: UNLESS OTHERWISE SPECIFIED <input checked="" type="checkbox"/>
				FILE: LA00012B
				PAGE 1 of 1