

THE INFORMATION CONTAINED IN THIS DRAWING IS THE SOLE PROPERTY OF LEGACY TECHNOLOGIES, INC. ANY REPRODUCTION IN PART OR WHOLE WITHOUT THE WRITTEN PERMISSION OF LEGACY TECHNOLOGIES, INC. IS PROHIBITED.

REV	DESCRIPTION OF REVISION	E.C.N.	BY	APPROVED	DATE
A	WAS .228±.010 & .306±.015		E.T.W.	M.F.	05-17-07
B	CHANGE CLIP DIM. TO MATCH 1205 CLIP BUT NICKEL SILVER		E.T.W.	M.F.	08-21-07
C	CHANGE CLIP DIM. TO MATCH 1205 CLIP AFTER WELDING		E.T.W.	M.F.	08-24-07
D	ADDED .012 REF. TO MOUNT FORM		E.T.W.	M.F.	08-28-07
E	CORRECTED MAT'L THK. WAS .005		E.T.W.	M.F.	08-30-07

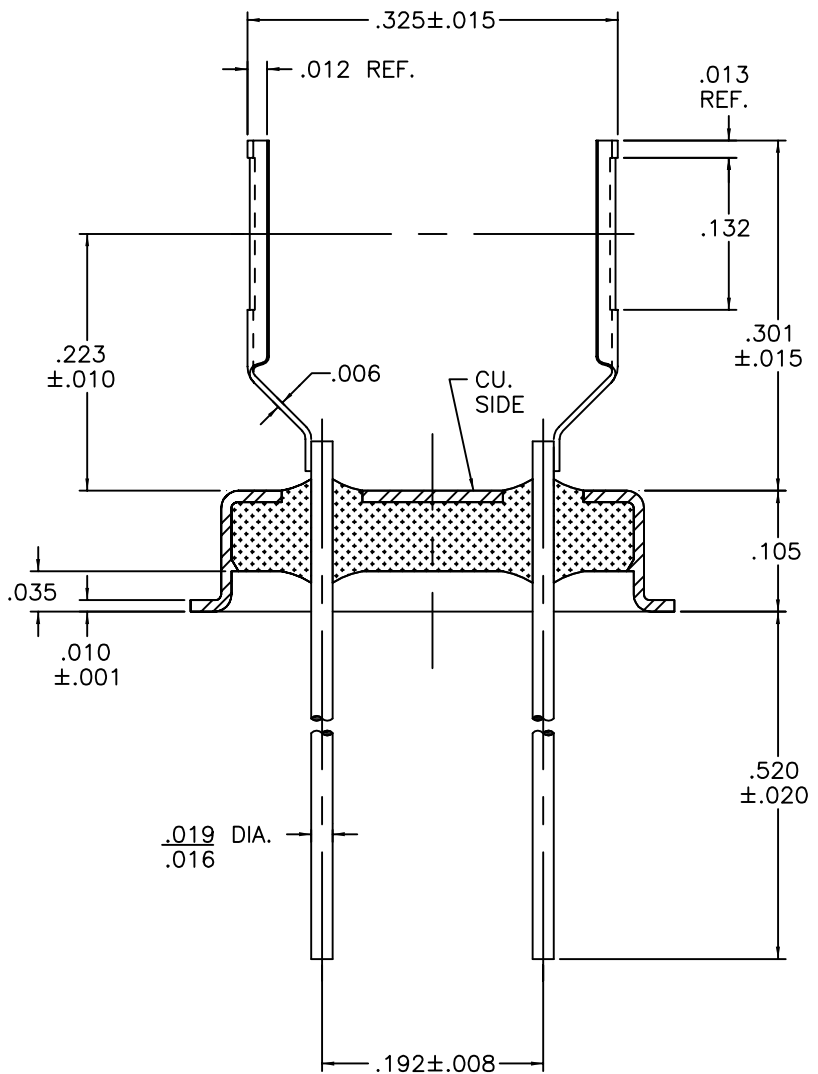
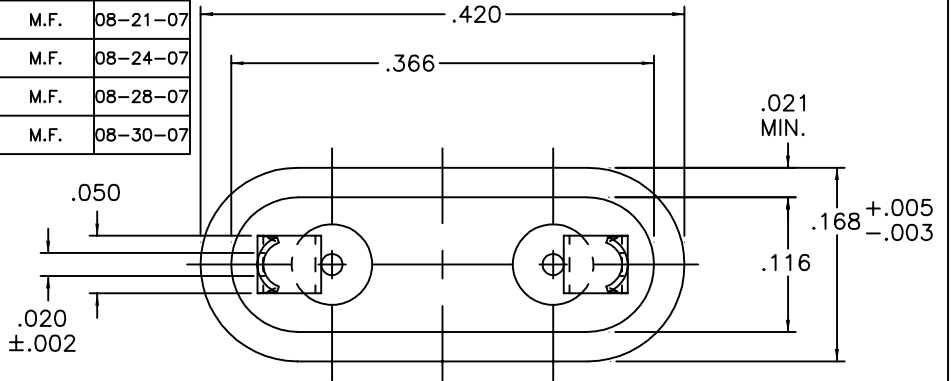

**MATERIAL:**

EYELET - 30/70 COPPER CLAD KOVAR.  
 GLASS - 7052 OR EQUAL.  
 LEADS - ASTM F-15 ALLOY, KOVAR.  
 MOUNT - NICKEL SILVER.

**PLATING:**

- OPTION: RoHS COMPLIANT ELECTROLESS NICKEL PLATE OF 100 MICROINCHES MINIMUM FINAL PLATE.
- OPTION: RoHS COMPLIANT ELECTROLESS NICKEL PLATE OF 100 MICROINCHES MINIMUM FOLLOWED BY A RoHS COMPLIANT LEAD FREE SOLDER COAT, ON LEADS ONLY.
- OPTION: RoHS COMPLIANT ELECTROLESS NICKEL PLATE OF 100 MICROINCHES MINIMUM FOLLOWED BY A GOLD FLASH OF .99999 PURE 24 KARAT GOLD UP TO A MAX. OF 8 MICROINCHES.

DRAWN BY: E.T.W. 07-24-06	MATERIAL: SEE ABOVE			TOLERANCING PER ANSI Y14.5 .X ± .005 .XXX ± .005 .XX ± .005 ANG ± 5° UNLESS OTHERWISE SPECIFIED		 Legacy Technologies Inc. 6700 W. 47th TERR. MISSION, KS. 66203 TEL: 913-432-2487 FAX: 913-432-0570
	CHECKED BY: E.T.W. 07-24-06	APP. SPECS	SUPERSEDES	NEXT ASSY	SCALE: 6:1	
APPROVED BY:	TITLE: HC-43/U W/ SLOT MOUNT L.T.I. / KANE P/N: 443-0105-2205-919 RoHS FOR .340 DIA. BLANK				PART NUMBER: CW-185-2205 RoHS	
				FILE: LE00038A	PAGE 1 of 1	