

REV	DESCRIPTION OF REVISION	E.C.N.	BY	APPROVED	DATE
-----	-------------------------	--------	----	----------	------

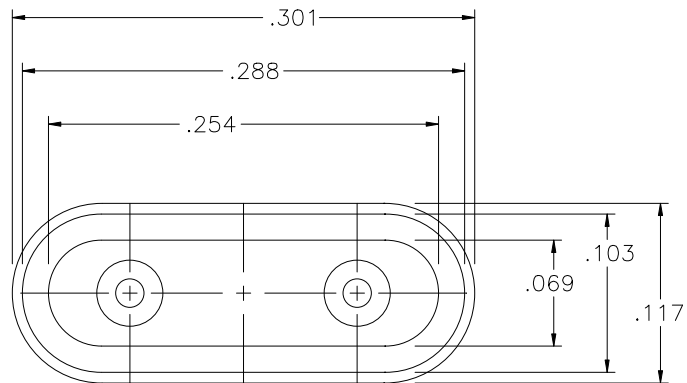

RR-45-015B RoHS	.040	.520	.016/.013
RR-45-015A RoHS	.030	.520	.016/.013
RR-45-B RoHS	.040	.520	.019/.016
RR-45-A RoHS	.030	.520	.019/.016
PART NO.	"A" DIM.	"B" DIM.	WIRE DIA.

MATERIAL:

EYELET- 1010 C.R.S. OR EQUAL.
 GLASS - 9013 OR EQUAL.
 LEADS - ASTM F-30, 52 ALLOY.

PLATING:

1. OPTION: RoHS COMPLIANT ELECTROLESS NICKEL PLATE OF 100 MICROINCHES MINIMUM FINAL PLATE.
2. OPTION: RoHS COMPLIANT ELECTROLESS NICKEL PLATE OF 100 MICROINCHES MINIMUM FOLLOWED BY A RoHS COMPLIANT LEAD FREE SOLDER COAT, ON LEADS ONLY.
3. OPTION: RoHS COMPLIANT ELECTROLESS NICKEL PLATE OF 100 MICROINCHES MINIMUM FOLLOWED BY A GOLD FLASH OF .99999 PURE 24 KARAT GOLD UP TO A MAX. OF 8 MICROINCHES.

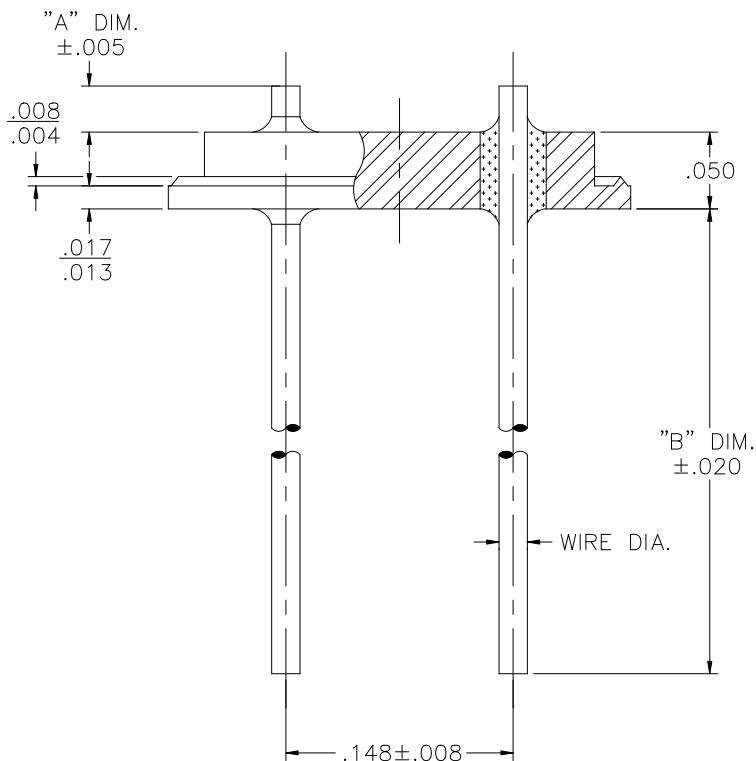

DRAWN BY: E.T.W. 07-01-11	MATERIAL: SEE ABOVE	TOLERANCING PER ANSI Y14.5 .X ±.005 .XXX ±.005 .XX ±.005 ANG ±5° UNLESS OTHERWISE SPECIFIED		 6700 W. 47th TERR. MISSION, KS. 66203 TEL: 913-432-2487 FAX: 913-432-0570	
CHECKED BY: E.T.W. 07-01-11	APP. SPECS	SUPERSEDES	NEXT ASSY		PART NUMBER:
APPROVED BY:	TITLE: HC-45/U RESISTANCE WELD TYPE (HC-52/U)	SCALE: 8:1		FINISH: UNLESS OTHERWISE SPECIFIED	SEE TABLE
FILE: VA00003C				PAGE	1 OF 1