

REV	DESCRIPTION OF REVISION	E.C.N.	BY	APPROVED	DATE
A	UPDATED DRAWING FORMAT. CORRECT FORK DIMS.		E.C.	E.T.W.	05-12-16

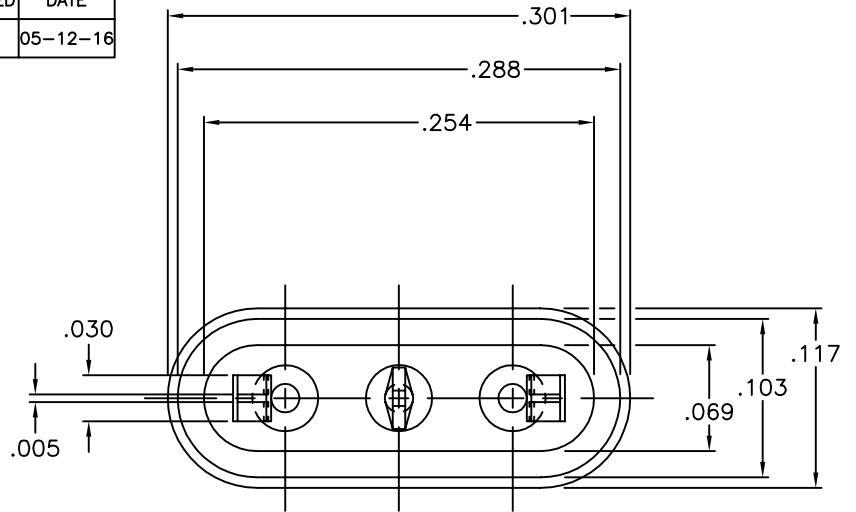

HM09-6 B.197	.197	.135
HM09-1 B.216	.216	.135
DASH	"A" DIM.	"B" DIM.

CENTER MOUNT
DETAIL

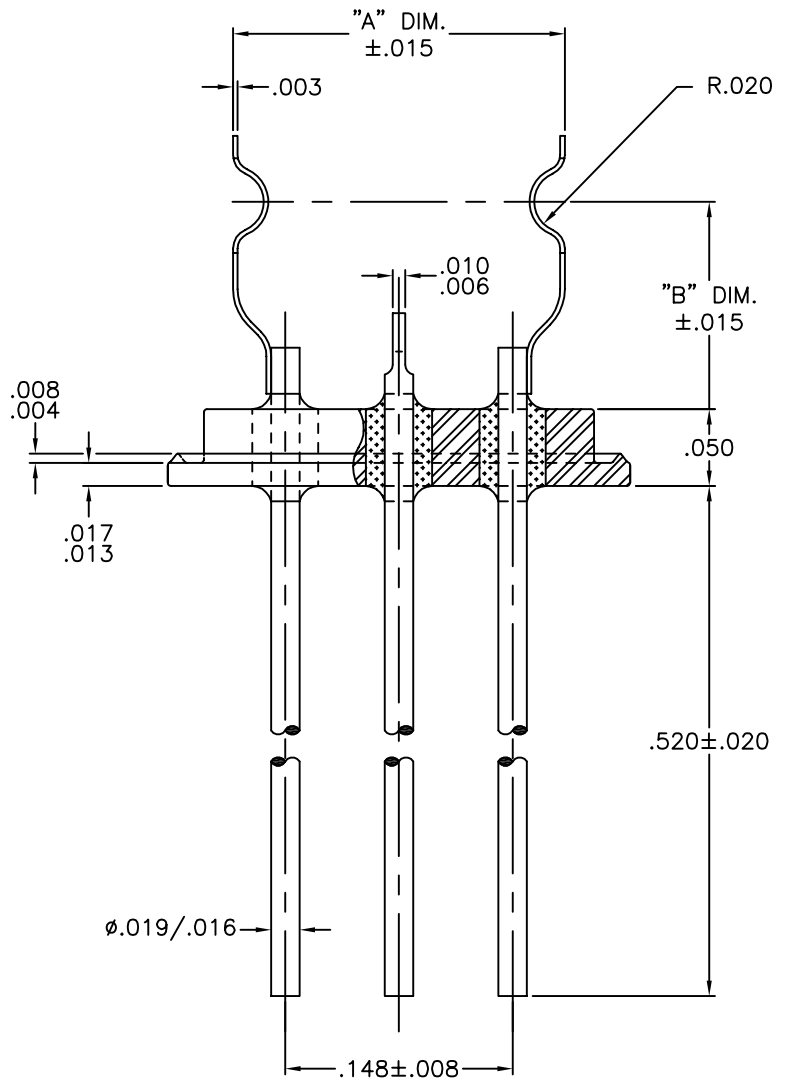
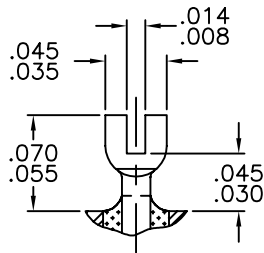

MATERIAL:

- EYELET - 1010 C.R.S. OR EQUAL.
- GLASS - 9013 OR EQUAL.
- LEADS - ASTM F-30, 52 ALLOY.
- MOUNT - C770 NICKEL SILVER, FULL HARD.

PLATING:

1. OPTION: RoHS COMPLIANT ELECTROLESS NICKEL PLATE OF 100 MICROINCHES MINIMUM FINAL PLATE.
2. OPTION: RoHS COMPLIANT LEAD FREE SOLDER COAT, ON LEADS ONLY.
3. OPTION: GOLD FLASH OF .99999 PURE 24 KART GOLD UP TO A MAX. OF 8 MICROINCHES.

DRAWN BY: E.T.W. 11-11-09	MATERIAL: SEE ABOVE	TOLERANCING PER ANSI Y14.5 .X ± .005 .XXX ± .005 .XX ± .005 ANG ± 5° UNLESS OTHERWISE SPECIFIED		 Legacy Technologies Inc. 6700 W. 47th TERR. MISSION, KS. 66203 TEL: 913-432-2487 FAX: 913-432-0570	
CHECKED BY: E.T.W. 11-11-09	APP. SPECS	SUPERSEDES	NEXT ASSY		PART NUMBER: RR-45-CIF-(DASH) RoHS
APPROVED BY: A.B. 11-11-09	TITLE: HC-45/U C.I.F. TYPE RESISTANCE WELD W/ HOOK MOUNT AND FORK MOUNT	SCALE: 8:1		FINISH: UNLESS OTHERWISE SPECIFIED <input checked="" type="checkbox"/>	FILE: VA00121A
				PAGE	1 of 1