

REV	DESCRIPTION OF REVISION	E.C.N.	BY	APPROVED	DATE
-----	-------------------------	--------	----	----------	------

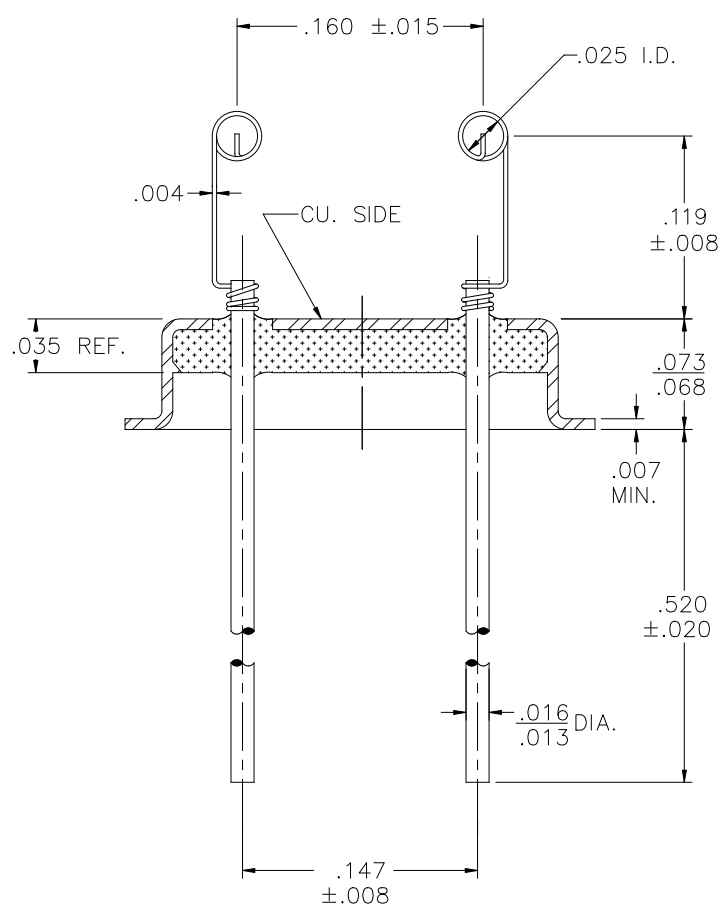
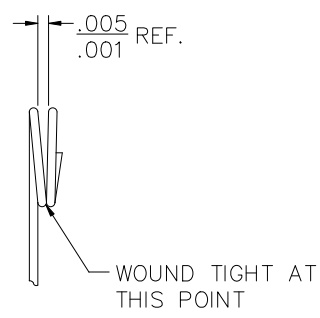
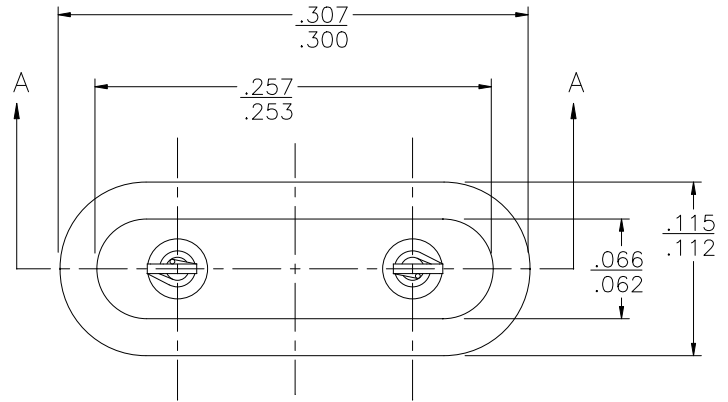

**MATERIAL:**

- EYELET - 30/70 CU. CLAD KOVAR.
- GLASS - 7052 OR EQUAL.
- LEADS - ASTM F-15 ALLOY, KOVAR.
- SPRING - DOUBLE TINNED MUSIC WIRE.
- SOLDER - PER QQ-S-571-D TIN LEAD ALLOY.  
(RoHS EXEMPTED PER ANNEX 7)

**PLATING:**

1. OPTION: RoHS COMPLIANT ELECTROLESS NICKEL PLATE OF 100 MICROINCHES MINIMUM FINAL PLATE.
2. OPTION: RoHS COMPLIANT ELECTROLESS NICKEL PLATE OF 100 MICROINCHES MINIMUM FOLLOWED BY A RoHS COMPLIANT LEAD FREE SOLDER COAT, ON LEADS ONLY.
3. OPTION: RoHS COMPLIANT ELECTROLESS NICKEL PLATE OF 100 MICROINCHES MINIMUM FOLLOWED BY A GOLD FLASH OF .99999 PURE 24 KARAT GOLD UP TO A MAX. OF 8 MICROINCHES.

SECTION A-A

DRAWN BY: E.T.W. 10-04-06		MATERIAL: SEE ABOVE		TOLERANCING PER ANSI Y14.5 .X ±.005 .XXX ±.005 .XX ±.005 ANG ±5° UNLESS OTHERWISE SPECIFIED		 6700 W. 47th TERR. MISSION, KS. 66203 TEL: 913-432-2487 FAX: 913-432-0570
CHECKED BY:	APP. SPECS	SUPERSEDES	NEXT ASSY	SCALE: N.T.S.	FINISH: UNLESS OTHERWISE SPECIFIED	
APPROVED BY:	TITLE: HC-45/U W/ SPRING MOUNT			FILE: MB00019A	PAGE 1 OF 1	