

REV	DESCRIPTION OF REVISION	E.C.N.	BY	APPROVED	DATE
-----	-------------------------	--------	----	----------	------

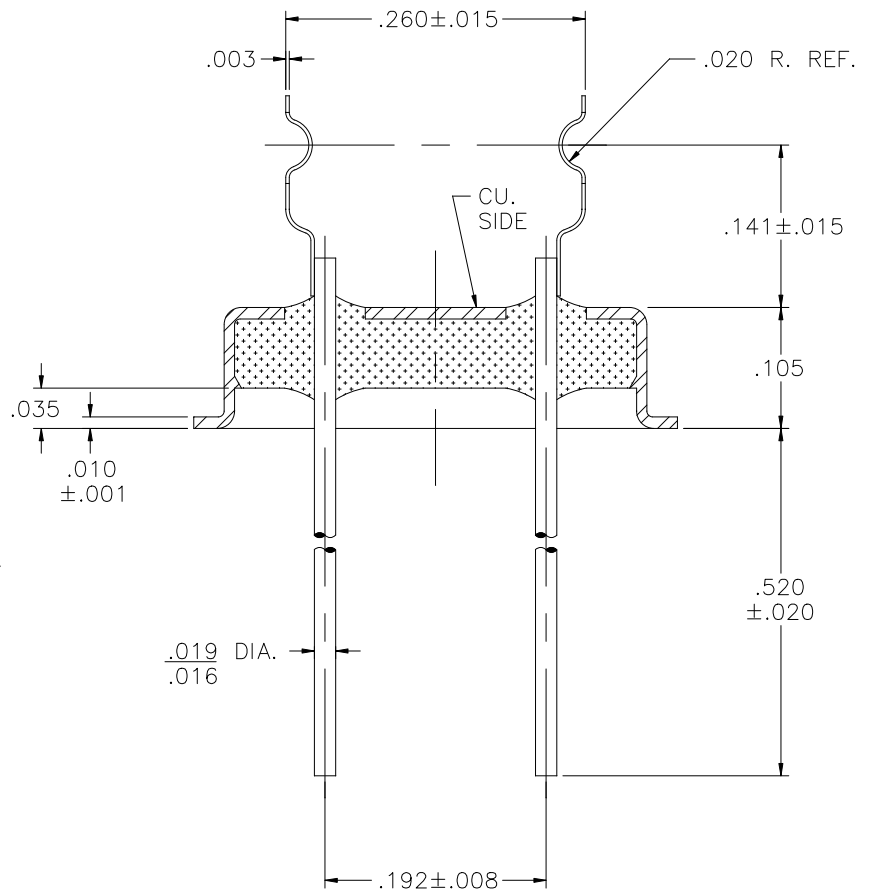
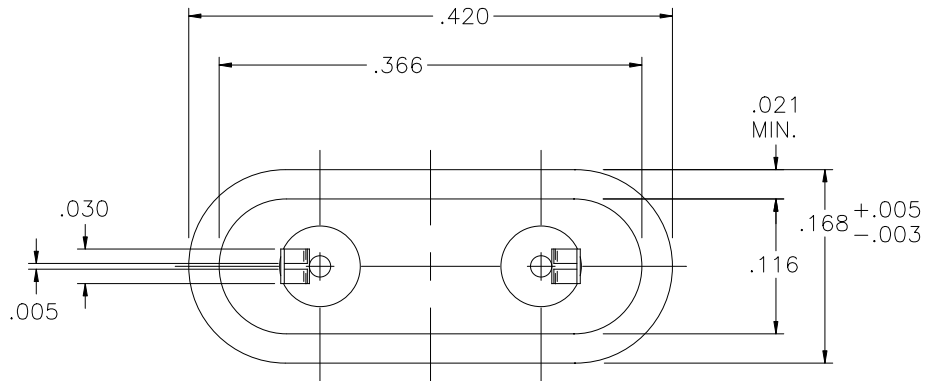

**MATERIAL:**

EYELET- 30/70 COPPER CLAD KOVAR.  
 GLASS - 7052 OR EQUAL.  
 LEADS - ASTM F-15 ALLOY, KOVAR.  
 MOUNT- C770 NICKEL SILVER, FULL HARD.

**PLATING:**

1. OPTION: RoHS COMPLIANT ELECTROLESS NICKEL PLATE OF 100 MICROINCHES MINIMUM FINAL PLATE.
2. OPTION: RoHS COMPLIANT ELECTROLESS NICKEL PLATE OF 100 MICROINCHES MINIMUM FOLLOWED BY A RoHS COMPLIANT LEAD FREE SOLDER COAT, ON LEADS ONLY.
3. OPTION: RoHS COMPLIANT ELECTROLESS NICKEL PLATE OF 100 MICROINCHES MINIMUM FOLLOWED BY A GOLD FLASH OF .99999 PURE 24 KARAT GOLD UP TO A MAX. OF 8 MICROINCHES.

DRAWN BY: E.T.W. 03-22-06		MATERIAL: SEE ABOVE		TOLERANCING PER ANSI Y14.5 .X ±.005 .XXX ±.005 .XX ±.005 ANG ±5° UNLESS OTHERWISE SPECIFIED		 <b>Legacy Technologies Inc.</b> 6700 W. 47th TERR. MISSION, KS. 66203 TEL: 913-432-2487 FAX: 913-432-0570
CHECKED BY:	APP. SPECS	SUPERSEDES	NEXT ASSY	SCALE: 6:1	FINISH: UNLESS OTHERWISE SPECIFIED	
APPROVED BY:	TITLE: HC-43/U TYPE W/ HOOK MOUNT FOR .260 DIA. BLANK				PART NUMBER: CW-185-HM09-1 B.260 RoHS	FILE: LA00030C
						PAGE 1 of 1