

REV	DESCRIPTION OF REVISION	E.C.N.	BY	APPROVED	DATE
A	ADDED MOUNT TEMPER, EYELET WD. WAS .120X.305, BODY .105X.290		E.T.W.		11-30-07

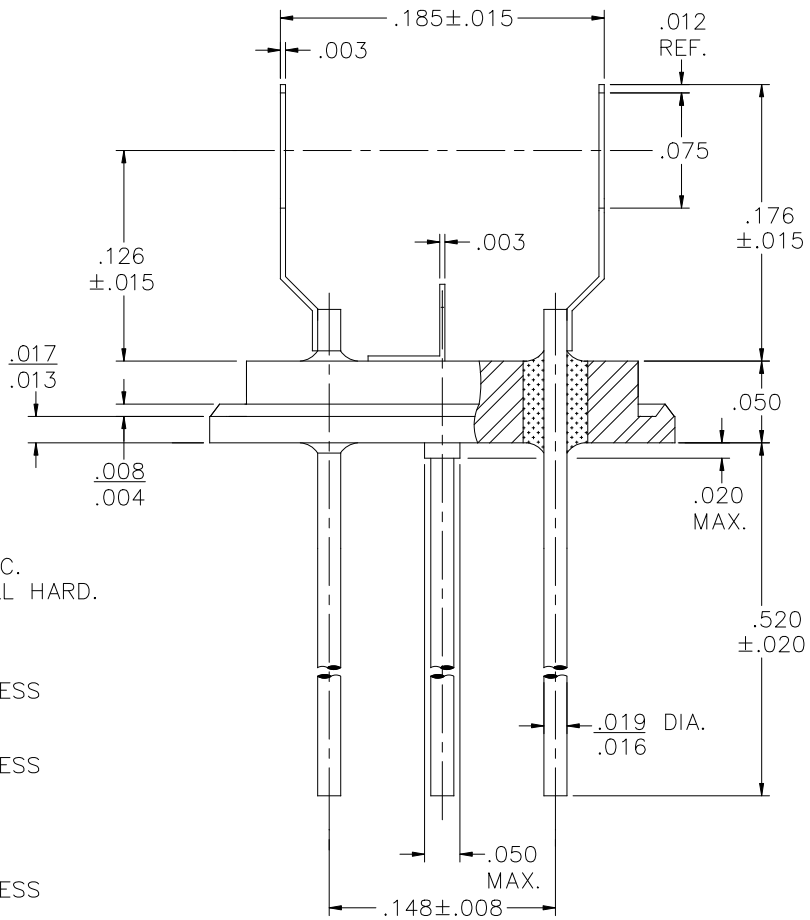
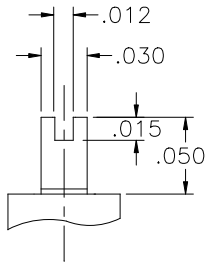
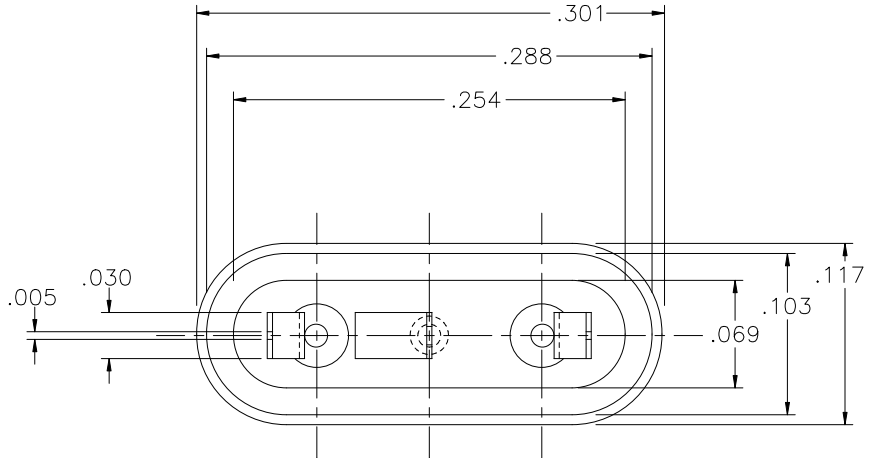

MATERIAL:

- EYELET - 1010 C.R.S. OR EQUAL.
- GLASS - 9013 OR EQUAL.
- LEADS - ASTM F-30, 52 ALLOY.
- BRAZE - BT-VTG CU. AG. EUTECTIC.
- MOUNTS - C770 NICKEL SILVER, FULL HARD.

PLATING:

1. OPTION: RoHS COMPLIANT ELECTROLESS NICKEL PLATE OF 100 MICROINCHES MINIMUM FINAL PLATE.
2. OPTION: RoHS COMPLIANT ELECTROLESS NICKEL PLATE OF 100 MICROINCHES MINIMUM FOLLOWED BY A RoHS COMPLIANT LEAD FREE SOLDER COAT, ON LEADS ONLY.
3. OPTION: RoHS COMPLIANT ELECTROLESS NICKEL PLATE OF 100 MICROINCHES MINIMUM FOLLOWED BY A GOLD FLASH OF .99999 PURE 24 KARAT GOLD UP TO A MAX. OF 8 MICROINCHES.

DRAWN BY: E.T.W. 11-08-07		MATERIAL: SEE ABOVE		TOLERANCING PER ANSI Y14.5 .X ±.005 .XXX ±.005 .XX ±.005 ANG ±5° UNLESS OTHERWISE SPECIFIED		 Legacy Technologies Inc. 6700 W. 47th TERR. MISSION, KS. 66203 TEL: 913-432-2487 FAX: 913-432-0570	
CHECKED BY:	APP. SPECS	SUPERSEDES	NEXT ASSY	SCALE: N.T.S.	FINISH: UNLESS OTHERWISE SPECIFIED		
APPROVED BY:	TITLE: HC-45/U C.G.F. RESISTANCE WELD W/ TACK FORK & SLOT MOUNT FOR .194 DIA. BLANK			FILE: VA00104A	PAGE 1	OF 1	