

REV	DESCRIPTION OF REVISION	E.C.N.	BY	APPROVED	DATE
-----	-------------------------	--------	----	----------	------

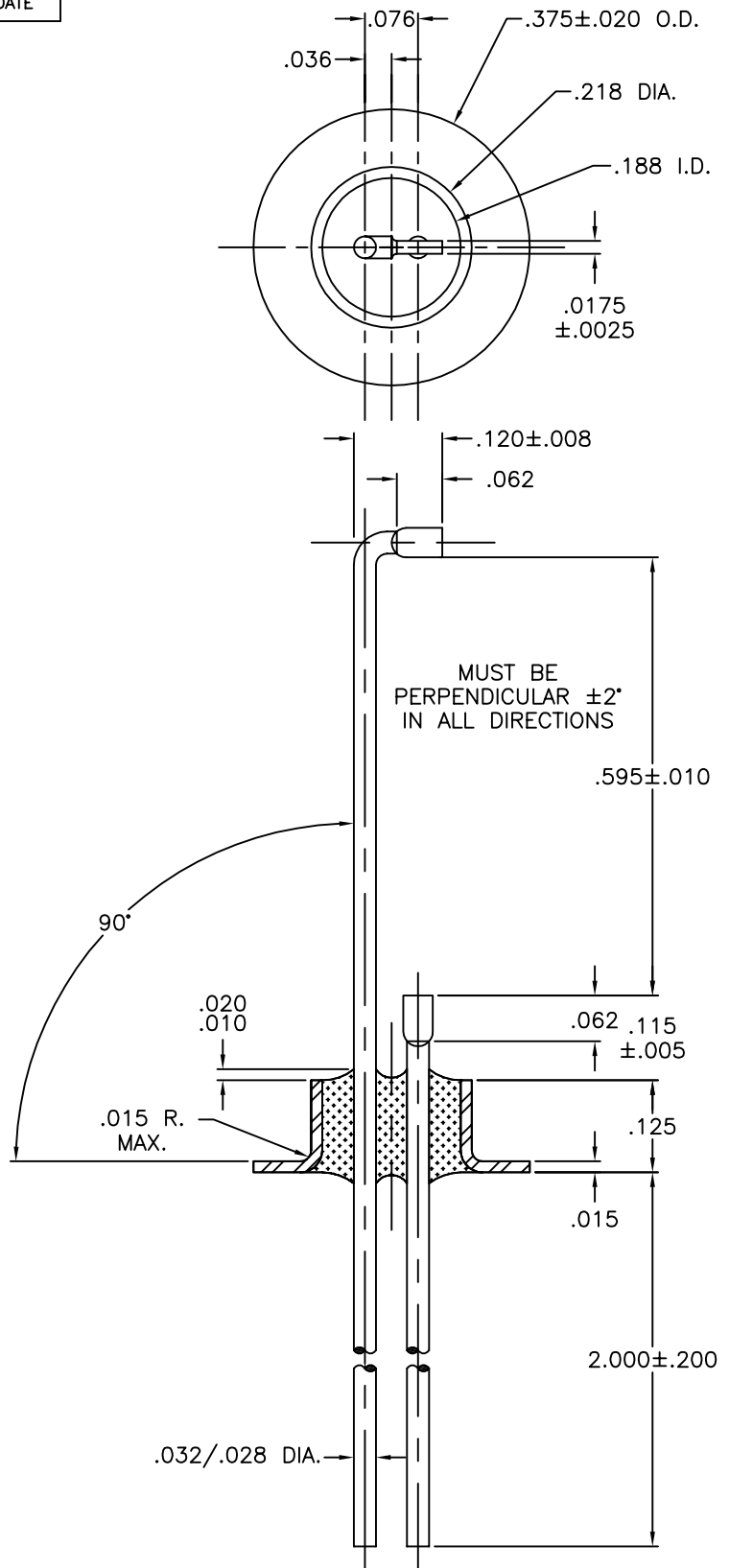

MATERIAL:

EYELET - ASTM F-15 ALLOY, KOVAR.
 GLASS - 7052 OR EQUAL.
 LEADS - ASTM F-15 ALLOY, KOVAR.

PLATING:

1. RoHS COMPLIANT ELECTROLESS NICKEL PLATE OF 100 MICROINCHES MINIMUM FOLLOWED BY 10 MICROINCHES MINIMUM OF ELECTROLYTIC GOLD PER MIL-G-45204B, TYPE 3, GRADE A, CLASS 00 REF.

DRAWN BY: E.T.W. 03-09-10	MATERIAL: SEE ABOVE			TOLERANCING PER ANSI Y14.5		 Legacy Technologies Inc.	6700 W. 47th TERR. MISSION, KS. 66203 TEL: 913-432-2487 FAX: 913-432-0570
	CHECKED BY: E.T.W. 03-09-10	APP. SPECS	SUPERSEDES	NEXT ASSY	.X $\pm .005$.XXX $\pm .005$.XX $\pm .005$ ANG $\pm 5^\circ$ UNLESS OTHERWISE SPECIFIED		
APPROVED BY:	TITLE: FEED THRU L.T.I. / KANE P/N: 160-0002-0000-920			SCALE: 4:1	FINISH: UNLESS OTHERWISE SPECIFIED <input checked="" type="checkbox"/>	FILE: EA00089A	PAGE 1 of 1