

SCTE Seminar

Optical Transport - November 2016

Britton W. Bowman

Principal Systems Engineer

Email: britton.bowman@infinera.com



Optical Transport – Brief History

- Commercial optical transport systems in the 1970s-90s were discrete systems transporting information over a single wavelength and a dedicated pair of fibers per system
- Improvements in electronic, laser, and fiber manufacturing increased the capacities from 6Mbps to 2.5Gbps per fiber during this time
- Fiber availability on existing fiber plants was being exhausted with the demands of these discrete systems in the late 1990s/early 2000s, enter Wave Division Multiplexing (WDM)
- Improvements in WDM technology, modulation formats, electronics, lasers, and fiber have increased capacity per fiber to the Multi-Tb/s ranges to satisfy the every increasing bandwidth demands on today's market

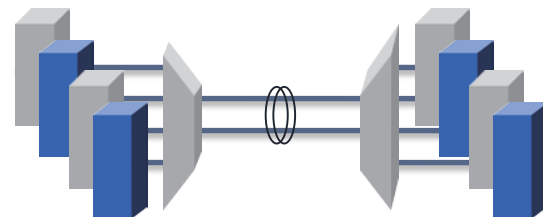
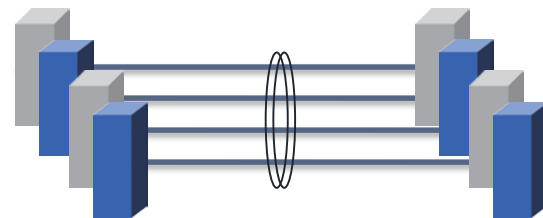

Optical Transport Basics – WDM

Wave Division Multiplexing (WDM) increased the transport capacity of the optical fiber by converting each input signal to a discrete wavelength that is passively combined for transmission over a single fiber.

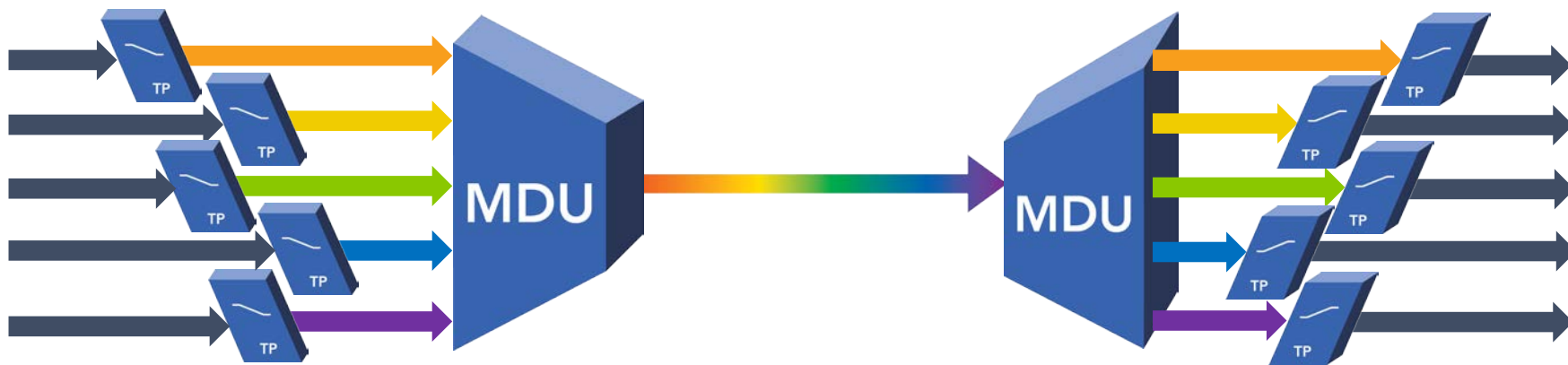

CWDM – Coarse Wave Division Multiplexing
DWDM – Dense Wave Division Multiplexing

Optical Transport Basics – Optical Bands

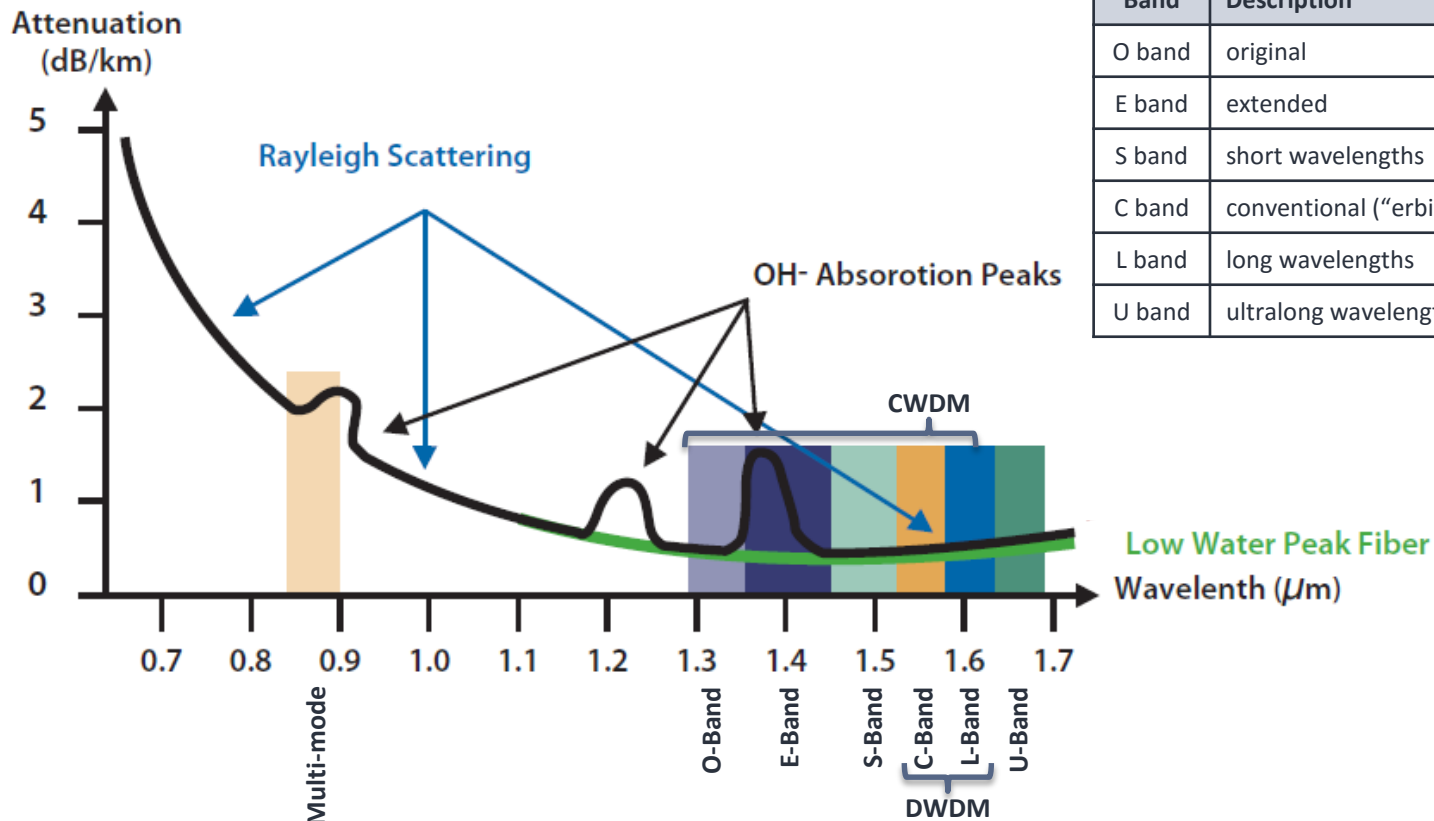

Band	Description	Wavelength range
O band	original	1260–1360 nm
E band	extended	1360–1460 nm
S band	short wavelengths	1460–1530 nm
C band	conventional (“erbium window”)	1530–1565 nm
L band	long wavelengths	1565–1625 nm
U band	ultralong wavelengths	1625–1675 nm

Optical Transport Basics – CWDM

Course Wave Division Multiplexing (CWDM)

- ▶ Wider wavelengths equate to lower cost lasers and passive Mux/Demux Units (MDU)
- ▶ Transceiver optics are usually fixed wavelength
- ▶ Typical CWDM systems provide 8 λ in the 1470-1610nm range
- ▶ Extended CWDM systems provide an additional 8 λ in the 1270-1450nm range

CWDM Fiber-pair

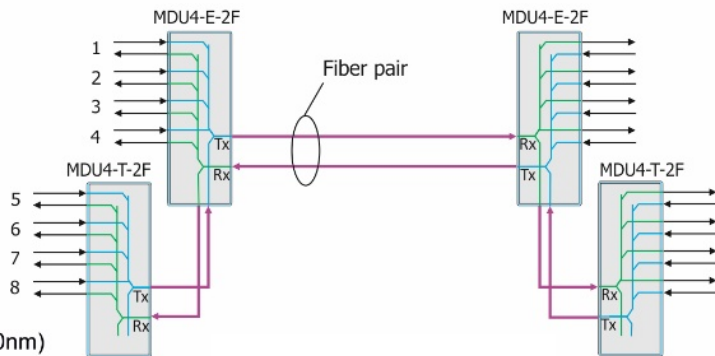

8ch config (1470 - 1610nm)

4ch MDU-E

4ch MDU-T

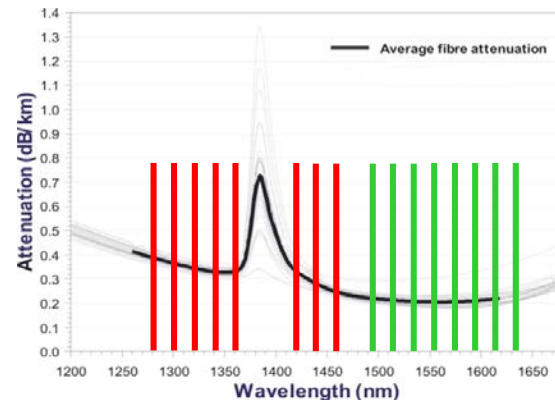

Optical Transport Basics – DWDM 50GHz Grid

Dense Wave Division Multiplexing (DWDM)

- ▶ Narrow wavelengths equate to precision lasers for center frequency stability and larger port count MDUs, per channel costs slightly higher when compare to CWDM
- ▶ Typical 50GHz spaced DWDM systems provide $\sim 80\lambda$ in the C-Band range (1530-1565nm)
- ▶ Transceivers are available in fixed and tunable wavelengths

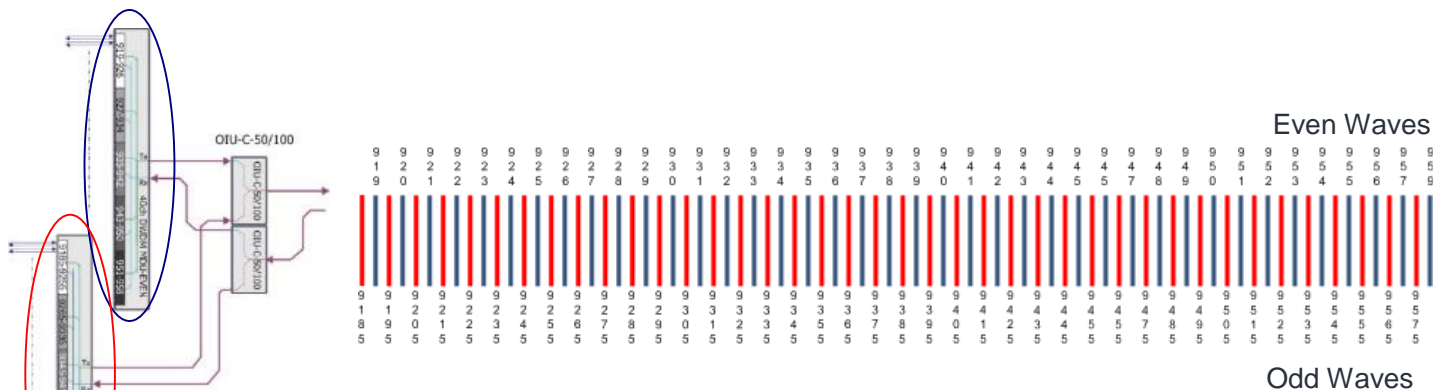

Optical Transport Basics – Optical Amplification

Attenuation within the fiber strand and all optical components in the path of the optical signal limits the transmission distance. Optical amplifiers can be used to regain optical power thus extending the transmission distance.

- The erbium-doped fiber amplifiers (EDFA) use a high powered pump laser at a different wavelength (980nm typ) to excite the erbium ions in a section of doped fiber.
- The erbium atoms give up some of their energy in the form of photons that are in phase with the DWDM wavelengths, thus providing amplification
- The EDFA amplification window coincides with the C-Band and L-Band
- Optimized EDFAs with different lengths of doped fiber are typically used for each band

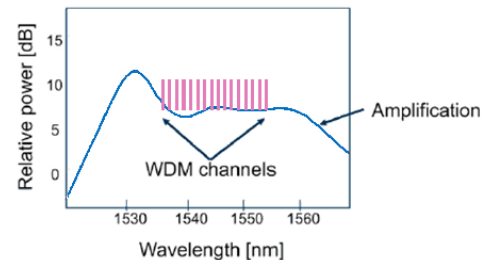
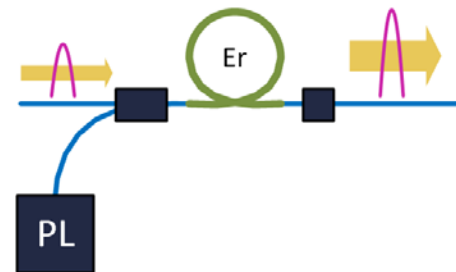

Optical Transport Basics – DWDM Power Balancing

Power Balancing of the DWDM spectrum

- ▶ Critical for multi-segment systems utilizing amplifiers
- ▶ Even distribution of gain over the entire spectrum
- ▶ Maintains best OSNR for all wavelengths
- ▶ Balancing attenuates the levels all wavelengths to be equal before amplification
- ▶ Manual balancing can be a cumbersome and long process
- ▶ Dynamic balancing allows for easy wavelength additions

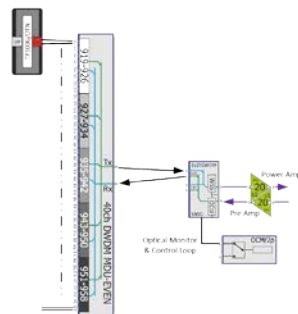
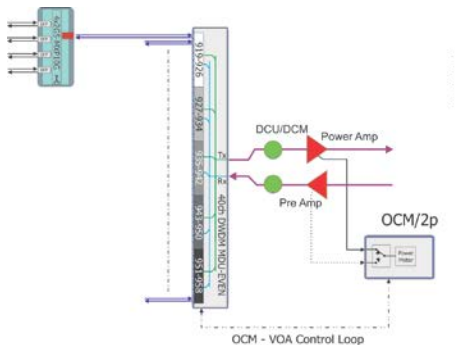
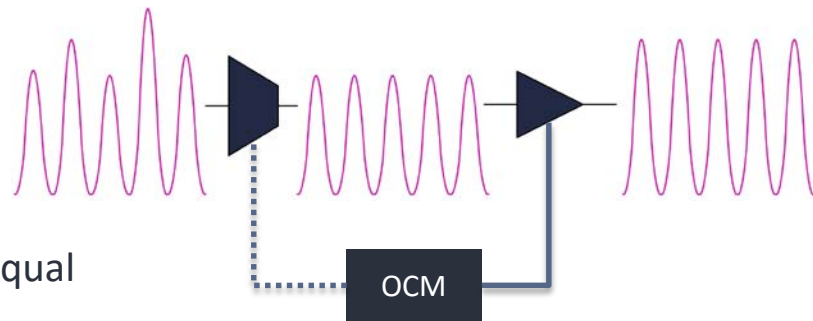

Optical Transport Basics – Optical Amplification

- A balanced or flat spectrum is important to ensure a fair sharing of the optical power across all amplified wavelengths
- The optical fiber attenuates the wavelengths differently across the spectrum, introducing what is referred to as fiber tilt
- The EDFAs are typically optimized for a certain gain or a range of gain in which the gain tilt is opposite of the fiber tilt, thus counteracting the fiber tilt, providing an even distribution of gain over the entire spectrum

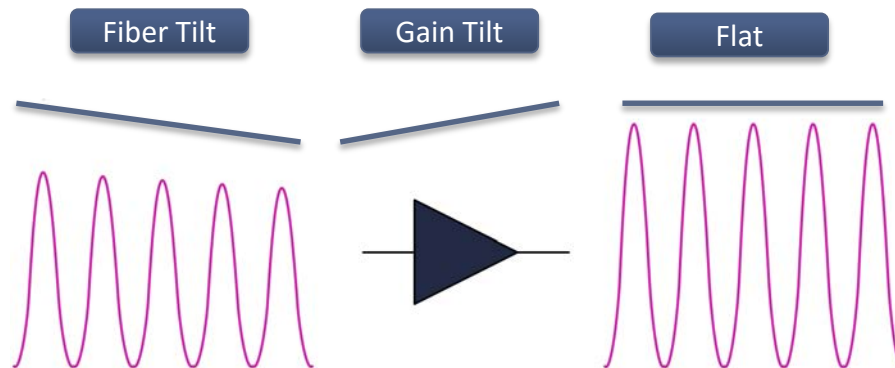

Optical Transport Basics – Dispersion Compensation

- Transmission distance is also limited by dispersion, spreading of the optical pulses as they travel through the fiber
- Dispersion is due to that high frequencies travel faster than lower frequencies thus distorting the signal shape and causing interference between wavelengths leading to signal degrade

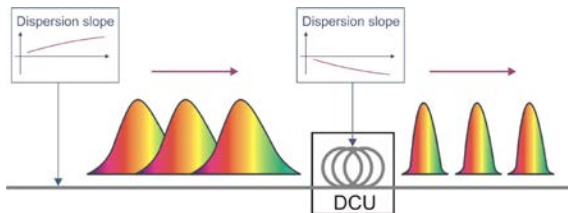
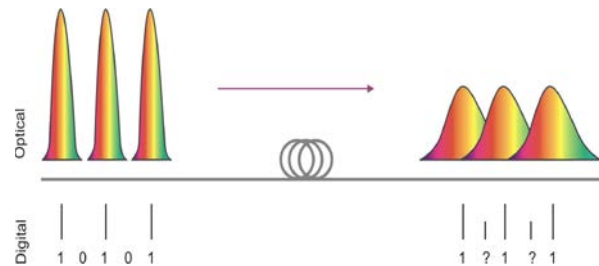

- Fiber based Dispersion compensating units (DCU's) can negate the effects of dispersion with fiber that contains a negative dispersion slope to counteract the effects of dispersion over a give length of fiber

- Bragg grating dispersion compensating modules (DCM's) are constructed to reflect leading parts of the pulse later than the lagging parts, thus compressing the pulse and counteracting the effects of dispersion
- DCMs have a lower insertion loss than DCUs

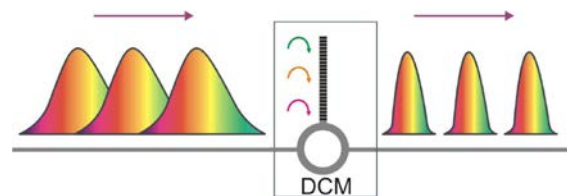

Coherent detection/modulation & multi-carrier signals
reduce the need for physical Dispersion Compensation

Optical Transport Basics – Regeneration

Regeneration converts the optical signal to electrical and back to optical, thus performing re-amplification, re-shaping, re-timing (3R) of the signal to provide a good clean signal for the extending the transmission distance or hand off the client.

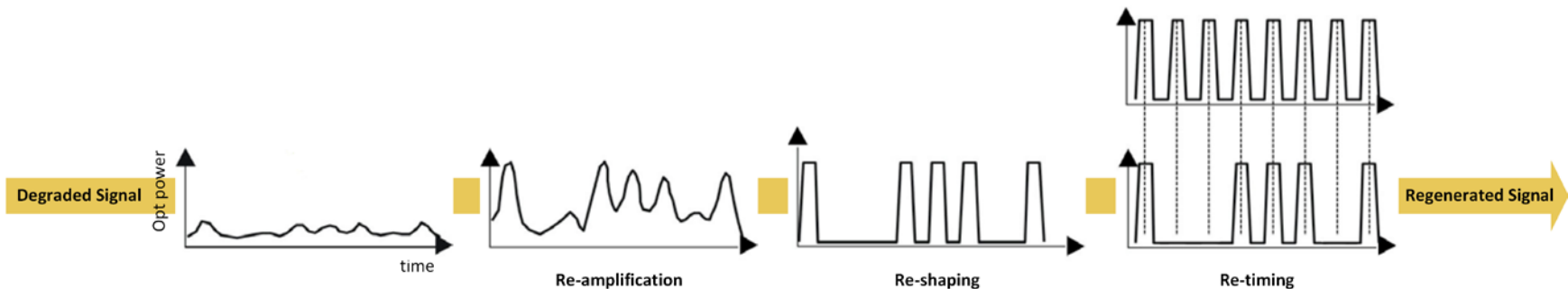

Optical Transport Basics – DWDM Flex-grid & Super-Channels

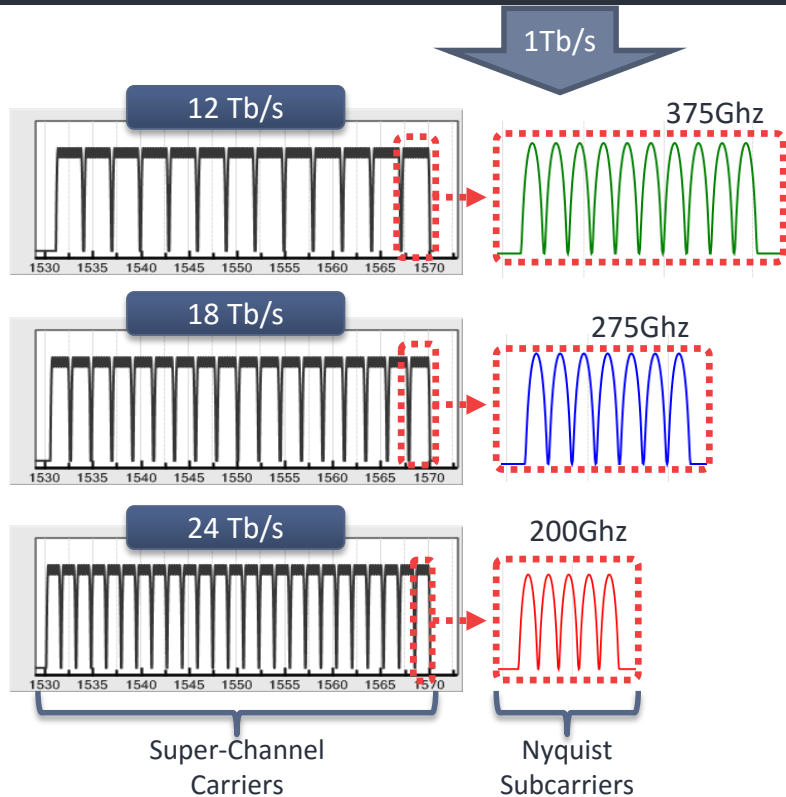

Flex-grid

- ▶ Allows for variable channel sizing and tighter spacing between channels
- ▶ Increases usable amplifier spectrum ~25%
- ▶ Flex-grid channels have a granularity of 12.5 GHz, that can be combined to create an aggregate super-channel with a spectral width of $N \times 12.5$ GHz, to accommodate any combination of optical carriers, modulations, and data rate
- ▶ A Super-channel carrier is comprised of multiple subcarriers that are modulated to provide increased data rate per super-channel



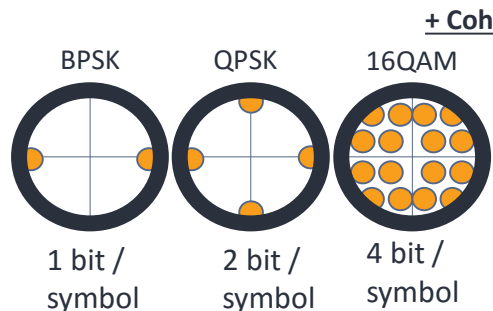

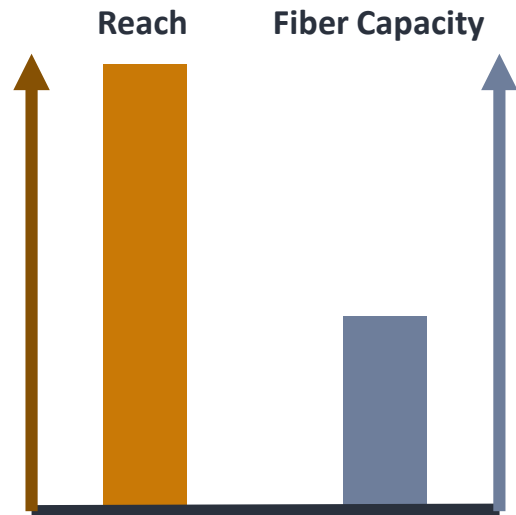

Optical Transport Basics – Coherent Modulation



- Encoding digital information onto an analogue carrier using symbols will increase the data rate
- Using Polarization will double the amount of bits per symbol
- Dispersion compensation can be done in the electronic domain
- Higher modulation formats inversely affect the reach



Optical Transport Basics – Optical Component Growth

Data Rate	~1G	2.5G	10G	100G	500G	1T
Modulation	NRZ	NRZ	NRZ	Phase Modulation (e.g. xPSK)	Phase Modulation (e.g. xPSK)	Phase Modulation (e.g. xQAM)
Required Components						

Many additional optical components are required for higher data rates

Optical Transport Basics – Infinera Photonic Integrated Circuit

Infinera's Coherent Photonic Integrated Circuit (PIC)

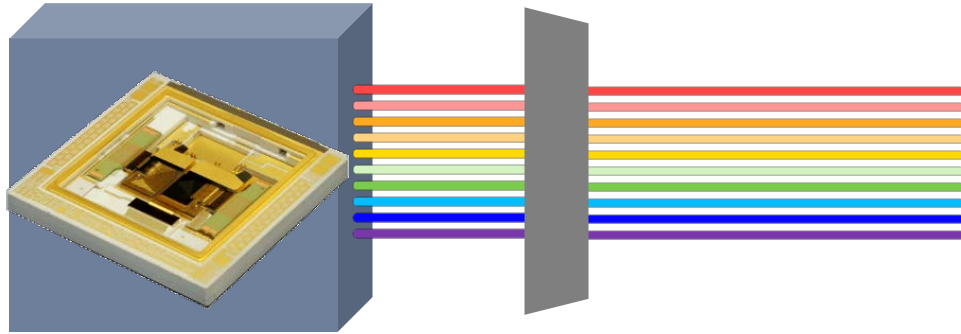
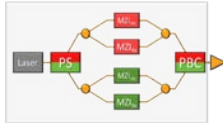
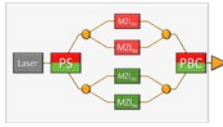
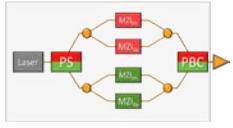
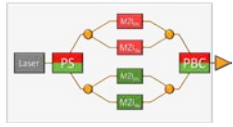
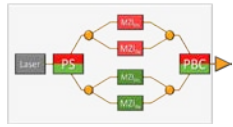
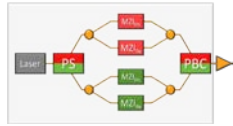

PIC Technology

- Combines nearly all the transport capabilities in a single package
- Enables multi-Tb/s optical transport
- Lowers power consumption of the overall solution
- Provides a highly reliable optical transport

Topology and Networking



Optical Transport Basics – Physical Topologies

- Point-to-Point (P2P) topology provides direct connection and dedicated fiber or wavelength between nodes.
- Add/Drop capabilities are typically incorporated
- This topology has limited protection options

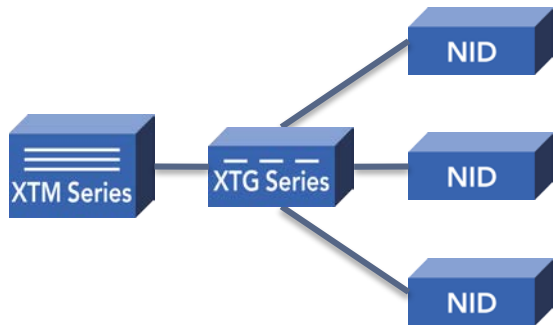
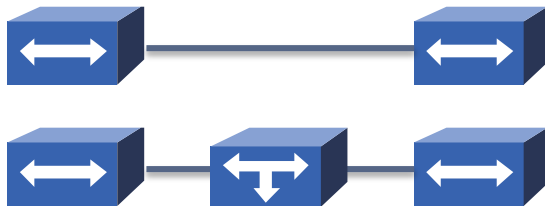

- Point-to-Multipoint (P2MP) is a branching topology where multiple fibers or wavelengths are bundled to a branching point and then distributed between the end nodes
- This topology also has limited protection options

Optical Transport Basics – Physical Topologies

- Star topology provides direct connection and dedicated fiber or wavelength between a single node and several individual nodes.
- This topology has limited protection options

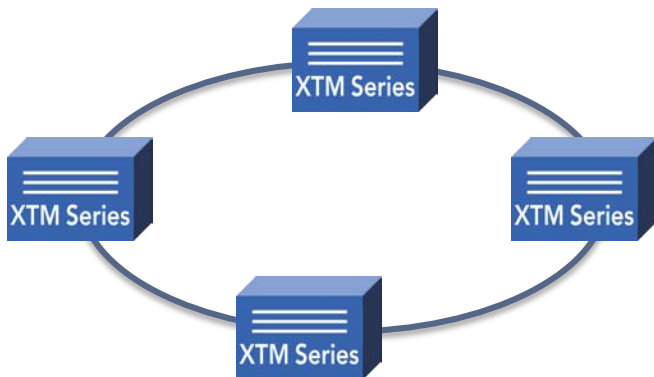
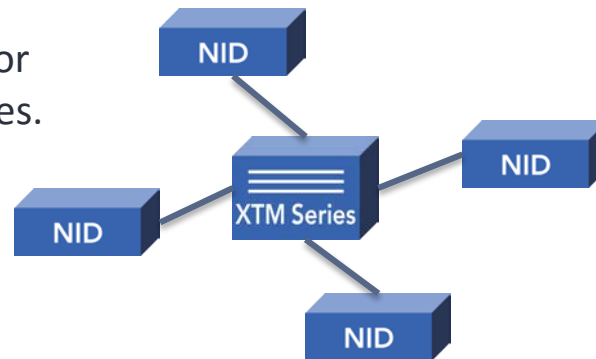

- Ring topologies provide continuous connectivity to all nodes in CW/CCW directions over a dedicated fiber or wavelength
- Typically comprised of two-degree ROADM units for remote/dynamic reconfiguration of wavelengths
- Resiliency is inherent to this topology with two connections for every node

Optical Transport Basics – Physical Topologies

- Mesh topologies provide continuous connectivity between all nodes in multiple directions over a dedicated fiber or wavelength
- Typically comprised of multi-degree ROADM units for remote/dynamic reconfiguration of wavelengths and/or OTN, MPLS, or Ethernet switches for dynamic switching
- This is a highly resilient network as every node is connected to every other node

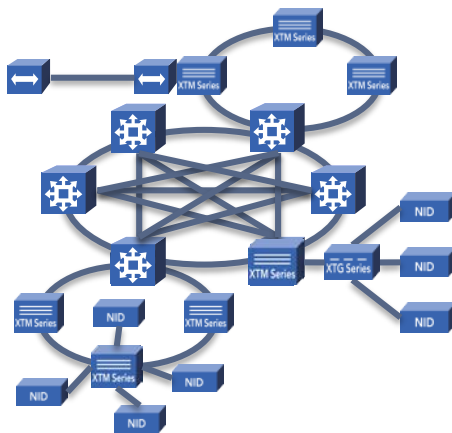
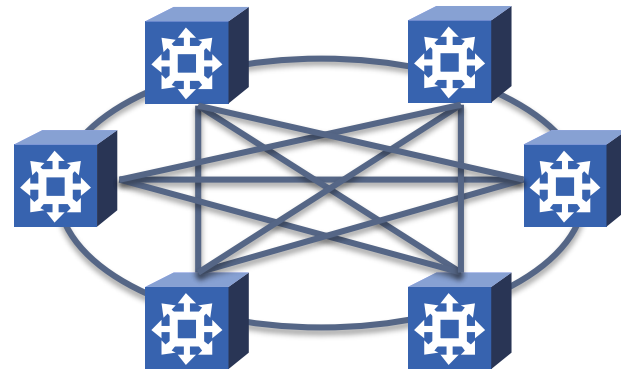

- Typically these topology types are used jointly in the different areas of a large transport network; such as the Access, Metro/Regional, Long Haul, and Ultra Long Haul
- The right combination will be a balance of cost, performance, and resiliency for the appropriate areas of the network

Optical Transport Basics - Networking

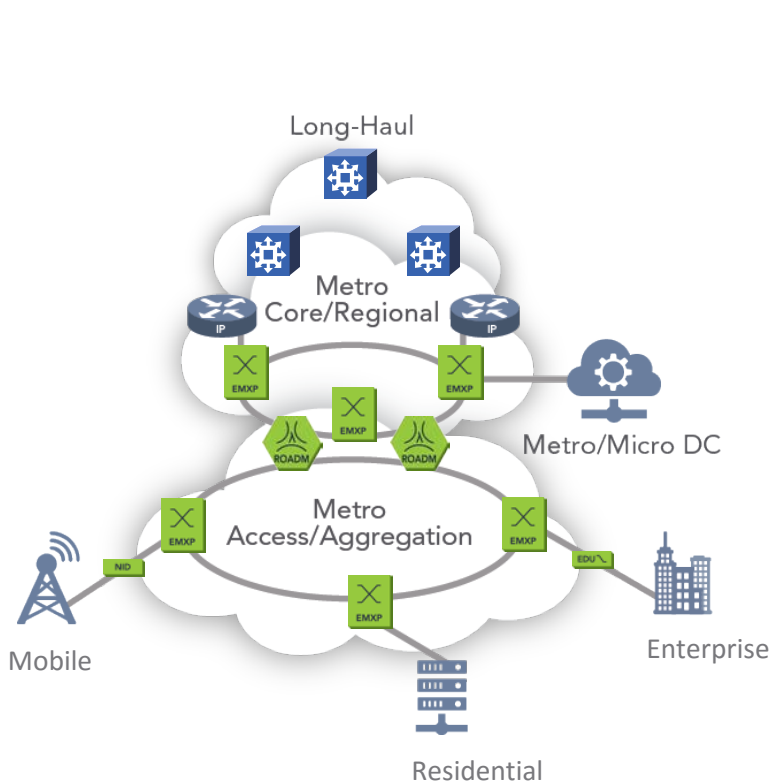

Long Haul/Subsea

- Application-agnostic
- Operational scale and capacity

Metro

- Flexible architecture
- Enables End-to-End intergration

Access

- Strong application focus
- High density, low power

Basics of Optical Transport – Access Networks

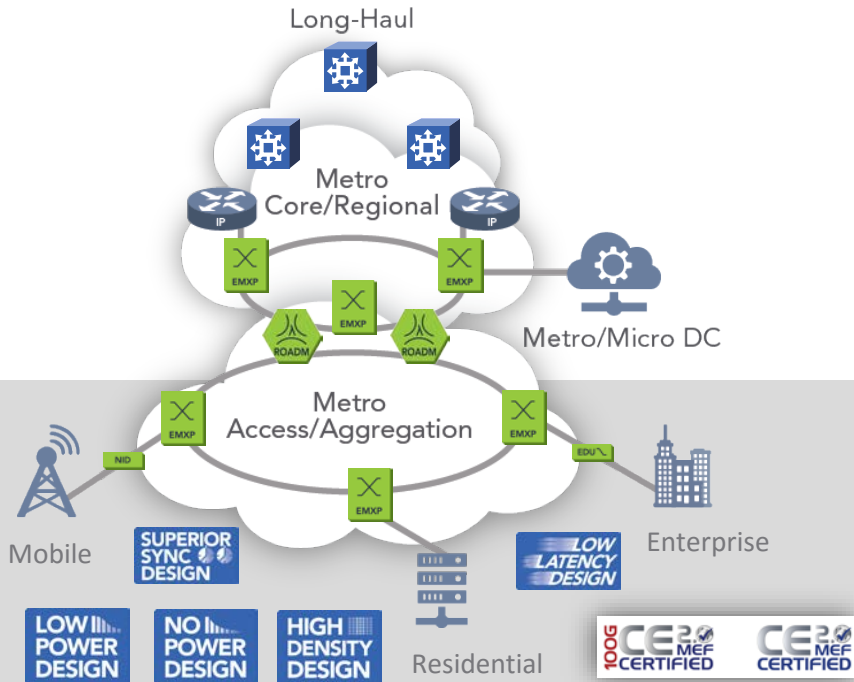

- ▶ Typically comprised of P2P, P2MP, and Star physical topologies
- ▶ Transport distances are usually range from 1 to 10s km
- ▶ Passive CWDM and DWDM technologies are used to maximize fiber utilization for the services provided
- ▶ Technologies like WDM-PON, G-PON, E-PON, & HFC utilize WDM for transport
- ▶ Applications include HFC, FTTx, Business Services, Mobile Backhaul, and Video Distribution to name a few.
- ▶ Aggregation of sub-rate signals is typically used to maximize the bandwidth utilization

Basics of Optical Transport – Access Application, Example

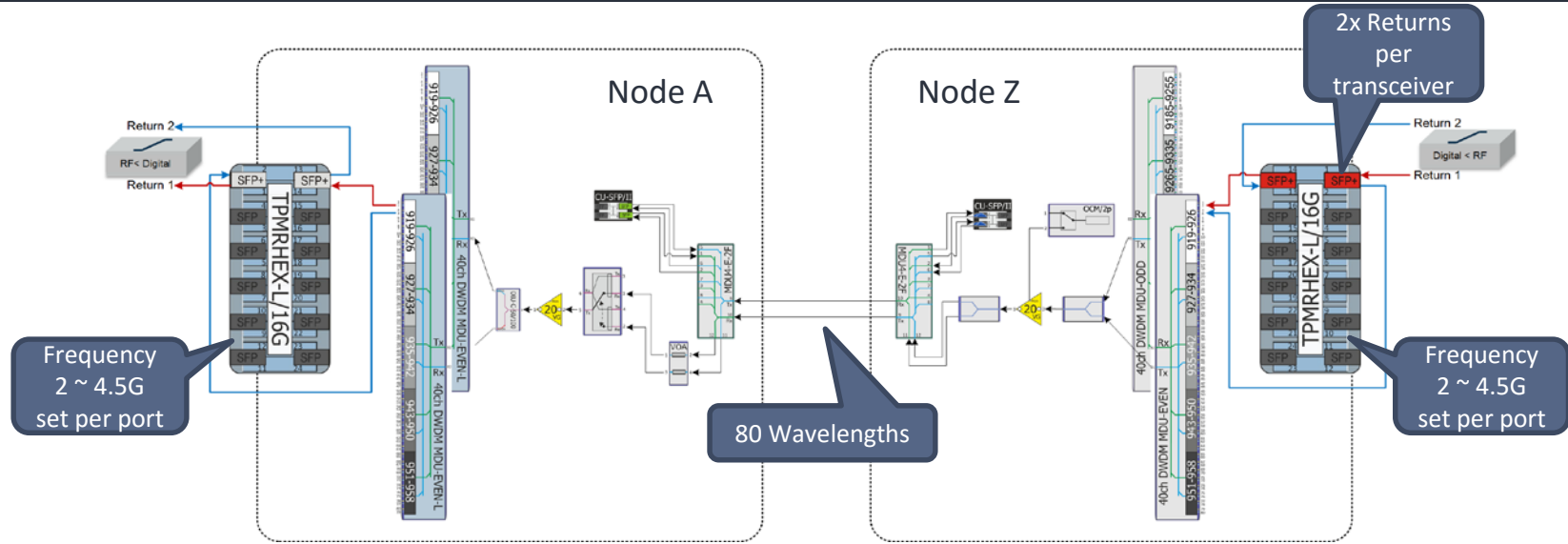

Digital Node Return

- Accommodates 80 wavelengths per fiber for Uni-directional transport
- Provides power balancing and optical power monitoring for all wavelengths
- Fiber Protection Unit provide LO switching for alternate fiber paths
- Optical power budget to the Node is greatly improved with the use of Transponders

Basics of Optical Transport – Metro Networks

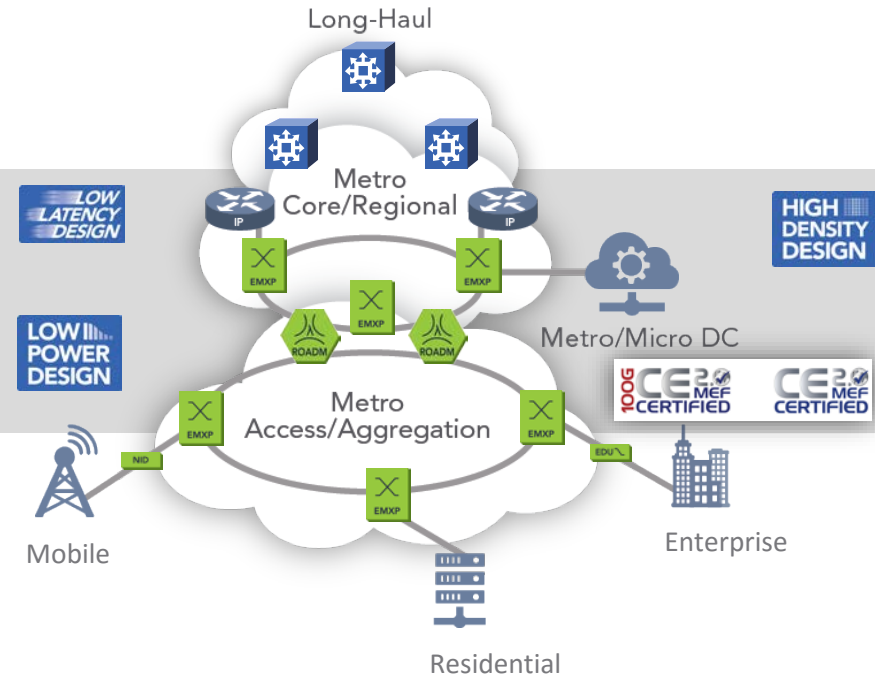

- ▶ Typically comprised of P2P, Ring, & Mesh physical topologies
- ▶ Transport distances are usually range from 10s to 1500 km
- ▶ The longer distance require amplification so DWDM is typically used to maximize fiber utilization for the services provided
- ▶ Aggregation and switching of sub-rate signals is utilized to create an efficient transport network

Basics of Optical Transport – Metro Application, Example

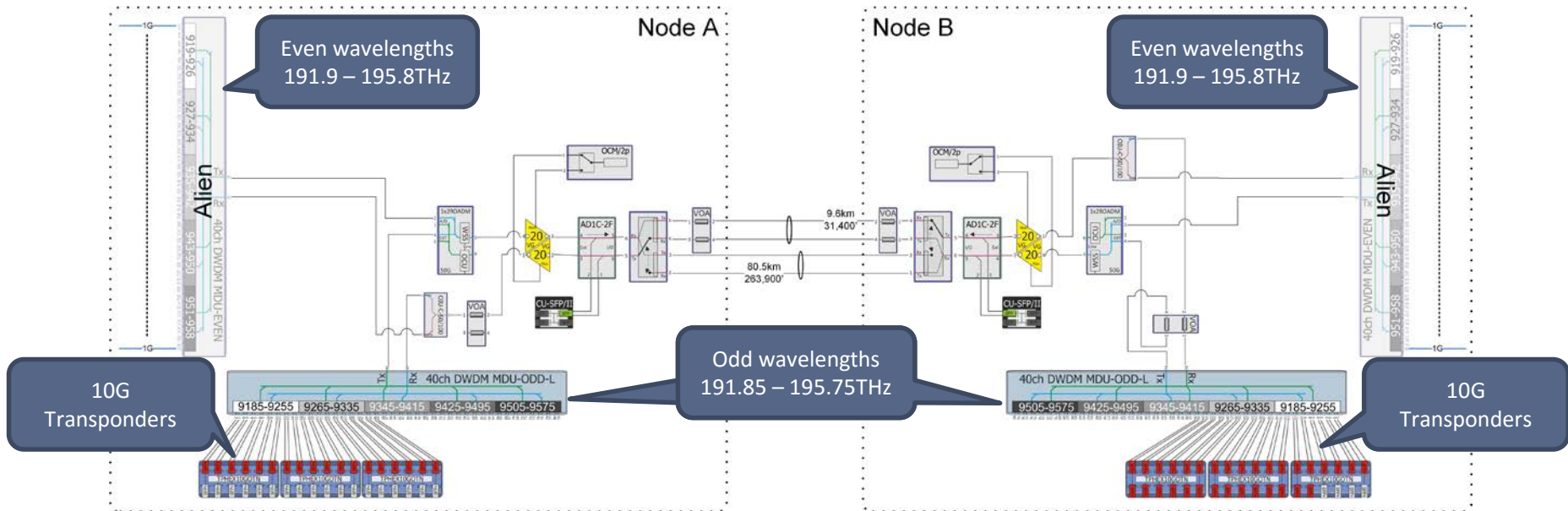

Metro Transport Application

- Accommodates the existing wavelengths combined with additional 40 wavelengths
- Provides power balancing and optical power monitoring for all wavelengths
- Fiber Protection Unit provide LO switching for alternate fiber paths
- Optical power budget to the CPE is greatly improved with the use of Transponders

Basics of Optical Transport – Data Center Interconnect

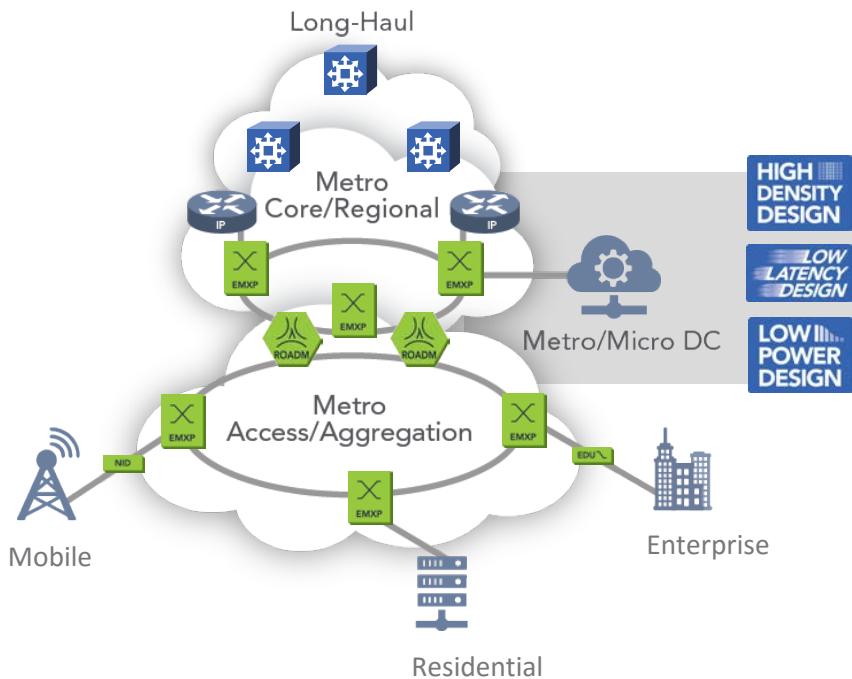

- ▶ A “special case”
 - Special case of Metro
 - Special case of Long Haul
- ▶ Point to point, high capacity connectivity...
 - Lowest cost per bit
 - Low power and high density
 - Operational simplicity

Basics of Optical Transport – Long Haul Networks

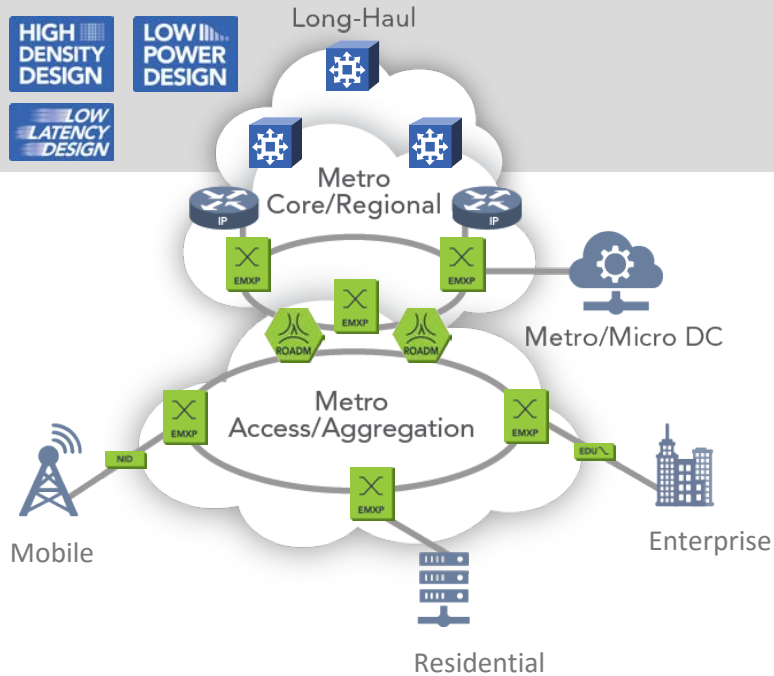

- ▶ Typically comprised of P2P & Ring topologies
- ▶ Transport distances are usually 1000s of km
- ▶ Amplification and DWDM are used throughout this portion of the network
- ▶ Capacity and reach are critical components of these network segments
- ▶ Switching technologies like OTN, Ethernet, & MPLS improve the bandwidth capacities to maximize the efficiency of the transport network

Optical Transport – Infinera End-to-End Portfolio

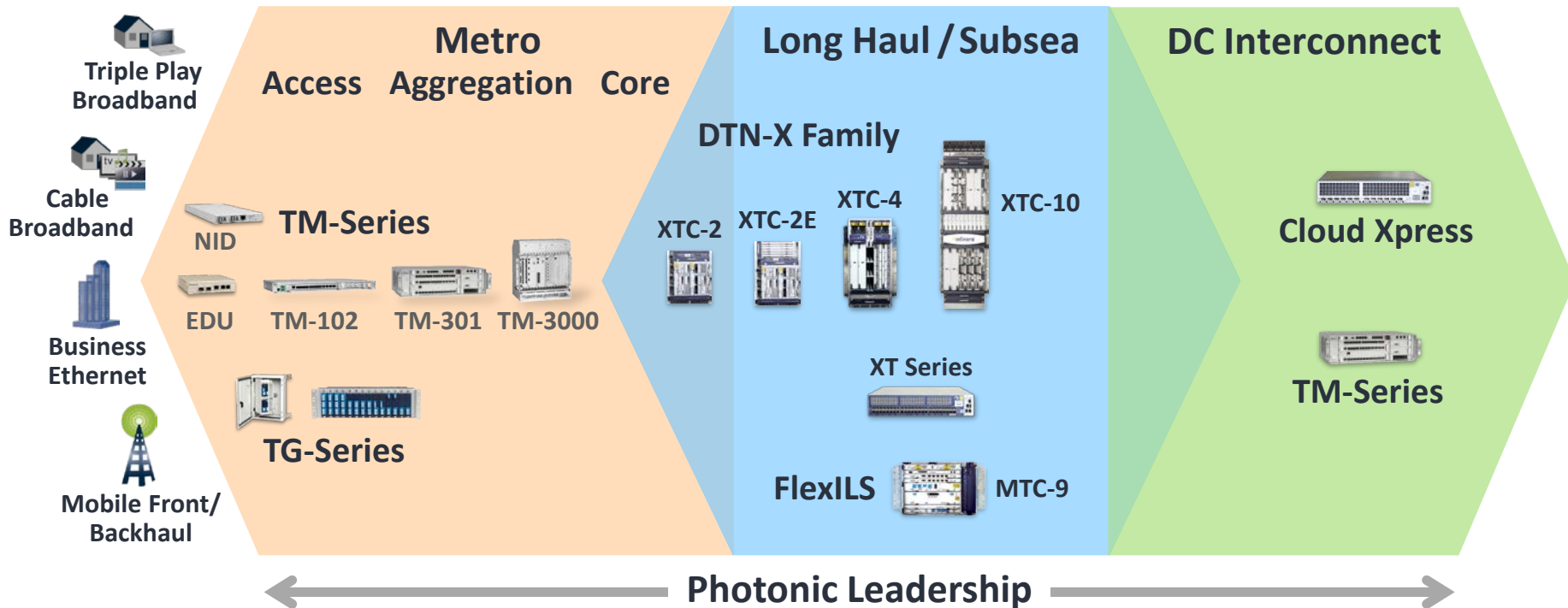

Thank You!

