

# Operation Manual

Manual de Usuario

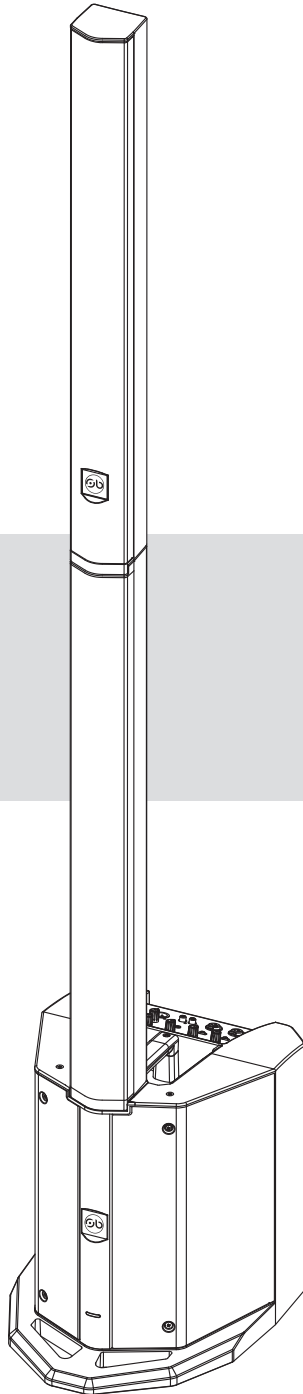

## CONCIERTO 500 PORTABLE LINE ARRAY SYSTEM

VER. 1.0

## Explanation of Graphical Symbols



The lightning flash with arrowhead symbol within an equilateral triangle is intended to alert the user to the presence of uninsulated 'dangerous voltage' within the product's enclosure that may be of sufficient magnitude to constitute a risk of electric shock to persons.



The exclamation point within an equilateral triangle is intended to alert the user to the presence of important operating and maintenance (servicing) instructions in the literature accompanying the product.

	<b>CAUTION</b>	<b>VORSICHT</b>	
	<b>BEFORE OPENING PULL MAIN PLUG</b>	<b>VOR DEM OFFNEN NETZSTECKER ZIEHEN</b>	
<b>CAUTION:</b> TO REDUCE THE RISK OF FIRE REPLACE WITH ONLY SAME TYPE AND RATING OF FUSE			
<b>WARNING:</b> TO REDUCE THE RISK OF FIRE OR ELECTRICS DO NOT EXPOSE THIS APPLIANCE TO RAIN OR MOISTURE.			

## IMPORTANT SAFETY INSTRUCTIONS

- 1 Read these instructions.
- 2 Keep these instructions.
- 3 Heed all warnings.
- 4 Follow all instructions.
- 5 Do not use this apparatus near water.
- 6 Clean only with dry cloth.
- 7 Do not block any ventilation openings. Install in accordance with the manufacturer's instructions.
- 8 Do not install near any heat sources such as radiators, heat registers, stoves, or other apparatus (including amplifiers) that produce heat.
- 9 Do not defeat the safety purpose of the polarized or grounding-type plug. A polarized plug has two blades with one wider than the other. A grounding type plug has two blades and a third grounding prong. The wide blade or the third prong are provided for safety. If the provided plug does not fit into your outlet, consult an electrician for replacement of the obsolete outlet.
- 10 Protect the power cord from being walked on or pinched particularly at plugs, convenience receptacles, and the point where they exit from the apparatus.
- 11 Only use attachments/accessories specified by the manufacturer.
- 12 Use only with the cart, stand, tripod, bracket, or table specified by the manufacturer, or sold with the apparatus. When a cart is used, use caution when moving the cart/apparatus combination to avoid injury from tip-over.
- 13 Unplug this apparatus during lightning storms or when unused for long periods of time.
- 14 Refer all servicing to qualified service personnel. Servicing is required when the apparatus has been damaged in any way, such as power-supply cord or plug is damaged, liquid has been spilled or objects have fallen into the apparatus, the apparatus has been exposed to rain or moisture, does not operate normally, or has been dropped.



### WARNING

TO REDUCE THE RISK OF FIRE OR ELECTRIC SHOCK, DO NOT EXPOSE THIS APPARATUS TO RAIN OR MOISTURE.

## PRECAUTIONS

### PLEASE READ CAREFULLY BEFORE PROCEEDING

Please keep this manual in a safe place for future reference.

### WARNING

Always follow the basic precautions listed below to avoid the possibility of serious injury or even death from electrical shock, short-circuiting, damages, fire or other hazards. These precautions include, but are not limited to, the following:

#### Power supply/Power cord

- Only use the voltage specified as correct for the device. The required voltage is printed on the name plate of the device.
- Use only the included power cord.
- Do not place the power cord near heat sources such as heaters or radiators, do not excessively bend or otherwise damage the cord, place heavy objects on it, or place it in a position where anyone could walk on, trip over, or roll anything over it.

#### Do not open

- Do not open the device or attempt to disassemble the internal parts or modify them in any way. The device contains no user-serviceable parts. If it should appear to be malfunctioning, discontinue use immediately and have it inspected by qualified service personnel.
- Do not open the device or attempt to disassemble the internal parts or modify them in any way. The device contains no user-serviceable parts. If it should appear to be malfunctioning, discontinue use immediately and have it inspected by qualified service personnel.

#### Water warning

- Do not expose the device to rain, use it near water or in damp or wet conditions, or place containers on it containing liquids which might spill into any openings.
- Never insert or remove an electric plug with wet hands.

#### If you notice any abnormality

- If the power cord or plug becomes frayed or damaged, there is a sudden loss of sound during use of the device, or any unusual smells or smoke should appear, turn off the power switch, disconnect the electric plug from the outlet immediately, and have the device inspected by qualified service personnel.
- If this device is dropped or damaged, immediately turn off the power switch, disconnect the electric plug from the outlet, and have the device inspected by qualified service personnel.

## **WARNING**

Always follow the basic precautions listed below to avoid the possibility of physical injury to you or others, or damage to the device or other property. These precautions include, but are not limited to, the following:

### **Power supply/Power cord**

- Remove the electric plug from the outlet when the device is not to be used for extended periods of time, or during electrical storms.

When removing the electric plug from the device or an outlet, always hold the plug itself and not the cord. Pulling by the cord can damage it.

### **Location**

When transporting or moving the device, always use two or more people. Attempting to lift the device by yourself may damage your back, result in other injury, or cause damage to the device itself.

Before moving the device, remove all connected cables.

When setting up the device, make sure that the AC outlet you are using is easily accessible. If some trouble or malfunction occurs, immediately turn off the power switch and disconnect the plug from the outlet.

Do not use the device in a confined, poorly ventilated location. Make sure that there is adequate space between the mixer and surrounding walls or other devices: at least 1' ft. at the side, 1' ft. behind and 1' ft. above. If the mixer is to be used installed into the speaker cabinet, make sure to allow adequate space between the speaker and the surrounding walls or other devices: at least 1' ft. at the sides, 1' ft. behind and 1' ft. above. Inadequate ventilation can result in overheating, possibly causing damage to the device(s), or even fire.

Do not use the speaker's handles for suspended installation. Doing so could result in damage or personal injury.

Avoid setting all equalizer controls and faders to their maximum. Depending on the condition of the connected devices, doing so may cause feedback and may damage the speakers.

Do not expose the device to excessive dust or vibrations, or extreme cold or heat (such as in direct sunlight, near a heater, or in a car during the day) to prevent the possibility of panel disfiguration or damage to the internal components.

Do not place the device in an unstable position where it might accidentally fall over.

Do not block the vents. This mixer has ventilation holes at the top to prevent the internal temperature from becoming too high. In particular, do not place the device on its side or upside down. Inadequate ventilation can result in overheating, possibly causing damage to the device(s), or even fire.

Do not use the device in the vicinity of a TV, radio, stereo equipment, mobile phone, or other electric devices. Doing so may result in noise, both in the device itself and in the TV or radio next to it.

### **Connections**

- Before connecting the device to other devices, turn off the power for all devices. Before turning the power on or off for all devices, set all volume levels to minimum.

For the SPEAKERS jacks, Use only the included speakers and speaker cables. Use of other types of speakers and cables may result in damage to the device(s), or even fire.

### **Handling Precautions**

When turning on the AC power in your audio system, always turn on the device LAST, to avoid speaker damage. When turning the power off, the device should be turned off FIRST for the same reason.

Do not insert your fingers or hands in any gaps or openings on the device (vents, ports, etc.).

Avoid inserting or dropping foreign objects (paper, plastic, metal, etc.) into any gaps or openings on the device (vents, ports, etc.). If this happens, turn off the power immediately and unplug the power cord from the AC outlet. Then have the device inspected by qualified service personnel.

Do not use the device for a long period of time at a high or uncomfortable volume level, since this can cause permanent hearing loss. If you experience any hearing loss or ringing in the ears, consult a physician immediately.

Do not operate the device if the sound is distorting. Prolonged use in this condition could cause overheating and result in fire.

Do not rest your weight on the device or place heavy objects on it, and avoid use excessive force on the buttons, switches or connectors.

### **Protective Circuit (poly switch)**

All full-range loudspeakers are fitted with a self-resetting poly switch that protects the high-frequency driver from damage caused by excessive power. If a loudspeaker cabinet loses high-frequency output, immediately remove power from the unit and wait for two to three minutes. This should be long enough to allow the poly switch to reset. Reapply power and check the performance of the high frequency driver before continuing, with the power reduced to a level that does not cause the poly switch to interrupt the signal.

### **Interference From Cell Phone**

Using a cell phone near the speaker system can induce noise. If this occurs, move the cell phone further away from the speaker system. Air blowing out of the bass reflex ports is normal, and often occurs when the speaker is handling program material with heavy bass content.

The manufacturer will not be responsible for damage caused by improper use or modification to the device.

Always turn the power off when the device is not in use. The performance of components with moving contacts, such as switches, volume controls, and connectors, deteriorates over time. Consult qualified service personnel about replacing defective parts.

**Product overview**

The CONCIERTO 500 Portable Line Array System is shipped in two cartons. Carefully unpack the cartons and check that you have all the items listed on this page.

**WARNING:** To avoid danger of suffocation, keep the plastic bags out of the reach of children.

The CONCIERTO 500 system consists of:

- CONCIERTO 500 Power Stand
- CONCIERTO 500 Extensions

The CONCIERTO 500 system comes with a slipcover for the Power Stand and a padded carry bag for the CONCIERTO 500 Extensions.

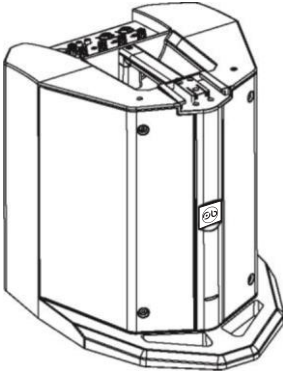
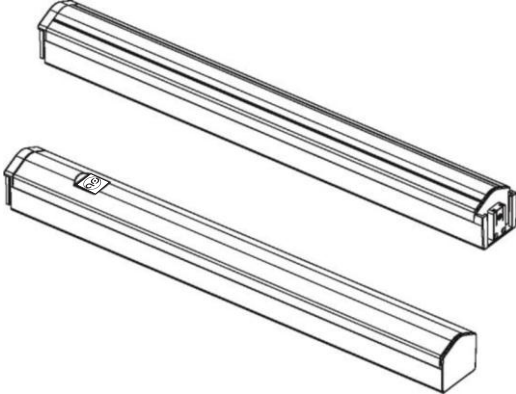
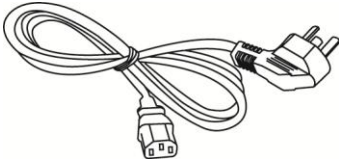
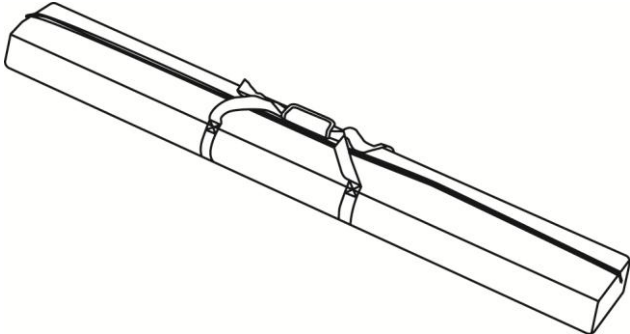
Power stand carton	Extensions carton
	
	

## System configurations

You can set up the versatile CONCIERTO 500 system in two unique positions. The examples below will help you quickly identify the position that can work best for you.

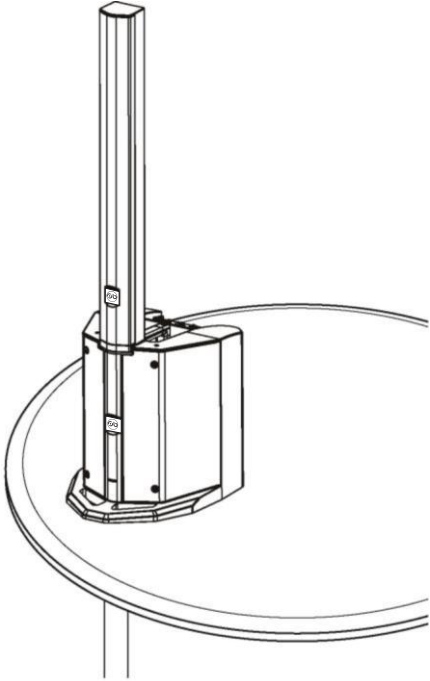
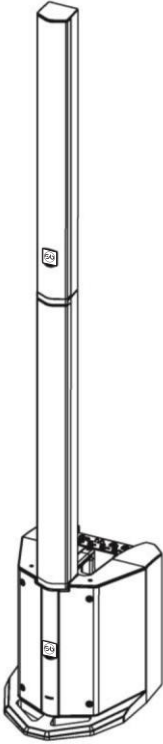
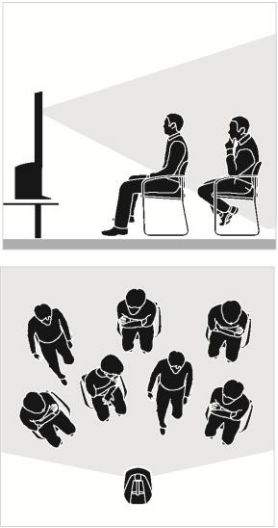
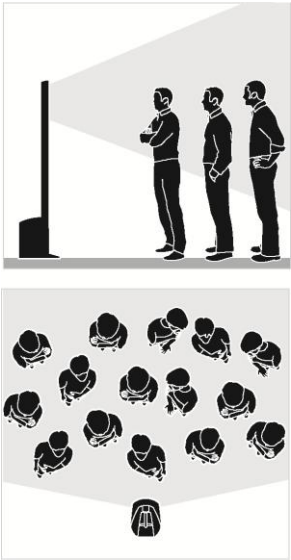
<p><b>Collapsed position</b></p> 	<p><b>Extended position</b></p> 
<p><b>Smaller audiences</b></p> <ul style="list-style-type: none"><li>• Intimate acoustic performances</li><li>• Music playback</li><li>• Presentations</li><li>• Speeches</li></ul>	<p><b>Larger audiences</b></p> <ul style="list-style-type: none"><li>• Musical performances auditorium/coffeehouse</li><li>• DJ events</li><li>• Announcements larger spaces</li></ul>
<p>The CONCIERTO 500 Compact Extensions are not required when using the CONCIERTO 500 Portable Line Array System in the collapsed position. They are included for situations where you need to elevate the Loudspeaker Array to project sound to larger audiences.</p>	
	

### ***Setting up the system***

Before making any connections, you should set the CONCIERTO 500 Portable Line Array System up either in the collapsed position (the system is shipped in the collapsed position) or the extended position.

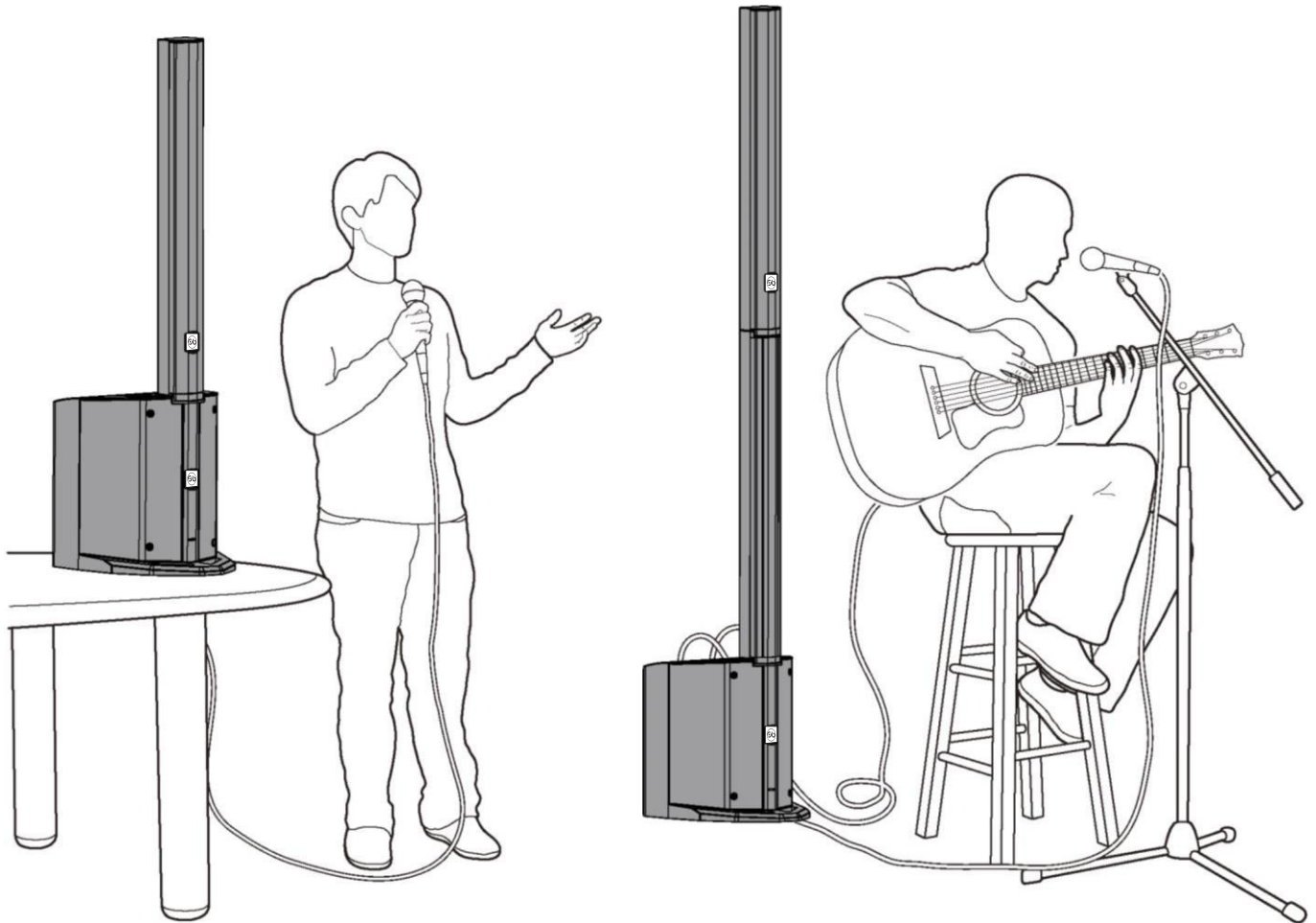

### ***Setting up in the collapsed position***

To get the most sound quality and ensure that seated audience members enjoy the full frequency range of the system, position it on a table (shown above) at ear-level or at the front edge of a stage (not shown). This will allow sound to project clearly and evenly throughout the audience.

### ***Setting up in the extended position***

In larger rooms, or with larger audiences where the sound could be blocked by obstacles, it is best to set up the CONCIERTO 500 Portable Line Array System in the extended position.

# Specifications

<b>CONCIERTO 500</b>	
<b>Amplifier</b>	
Inputs	XLR/TRS combo jack stereo RCA & 1/8" AUX input
Outputs	XLR balanced line output
Power output	RMS 250W / PEAK 1000W
Volume	volume control each channel, 2 band EQ
Power input	100-240V ~50/60 Hz switchable
Features	class D amplifier and switching power design power / clip indicator Excellent compressor
<b>Subwoofer</b>	<b>active vented subwoofer</b>
Frequency response	55-200 Hz
Max output spl	114dB (at max amp output)
Driver	8" subwoofer, 1.5" vc 33ohm (CONCIERTO 500SW8)
Cabinet	PP plastic
Grill	1.0mm steel
<b>Satellite</b>	<b>passive full-range speaker</b>
Frequency response	180-20K Hz
Max output spl	114dB
Impedance	4 ohms
Driver	6*2.75" full range line array
Cabinet	ABS plastic
Grill	1.0mm steel
MEAS / G.W.	11*20*85.5CM/1PC/5KG(SAT) 50.5*40*50.5CM/1PC/13KG (SUB)

## **BLUETOOTH FUNCTION INSTRUCTIONS**

### Bluetooth LED Indicator

1. If Light is OFF: The Bluetooth is disconnected
2. If Light is blinking steadily: The Bluetooth is ready for pairing.
3. If Light is Blinking Quickly: The Bluetooth is ready for pairing.
4. If Light is on and not blinking: The Bluetooth is connected

### Bluetooth Control

1. Please switch Channel 3 switch to BT (Bluetooth)
2. Make sure that the device to be synced is turned on and ready to be connected via Bluetooth.
3. Press the button with Bluetooth Symbol for pairing mode (the LED indicator will blink quickly)
4. You may now pair any Bluetooth audio enabled device (LED will be solid Blue)
5. To disconnect Bluetooth, press the Bluetooth button again.



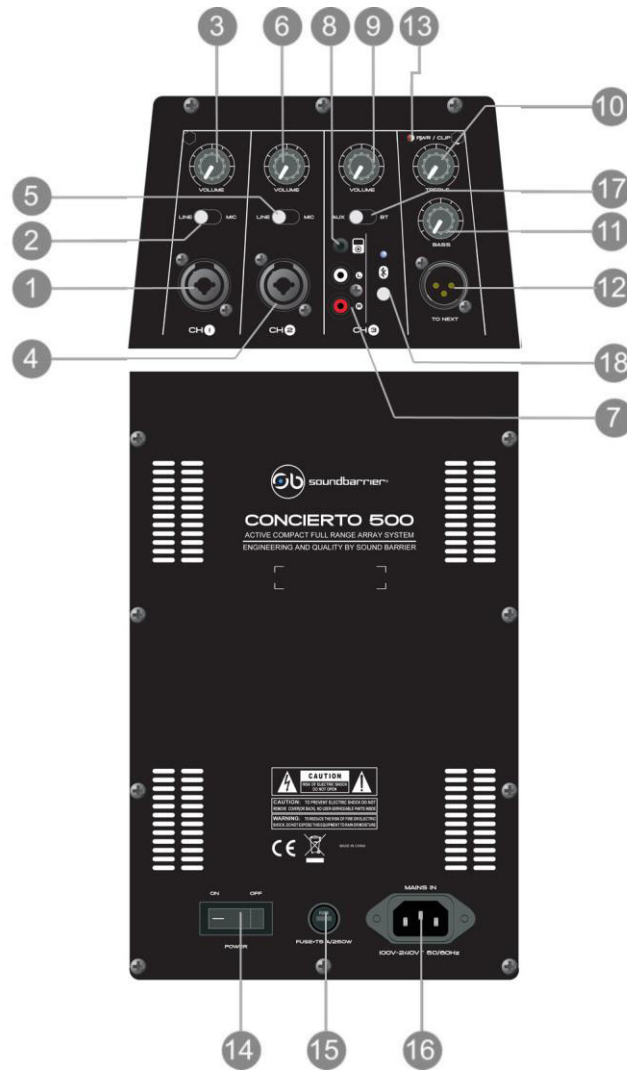

## CONTROLS AND FUNCTIONS:

1. Combo input:balance input, accepts “XLR\ 1/4”TRS” sockets
2. LINE/MIC selector
3. Input level control for CH1
4. Combo input:balance input, accepts “XLR\ 1/4”TRS” sockets
5. LINE/MIC selector
6. Input level control for CH2
7. RCA Input: RCA Stereo Input
8. 1/8” input: stereo unbalance signal
9. Input level control for CH3
10. Treble control : This potentiometer sets the HIGH TONE level,if rotated clockwise it enhances the highs, if rotated counter-clockwise it reduces the highs (in the centre position the response is flat).
11. Bass control :This potentiometer sets the LOW TONE level: if rotated clockwise it enhances the lows, if rotated counter-clockwise it reduces the lows (in the centre position the response is flat).
12. LINEOUT: XLR mixer output for NEXT PA system.
13. Power/Clip indicator -Displays the input signal status in color:Green: power ON,Red: Input signal clipping.
14. Power switch: This switch can be used to switch the diffuser on and off.
15. Fuse holder: Only replace the fuse when the device is disconnected from mains. Only use fuse of the same rating and power, The correct fuse is specified on the rear panel.
16. Power input: Plug in the supplied power cable here.
17. BLUETOOTH and AUX (Dual RCA and Mini Plug) switch
18. BLUETOOTH Activation Switch and LED Indicator

# System Troubleshooting

<b>Mixer and Amplifier Will Not Turn On</b>
Is the included power cord correctly connected to a power outlet?
<b>Amplifier Turns Off Suddenly</b>
Is the vent on the top panel of the mixer blocked? Since inadequate ventage will cause the mixer to overheat, turn off the mixer and uncover the vents to allow the mixer & amplifier to cool. After a few minutes, the mixer should reset itself and can return to normal playback.
Is the POWER limiter flashing continuously? If the POWER limiter is flashing, the amplifier is being used beyond its design capabilities. Turn off and on and resume playback.
<b>No Sound From the Speaker(s)</b>
Are external instruments (including a microphone) or speakers correctly connected to the mixer?
Are the LEVEL controls of all relevant channels and/or the MASTER LEVEL control set to appropriate levels?
Are the SPEAKERS L/R jacks connected to the included speakers? If there is still no sound, contact qualified service personnel.
<b>Distortion or Noise in the Audio Signal</b>
Are the LEVEL controls of all relevant channels and/or the MASTER LEVEL control set to appropriate levels?
Are the MIC/LINE switches of each channels set appropriately?
Are both XLR type and phono type jacks on channels 1-4 being used (connected) at the same time? XLR and phono inputs can not be used simultaneously. Is the input signal from the connected device set to an appropriate level?
<b>Output Level is Low</b>
Are the LEVEL controls of all relevant channels and/or the MASTER LEVEL control set to appropriate levels?
Are the MIC/LINE switches of each channels set appropriately?
Are both XLR type and phone type jacks on channels 1-4 being used (connected) at the same time? XLR and phono inputs can not be used simultaneously.
Is the input signal from the connected device set to an appropriate level?
<b>Sound Level is Powerful During Voice Announcements</b>
Are the Equalizer controls (HIGH/LOW) set to appropriate level?



