

Description

The STRATUS 15H is compact two-way weather resistant high SPL loudspeaker that is ideal for stadiums, sports facilities, waterparks, and other outdoor venues. The body is manufactured with plastic injection molding and conforms to IP56 international standards. The horn-loaded design includes 15" low-frequency and 1.4" exit high-frequency drivers for years of power and clarity in fixed installations.



Complete Protection from any tools or objects (dust permitted - no harmful deposits).

This enclosure is not air tight and therefore only allows dust size particles in non-harmful quantities to penetrate.

High pressure jets from all directions. (limited ingress permitted).

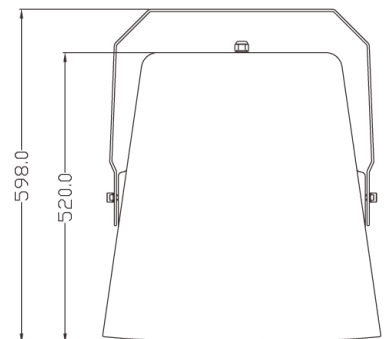
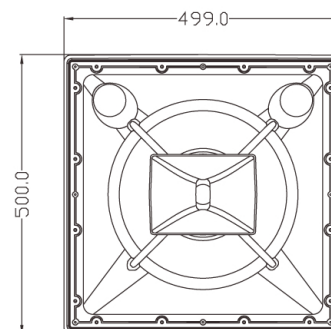

Specifications

	STRATUS 15H	STRATUS 15HT
Model	STRATUS 15H	STRATUS 15HT
Frequency Response (-3dB)	50Hz-18kHz	50Hz-18kHz
Frequency Response (-10dB)	45-20kHz	45-20kHz
Drivers	(LF) 1 x 15", 3" VC (HF) 1 x 1.4" Exit, 3" VC	(LF) 1 x 15", 3" VC (HF) 1 x 1.4" Exit, 3" VC
Input Voltage	----	100V
Rated Power	600W RMS, 2400 PEAK	125W/250W/500W/OFF/8Ω 600W RMS
Sensitivity	103dB 1W/1M	103dB 1W/1M
Maximum SPL	129dB Continuous, 135dB Peak	129dB Continuous, 135dB Peak
Impedance	8 Ohm Impedance	8 Ohm Impedance
Dispersion (-6dB)	70° (Horizontal) x 40° (Vertical)	70° (Horizontal) x 40° (Vertical)
Crossover Frequencies	1.5kHz Passive	1.5kHz Passive
Input Connectors	Covered Barrier Strip Terminals	Covered Barrier Strip Terminals
Dimensions	499mm (Width) x 500 (Height) x 520 (Depth)	499mm (Width) x 500 (Height) x 520 (Depth)
Weight.	63 lbs (28.5 kg)	68 lbs (31 kg)