



SMI Home

solutions









SMI Home

solutions





mocha



Simple solutions for all parts of your home

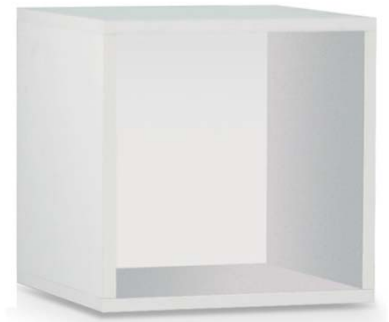

blanc



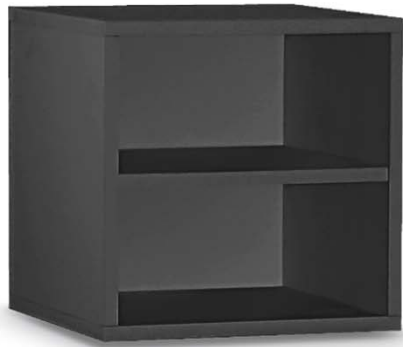

charcoal





walnut



noir



Full office applications





Mail and paper sorting application



Leg options available



Complete desk organization solution



6 Cube Organizer



9 Cube Organizer



8 Cube Organizer



Mini Off-set Organizer



Mini 6 Cube Organizer

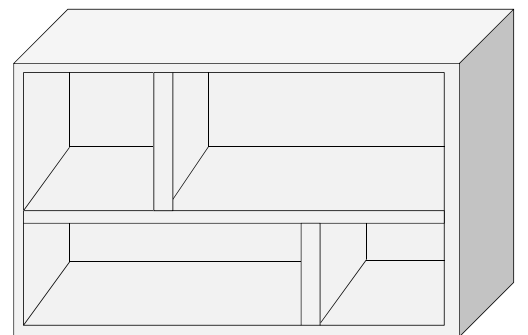
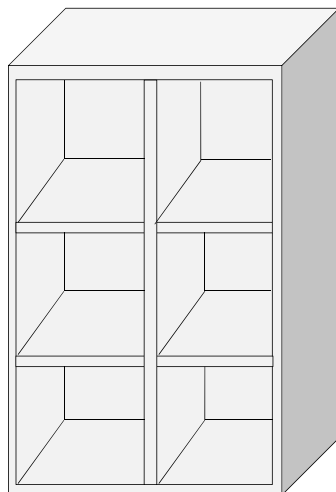
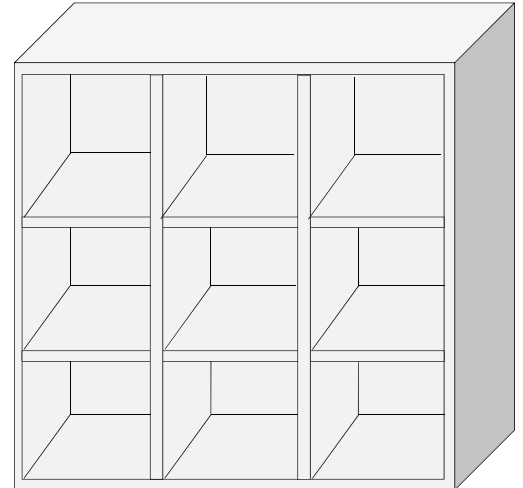
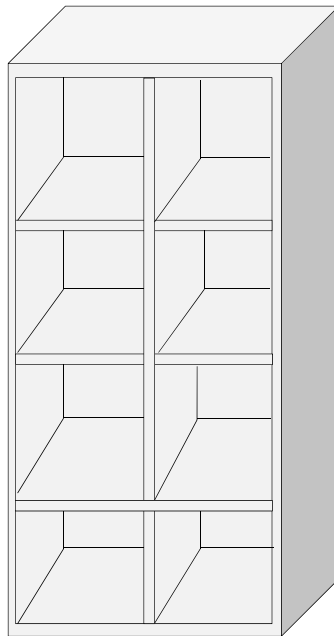
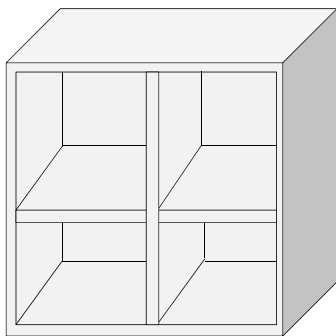
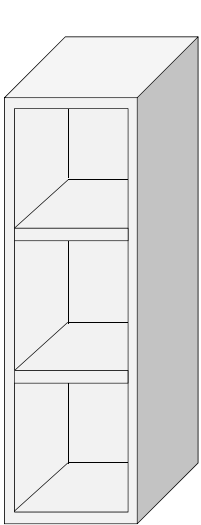

3 Cube Organizer and Mini 3 Cube Organizer





Modular project center



White



Honey Oak



Black

COMPONENT DIMENSIONS

PROJECT CENTER TABLE TOP
 2½" H x 55" W x 41" D
 Model # 1146

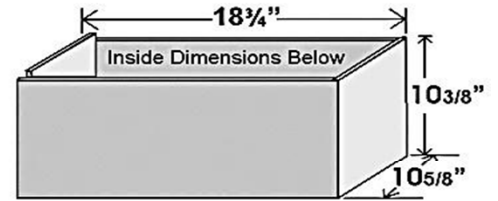
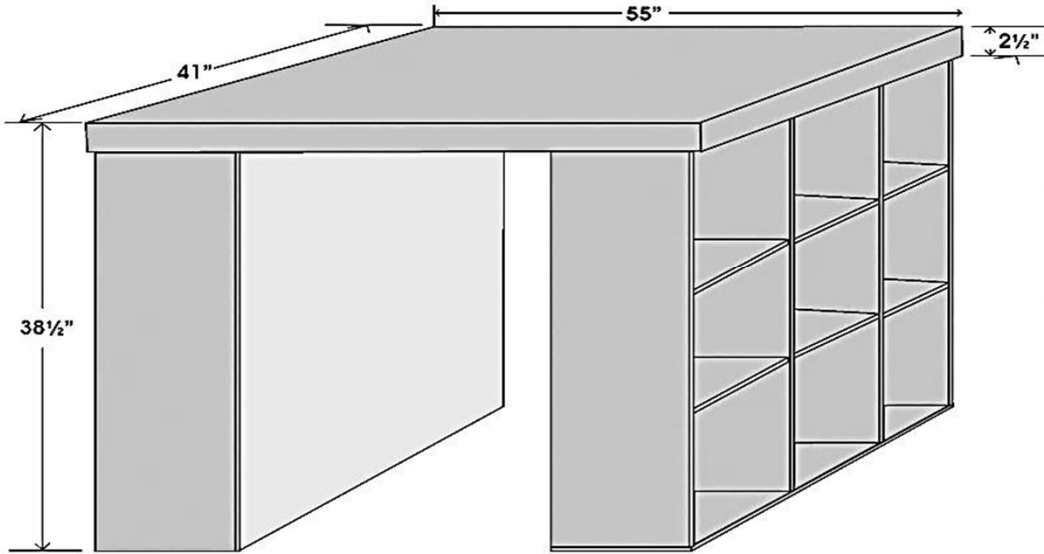

PROJECT CENTER DRAWERS
 (Optional Purchase)
 3 Drawers Per Set
 Inside: 10" H x 10" W x 17¾" D
 Model # 1147

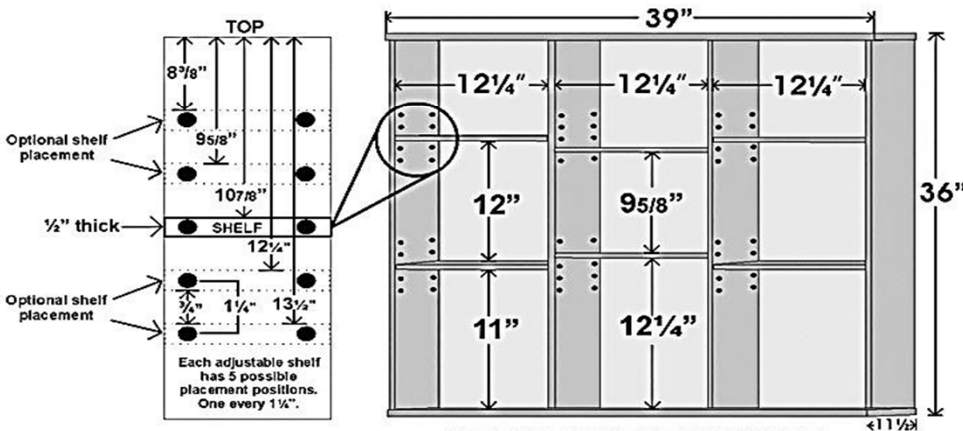

PROJECT CENTER BOOKCASE
 With 6 Adjustable Shelves
 36" H x 39" W x 11½" D
 Model # 1143

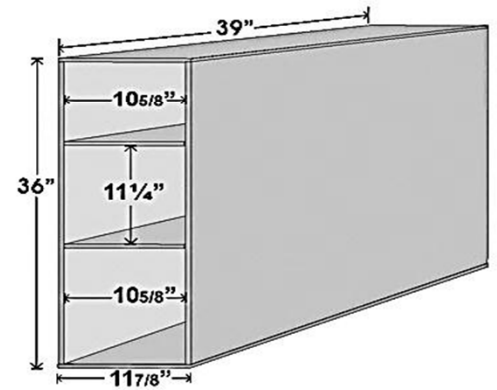

PROJECT CENTER BINS
 With 3 Fixed Shelves
 36" H x 11½" W x 39" D
 Open Both Ends
 Model # 1145



Junior

SMI Home





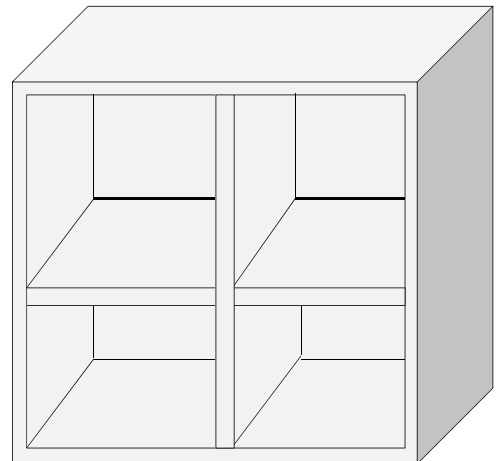
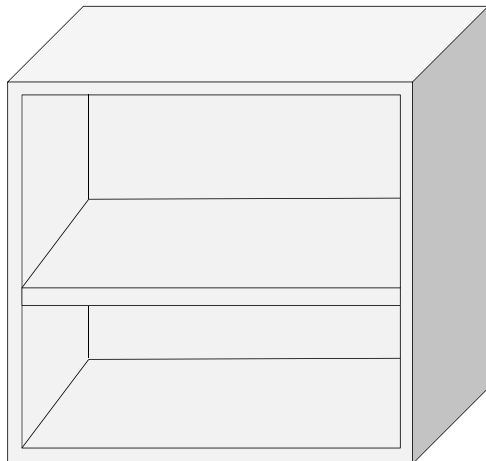



color basket series



color basket series





Cubic playroom





Single Toy Bin



Storage Cabinet



Double Toy Bin

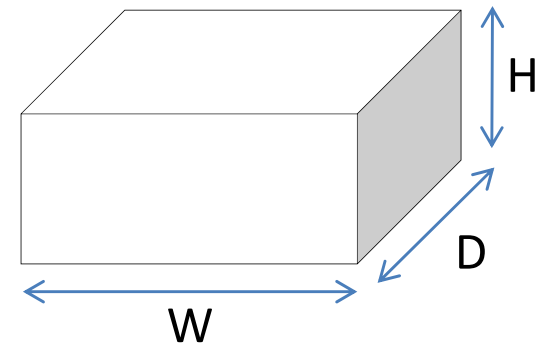
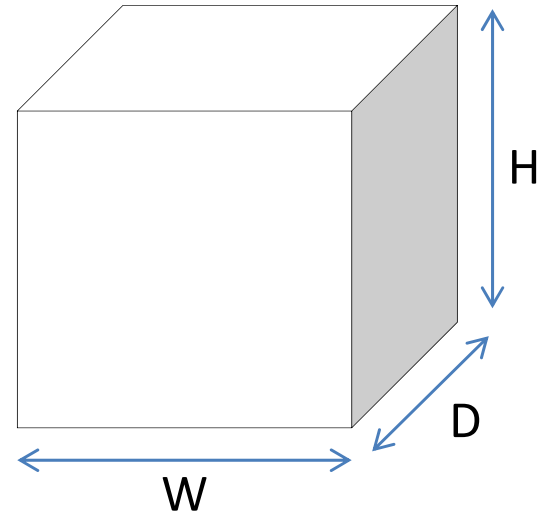

Description	Size W x D x H cm
38cm	35 x 35 x 35
38cm half size	35 x 35 x 26
15cm	13 x 13 x 13
15cm half size	13 x 13 x 5.5
Customized sizes available upon request	

Basic colors	
	White
	Black
	Blue
	Green
	Red
	Brown
Customized color available upon request	

FAQ

Q: What is E-1 particle board standard?

A: E-1 standard is the German environmental law for formaldehyde emissions from particle board to not exceed .01 parts per million. E-1 standard is the strictest in the world, it meets requirements to all markets.

Q: Why is there formaldehyde in the products?

A: Under normal conditions, formaldehyde is a colorless gas with a pungent smell. It occurs naturally in all living cells and therefore also in the human body. Formaldehyde is able to combine with a number of substances to form a variety of end-products, and synthetically manufactured formaldehyde is used in the manufacture of paints, lacquers, adhesives, rigid plastics and a number of toiletry items, such as shampoo and soap. Formaldehyde is normally used in bound form or in aqueous solution as formalin. Formaldehyde also occurs as a by-product of incomplete combustion, for example in car exhaust fumes and tobacco smoke where it is present in much higher concentrations than emitted from, for example, furniture.

Formaldehyde is quickly broken down in nature and is not accumulated in animals and plants. Formaldehyde can, however, cause allergic reactions in contact with skin or if inhaled. In high doses over a long period of exposure, formaldehyde is carcinogenic.

Q: Why does SMI-Home only produce products with E-1 or higher quality standards?

A: SMI-Home focuses on E-1 and higher standard products mainly due to keeping competitiveness in the market.

We purchase mainly E-1 standard boards in high quantity from our supplier(s) so that we can keep the cost low for this raw material. If we were to purchase multiple board standards, the volume purchase will no longer exist since our suppliers offer discount based on quantity per quality level.

Another reason would be our production line efficiency. E-2 level and below boards contain an abundance of waste material other than wood particles, some of which are metallic; which will wear our cutting equipment down at a tremendous rate. The time and cost of exchanging a new saw blade will greatly affect the cost of the final product.

Finally from a safety aspect, by meeting this standard, our workers are less likely to be exposed to poisonous dust particles. Which puts us in the market as one of the top employers for worker safety in our field. We are working to further grow our business therefore having a skilled and reliable workforce is absolute necessary.

Q: Why is it so important to have a good seal on the surface and edge of the particle board products.

A: Particle boards in general are very susceptible to moisture. Exposure to humidity will cause the boards to expand and weaken. If the surface and the edge of the boards are sealed properly, this will greatly reduce the level of moisture from entering the raw particle board which in turn will prolong the life of the product.. As a second advantage to having a good seal, hazardous gas, though at minimal, can be sealed.

SMI-Home is a huge producer of edgings and laminated boards. We are able to control the quality of the products early in the early stage of production. Our finished products are raw materials for many cabinet producing factories.