

IKO's unique ideas and experiences are utilized to explore new world for special environment applications.

IKO Linear Way and Linear Roller Way are available for various special environment by using different materials and grease, surface treatment and dust protection measures, etc. Typical application fields and major countermeasures are described below.

Clean Environment

When the Linear Way or Linear Roller Way is used in clean environment such as a clean room, it is required that the environment is not polluted by dust-generation by the Linear Way or Linear Roller Way and it must have excellent rust prevention property as rust prevention oil cannot be used.

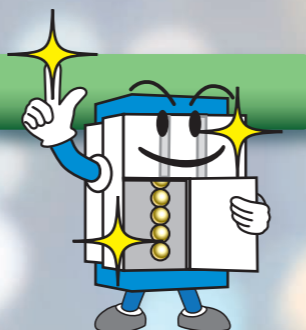

Vacuum Environment

When the Linear Way or Linear Roller Way is used in vacuum environment, it is required that the gas discharged from the Linear Way or Linear Roller Way does not pollute the environment or reduce the degree of vacuum, and it must have excellent rust prevention property as rust prevention oil cannot be used.



Heat Resistance Measures

When the Linear Way is used in an environment where temperature is higher than usual, heat resistance of synthetic resin components and metal parts will be an issue.



Dust Protection

If dust such as metal or wooden chips get into the way of the Linear Way or Linear Roller Way, reduction of life and accuracy may be caused. Therefore, measures to prevent foreign substances from entering into the way are necessary.



Spatter Protection

Spatter of welding, etc. is so hot that it adheres to components. Foreign substances adhering to the track rail firmly cannot be fully removed by normal dust protection measures, so measures to avoid adherence and enhanced foreign substances removal measures are necessary.

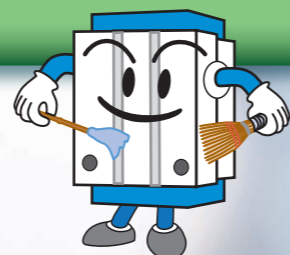

are utilized to explore new world for

Clean

- LCL Linear Way and Linear Roller Way
- Stainless Linear Way and Linear Roller Way
- Black chrome surface treatment
- Specified grease (CG2 or CGL grease)
- ◇ Fluorine grease

Corrosion resistance

- Hybrid C-Lube Linear Way L
- Non-magnetic stainless Linear Roller Way Super X
- Stainless Linear Way and Linear Roller Way
- Black chrome surface treatment

Vacuum

- LCL Linear Way and Linear Roller Way
- No end seal
- Stainless steel end plate
- ◇ Fluorine grease

Heat resistance

- Stainless steel end plate
- Special environment seal
- ◇ High temperature grease

Foreign substances (wood chips and metal powder, etc.)

- Linear Way H Ultra seal specification
- Track rail mounting from bottom
- Double end seals
- Scrapers
- C-Wiper
- Caps for rail mounting holes
- Rail cover plate for track rail
- Rail cover sheet
- Female threads for bellows
- Specific bellows

Spatter

- Scrapers
- Caps for rail mounting holes (aluminum alloy)
- Rail cover sheet
- Fluorine black chrome surface treatment
- Stainless steel end plate

- Linear motion rolling guide series for special environment :
Collective name of linear motion rolling guide series models corresponding to special environment.
- Special specification for special environment :
Special specification corresponding to special environment by combination of linear motion rolling guide series.
- ◇ Lubricant :
Lubricant suitable for each special environment can be selected.

LCL Linear Way and Linear Roller Way

Neither grease nor oil

World's first Liquid Crystal Lubricant

Liquid Crystal Lubricants are completely different from greases composed of base oils and thickeners. Liquid Crystal Lubricants are composed only of liquid crystal compounds, forming a new type of lubricant never seen before. Conventional grease base oils lubricate using dissimilar molecules, causing difficulties with adhesion to metal surfaces and evaporation. Liquid Crystal Lubricant forms molecular aggregates, improving adhesion to metal surfaces and minimizing evaporation. The Liquid Crystal Lubricant used in the LCL Linear Way and Linear Roller Way is the world's first Liquid Crystal Lubricant for bearings, achieving excellent lubrication functionality even under high contact pressure during rolling contact and successfully creating revolutionary new functions.

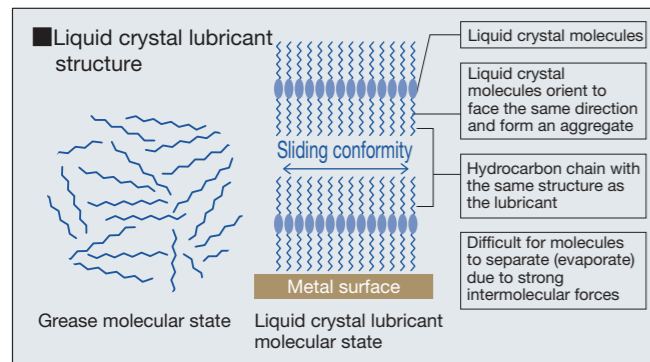
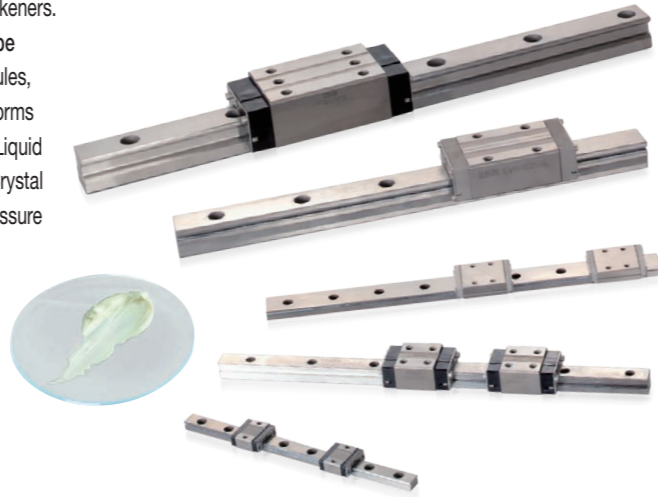

Features

Superior load durability

Long-term durability exceeds 40 times that of fluorine grease at room temperature and atmospheric pressure. 2 to 6 times greater durability than other types of grease, even in high-temperature environments.

Superior low dust-generation properties

Dust generation is less than 1/10 of lithium soap based grease.

Excellent outgas properties

The outgassing characteristics in high vacuum environments show excellent performance even even at high temperatures.

Minimizes lubricant evaporation

Zero mass loss even at 100°C. Liquid crystal lubricants have no loss due to evaporation.

Light and smooth sliding

The rolling resistance is lower than that of fluorine grease or lithium soap-based grease.

Performance

Load durability (room temperature)

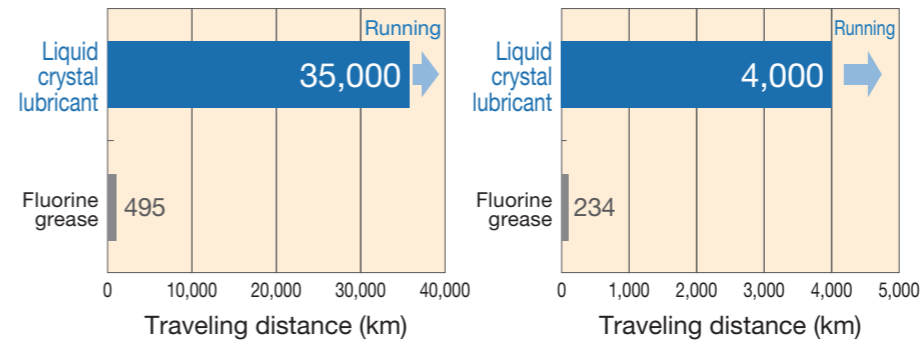

Test conditions ① Model number: LWL9...B Speed: 1m/s Load: 181N

Test conditions ② Model number: LRXD20SL Speed: 1m/s Load: 1150N

Load durability (high temperature)

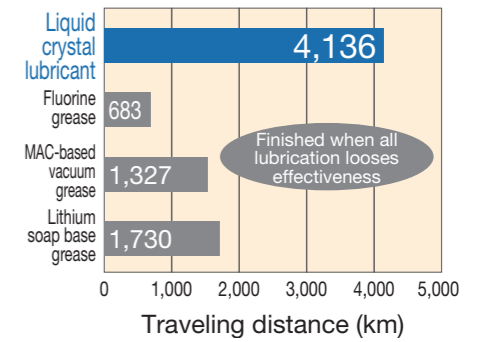

Test conditions Model number: LWLF18...B Speed: 1m/s Temperature: 120°C Load: 114N Evaluation: Traveling distance until lubrication failure

Outgas properties

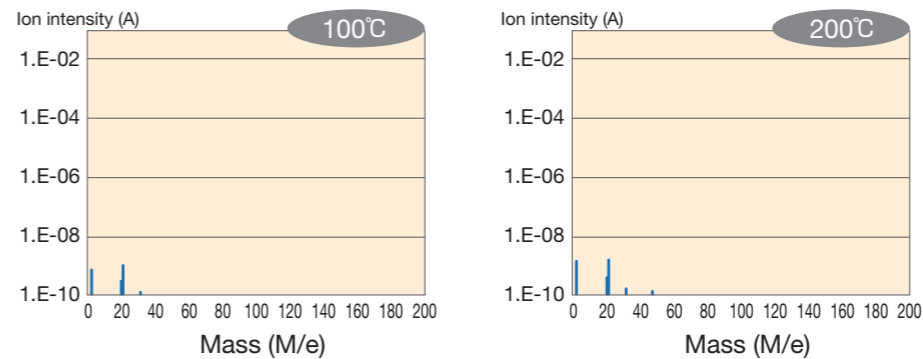

Measuring conditions Vacuum level: 10⁻⁵Pa Conditions: Liquid crystal lubricant only

Low dust-generation properties

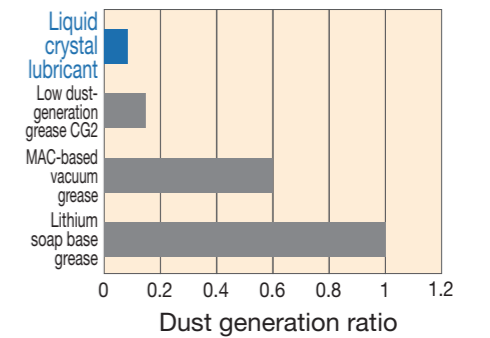

Test conditions Model number: LWL9...B/N Load: 80N Speed: 1m/s Evaluation time: 45 hrs Measured particle size: 0.5µm or more

Rolling resistance

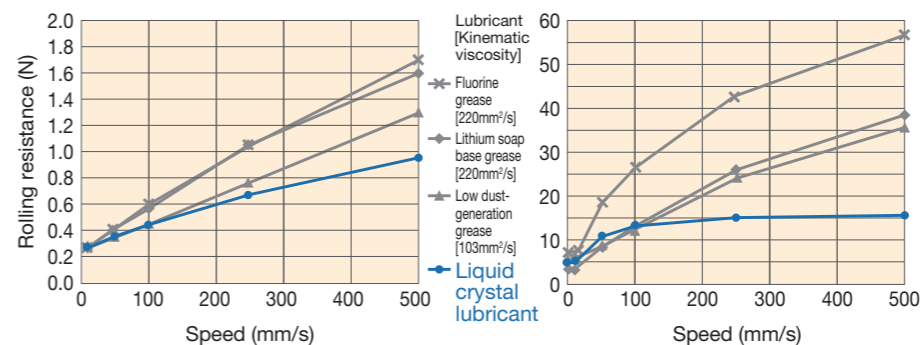

Test conditions Model number: LWL9...B/N

Test conditions Model number: LRXSG20

Evaporation characteristics

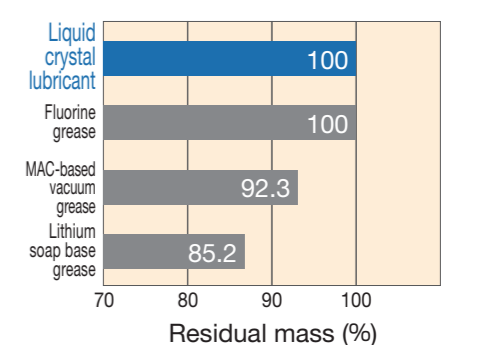

Test conditions Environment: Open atmosphere Temperature: 100°C Time: 770 hours

Applicable products

- Compatible series
- Linear Way L Series
 - Linear Way E Series
 - Linear Way H Series
 - Linear Way F Series
 - Linear Roller Way Super X Series

Remark 1. Applicable for stainless steel models from each series.
Remark 2. LCL Linear Ways and Linear Roller Ways are individually made to order. If needed, please contact IKO.

Hybrid C-Lube Linear Way ML

While maintenance free performance of C-Lube Linear Way ML is maintained, the silicon nitride ceramics ball improves high-speed performance and reduces noise level. Ceramics has more resistance to deformation and more rigidity than bearing steel and stainless steel.

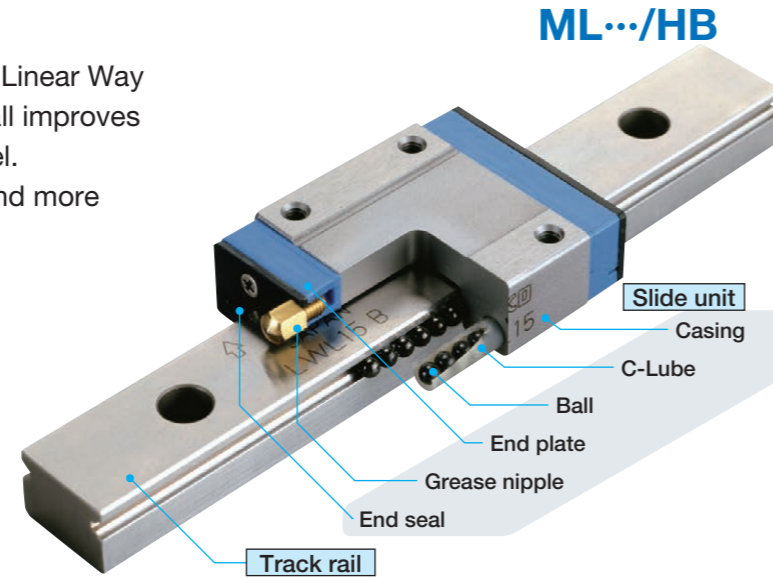

Standard specification	
Casing	Martensitic stainless steel
Track rail	Martensitic stainless steel
Ball	Silicon nitride ceramics
C-Lube	Capillary lubricating element (Porous resin)

Features

- Superior high-speed performance** ... More than three times durability
- Noise reduction** Noise reduction by about 4.5 dB
- High rigidity** Displacement volume reduced by about 10%
- Superior abrasion resistance** ... Preload reduction volume is about one fourth

※ All of the above based on comparison with our C-Lube Linear Way ML



Maintenance free
Achieved long term maintenance free

Eco-friendly
Minimized lubrication oil consumption

Compact
Integral lubrication parts

Smooth
Excellent sliding characteristic

Performance

More than three times durability

High-speed performance

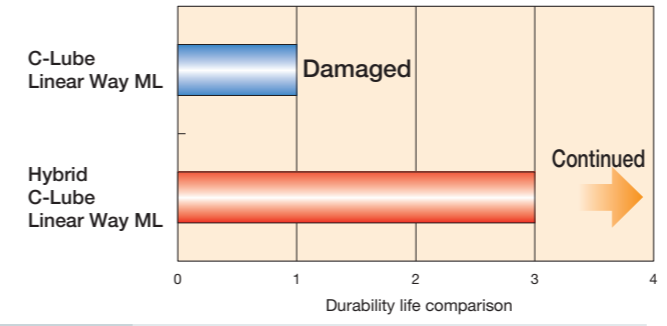

Test conditions Model : ML12 Velocity: 300 m/min Acceleration: 40 G

Noise reduction by about 4.5 dB

Low decibel

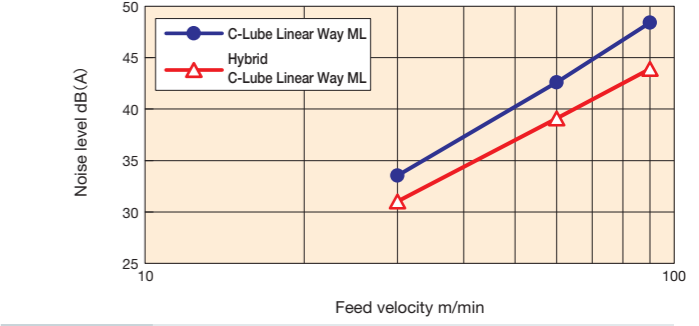

Test conditions Model : ML12 Measurement velocity: 30, 60, 90 m/min

Small deformation of rolling elements and excellent rigidity

High rigidity

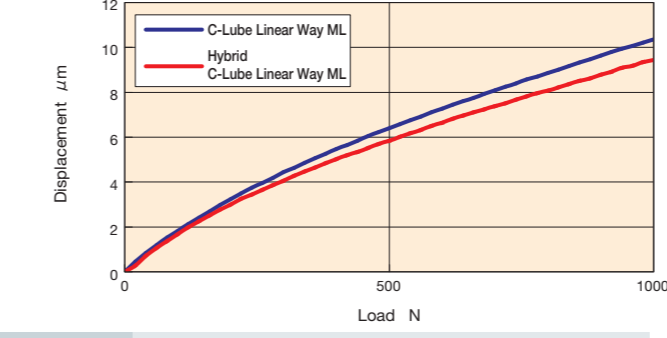

Test conditions Model : ML12 Preload: Standard Preload Load direction: Downward

Low preload reduction volume and accuracy maintained after operation

Abrasion resistance

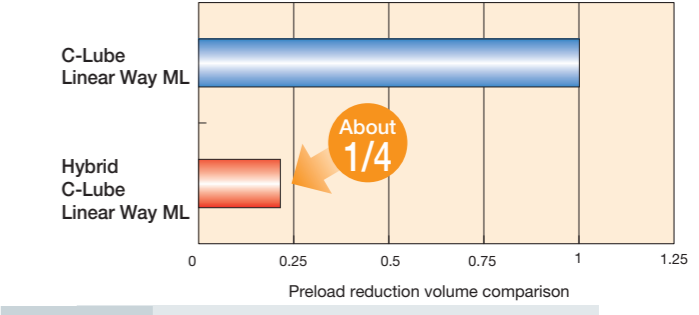

Test conditions Model : ML12 Velocity: 300 m/min Acceleration: 40 G Traveling distance: 13,000 km

Basic performance of C-Lube Linear Way

Achieved long term maintenance free

Maintenance free

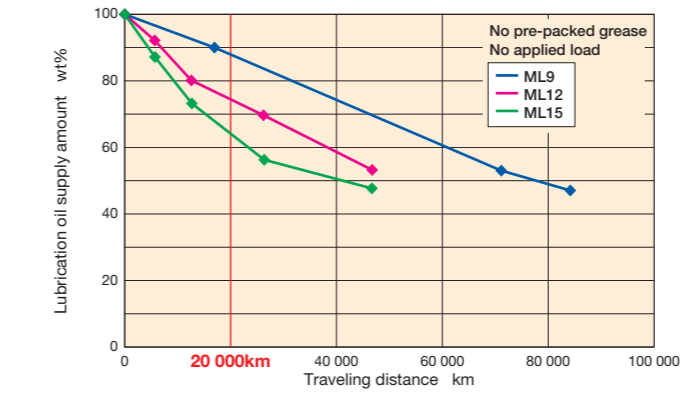

Achieved light and smooth sliding

Sliding characteristic

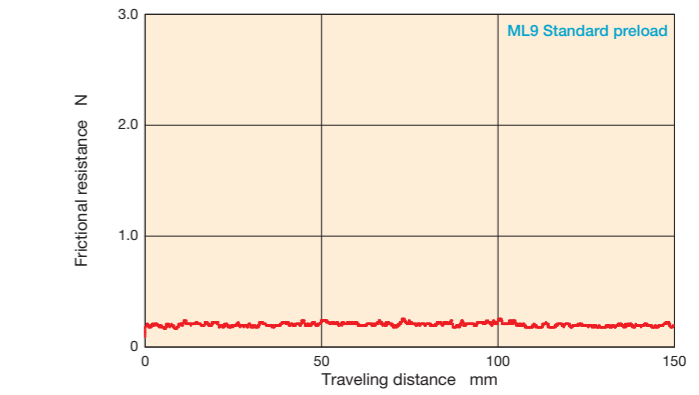

1N=0.102kgf=0.2248lbs.
1mm=0.03937inch

Non-magnetic stainless Linear Roller Way Super X

The non-magnetic stainless Linear Roller Way Super X is the world's first non-magnetic stainless steel endless motion roller type linear motion rolling guide to attain relative magnetic permeability of 1.01 or less. This is accomplished through the dedicated development of silicon nitride ceramic cylindrical rollers and non-magnetic stainless steel casings and track rails. Despite being non-magnetic material it still maintains the superior vibration characteristics, excellent running accuracy, and friction characteristics provided by the Linear Roller Way Super X. This allows for accurate and rapid positioning in environments affected by minimal magnetism.

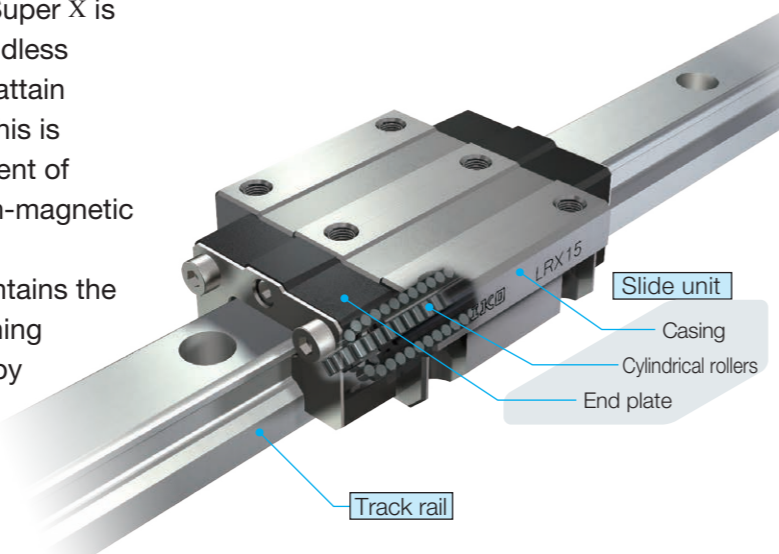

The world's first non-magnetic roller type with relative magnetic permeability of 1.01 or less

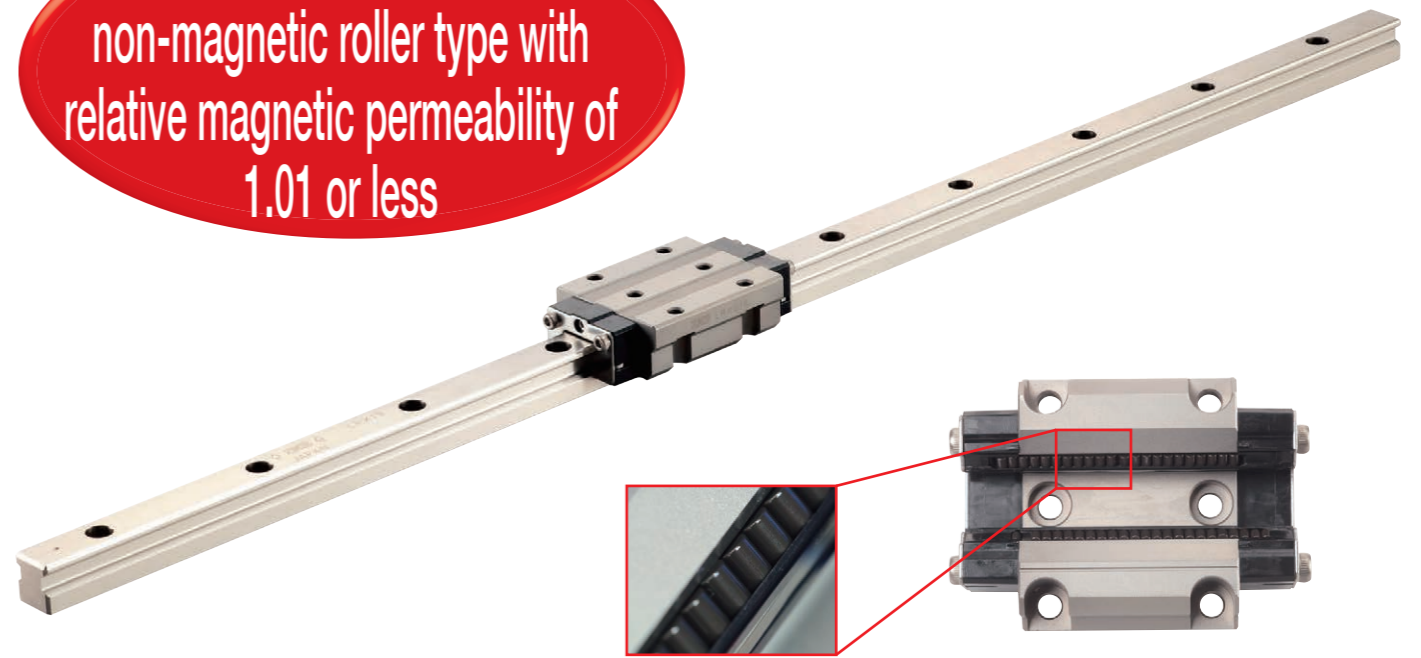

Features

World first for roller types

The first non-magnetic specifications ever realized in the world for endless motion roller type linear motion rolling guides

Relative magnetic permeability 1.01 or less

Allows for accurate and rapid positioning in environments affected by minimal magnetism

High corrosion resistance

Optimal for use in clean environment thanks to non-magnetic stainless steel

High running accuracy

The superb vibration characteristics of roller type linear motion rolling guides allow superior running accuracy

Non-magnetic stainless steel characteristics

Material name	Non-magnetic stainless steel	Silicon nitride ceramics
Characteristics		
Relative magnetic permeability (1)	1.01 or less (1.005)	1 (0.999991)
Electric conductivity	○	×
Hardness (HV)	380~450	1400~1600
Linear expansion coefficient (×10 ⁻⁶ /°C)	19.0 (20~400°C)	3.2 (20~400°C)
Specific gravity (g/cm)	7.9	3.2
Main ingredients	Fe, Mn, Cr	Si ₃ N ₄
Cost	○	△
Remarks	—	Good corrosion resistance

Note(1) () is only an example of the measurement value.

Selection of lubricant

By setting appropriate lubricants such as vacuum grease and low dust-generating grease, any operating environment can be supported.

● Applicable products

Series	Linear Roller Way Super X
Main model	LRX15, LRXD15, LRXS15

For detailed specifications or manufacturing information, please contact IKO.

■ Main component materials

Casing	Non-magnetic stainless steel
Track rail	Non-magnetic stainless steel
Cylindrical roller	Silicon nitride ceramics
End plate	Engineering plastic

Ball types can also be manufactured upon request. For detailed information, please contact IKO.

Stainless Linear Way and Linear Roller Way

A variety of stainless steel series

IKO Linear Way and Linear Roller Way lineup include products with stainless steel made parts instead of steel parts. As stainless steel is resistant to rust relative to high carbon steel made products, they are optimal for use in applications where oil and rust prevention oil are not preferred.

It is also suitable for use in cleanroom environment room, so use IKO clean grease that inhibits dust-generation amount together.

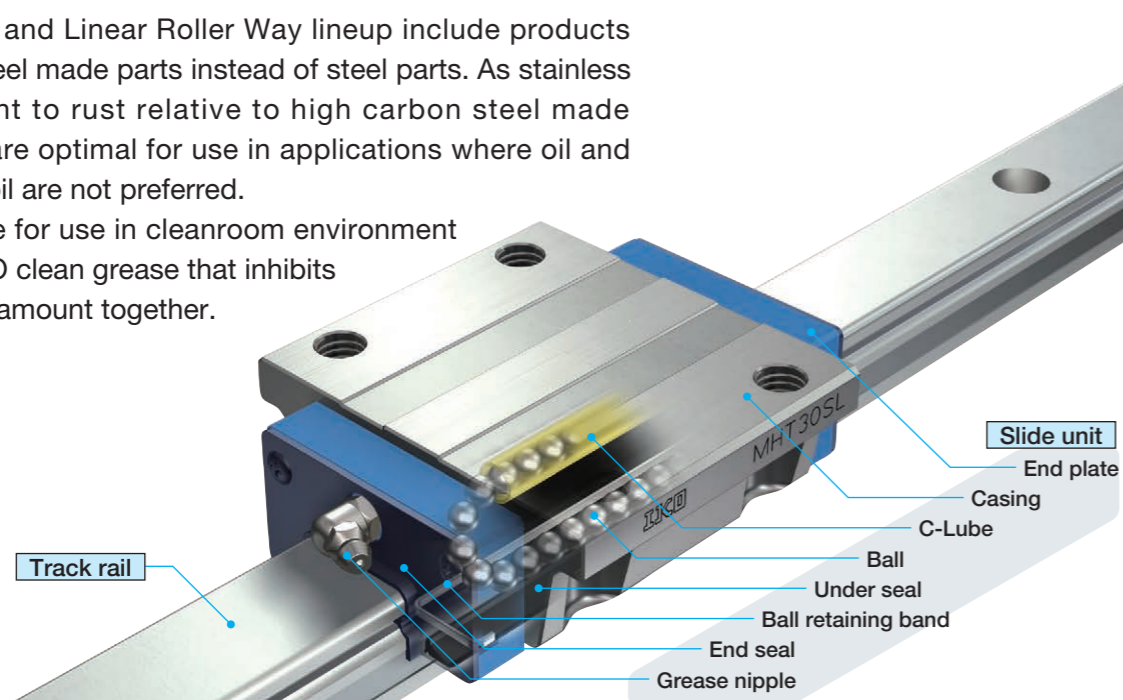

Main component materials	
Casing	Martensitic stainless steel
Track rail	Martensitic stainless steel
Ball	Martensitic stainless steel
Ball retaining band	Stainless steel
End plate	Engineering plastic
End seal	Stainless steel + Synthetic rubber
Grease nipple	Brass

Series name

Linear Way

Ball Type Miniature Series

- C-Lube Linear Way ML
- C-Lube Linear Way MLV
- Linear Way L
- Micro Linear Way L

Ball Type Compact Series

- C-Lube Linear Way ME
- Linear Way E

Ball Type High Rigidity Series

- C-Lube Linear Way MH
- Linear Way H

Ball Type Wide Type Series

- Linear Way F

Ball Type U-Shaped Track Rail Series

- C-Lube Linear Way MUL

Linear Roller Way

Roller Type

- C-Lube Linear Roller Way Super MX
- Linear Roller Way Super X

Combination with special specification corresponds to use in special environment!

Rust prevention

Black chrome surface treatment /L

Black chrome surface treatment on the track rail and slide unit improves rust prevention capacity.

Fluorine black chrome surface treatment /LF

Coating of fluorinated resin is applied over the black chrome surface treatment to prevent foreign substances from sticking and improve the rust prevention capacity.



Black chrome surface treatment

Features

- Thin film
- Uniform film
- Strong adhesion
- Excellent rust prevention capacity
- Low temperature processing to prevent distortion
- No peeling and no effects on life and cleanroom environment

Corrosion resistance comparison based on humidity cabinet test

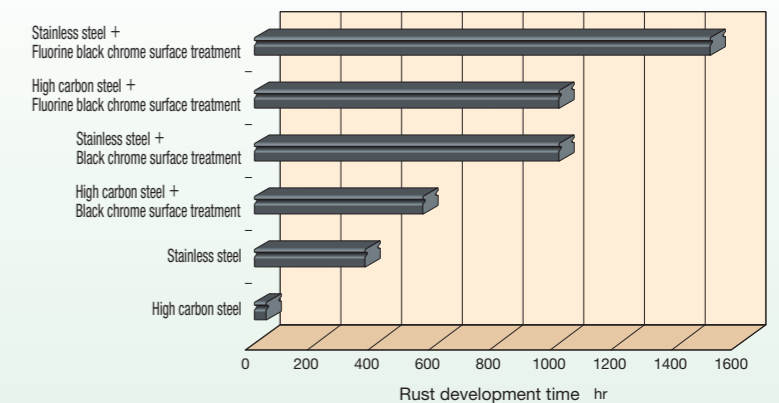

Test conditions Temperature 50°C, Relative humidity 95%RH

Special specification for special environment

IKO Linear Way and Linear Roller Way lineup include following special specifications to correspond to various special environments.

Dust protection

C-Wiper /RC

A lubricated C-Wiper can be installed on the outside of the end seal. It can be used for a long period of time because it enhances the dustproof effect and suppresses the increase in frictional resistance even in harsh environments where dust, chips, cutting fluid, etc. are present.

End seal, inner seal (/UR) and scraper (/Z) may be equipped as standard when you specify special specification /RC with C-Wiper.

If you need inner seal only, specify /UR.

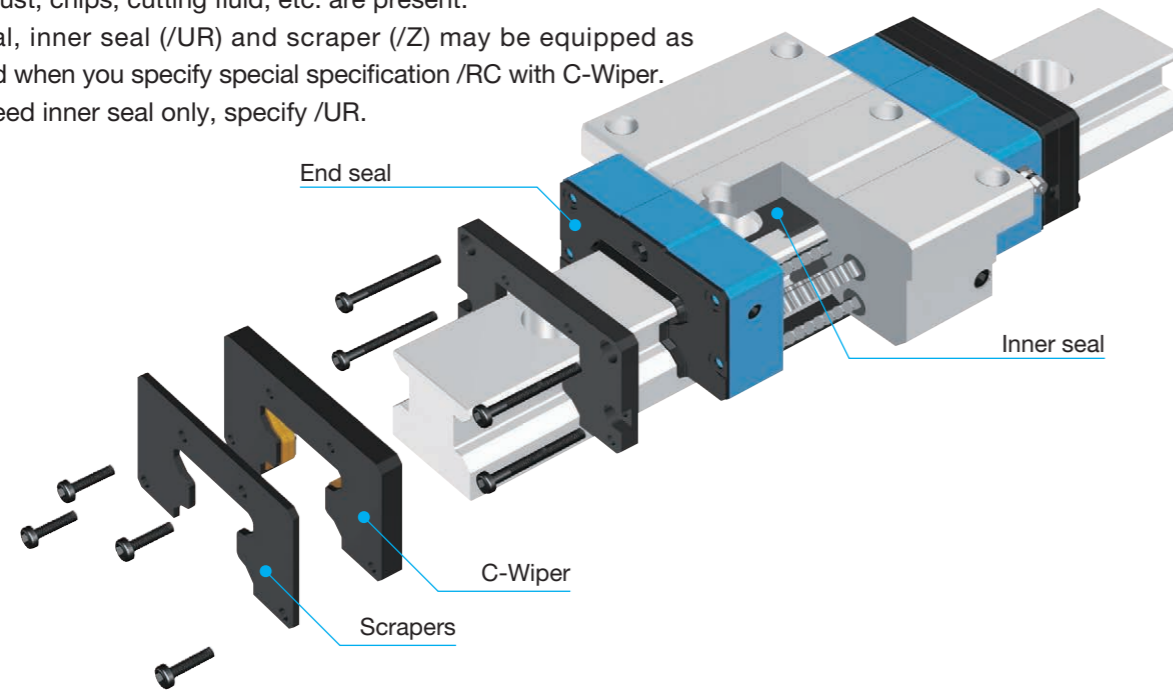

Applicable C-Wiper size

Model	Length of slide unit	Model code	Size								
			12	15	20	25	30	35	45	55	65
Flange type mounting from top / bottom	Short	MXC	—	—	○ ⁽¹⁾	○	○	○	○	○	○
	Standard	MX	—	—	○ ⁽¹⁾	○	○	○	○	○	○
	Long	MXG	—	—	○ ⁽¹⁾	○	○	○	○	○	○
	Extra long	MXL	—	—	○ ⁽¹⁾	○	○	○	○	○	○
Block type mounting from top	Short	MXDC	—	—	○	○	○	○	○	○	○
	Standard	MXD	—	—	○	○	○	○	○	○	○
	Long	MXDG	—	—	○	○	○	○	○	○	○
	Extra long	MXDL	—	—	○	○	○	○	○	○	○
Compact block type mounting from top	Short	MXSC	—	—	○	○	○	—	—	—	—
	Standard	MXS	—	—	○	○	○	○	○	—	—
	Long	MXSG	—	—	○	○	○	○	○	—	—
	Extra long	MXSL	—	—	○	○	○	—	—	—	—
Low profile flange type mounting from top	Standard	MXN	—	—	—	—	○	○	○	—	—
	Long	MXNG	—	—	—	—	○	○	○	—	—
	Extra long	MXNL	—	—	—	—	○	○	○	—	—
	Standard	MXNS	—	—	—	—	○	○	○	—	—
Low profile block type mounting from top	Long	MXNSG	—	—	—	—	○	○	○	—	—
	Extra long	MXNSL	—	—	—	—	○	○	○	—	—

Note (1) Also applicable to models mounting from bottom (MXHC20, MXH20, MXHG20, MXHL20).

Dust protection

Durability test result backing excellent dust protection effect of [C-Wiper]!

Durability test in environment with foreign substances

Test conditions

Test portion	MX35 T3 preload / caps for rail mounting holes and C-Wiper included
Maximum velocity	18 m/min
Stroke length	500 mm
Foreign substances	Fine metal chips Particle diameter lower than 125 μm Hardness 40 ~ 50HRC Application dose 1 g/hr (total dose: 1 kg)

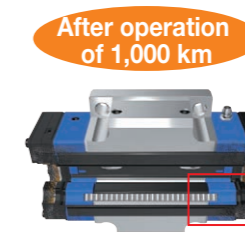
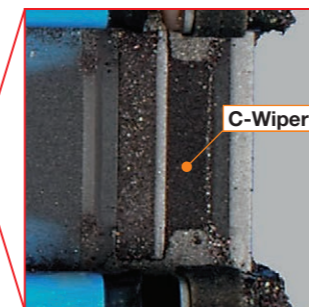
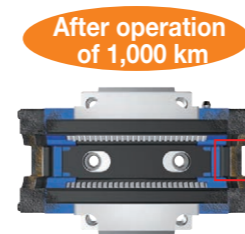
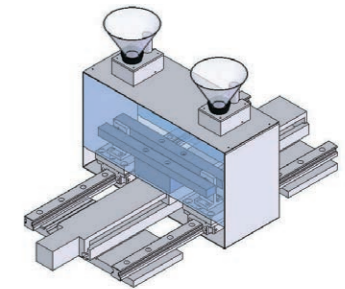

Only few foreign substances may get into the slide unit.

Only few foreign substances get into the way!

Durability test in coolant mist environment

Test conditions

Test portion	MX35 T3 preload / caps for rail mounting holes and C-Wiper included
Maximum velocity	115.2 m/min
Stroke length	300 mm
Coolant	Soluble type Dilute strength 20 times Spray amount 5 cc/hr

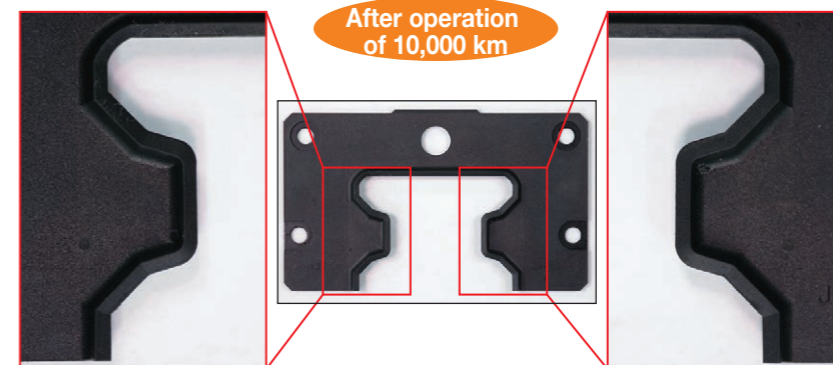
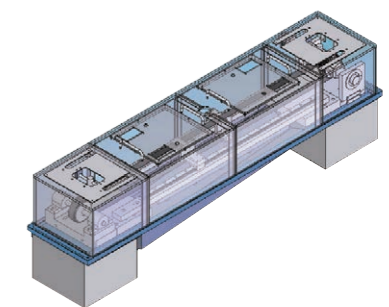

End seal is not damaged.

Wear condition of end seal lip tip

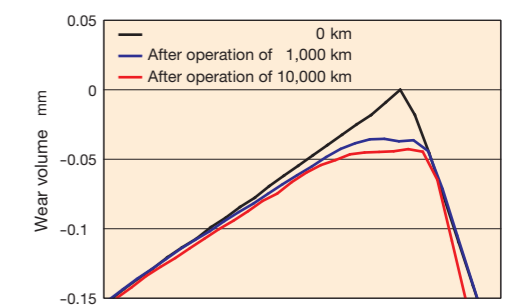

Wear on the end seal is negligible!

Special specification for special environment

Dust protection

Rail cover sheet

Rail cover sheet that consists of steel plate and adhesive tape and fastened to the dedicated track rail with groove on the track rail prevents foreign substances from entering into the slide unit.



Caps for rail mounting holes /F

Caps for rail mounting holes close the track rail mounting holes to prevent foreign substances from entering into the slide unit.
Contact IKO for aluminum alloy caps for rail mounting holes.

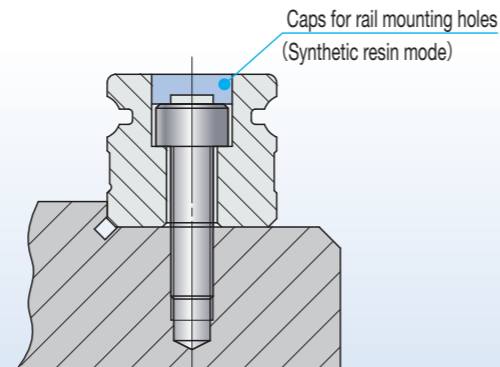

Dust protection

Double end seals /V

Double end seals improve the dust protection property further.

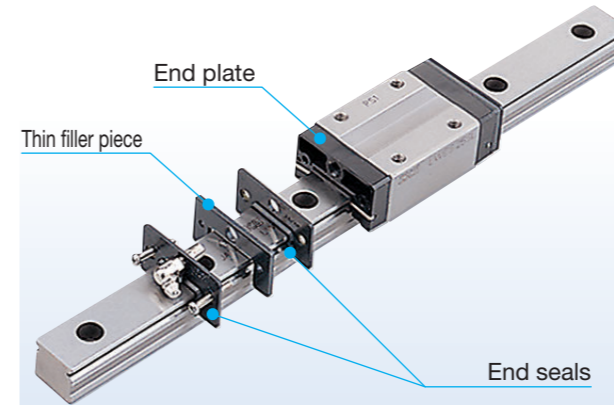

Scraper /Z

Mounted to the outside of end seal, it may remove large foreign substances adhering to the track rail.

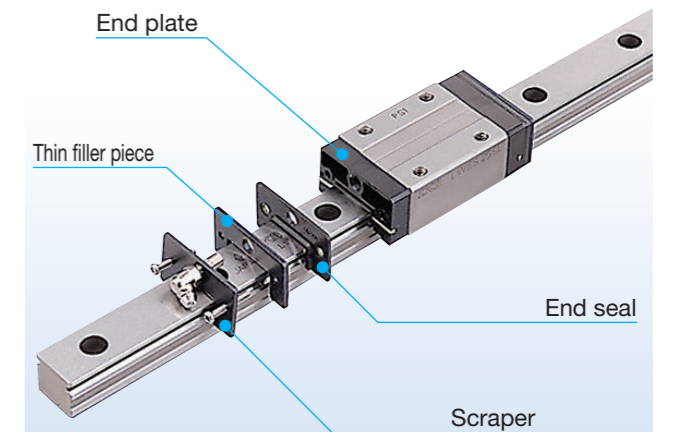

Rail cover plate /PS

Rail cover plate totally covers the upper surface of the track rail to prevent foreign substances from entering into the track rail.



Track rail mounting from bottom

This is the specification that track rail is fixed from the mounting surface side. As there are no mounting holes on the track rail upper surface, adherence with the seal is superior and better dust protection effect is achieved.

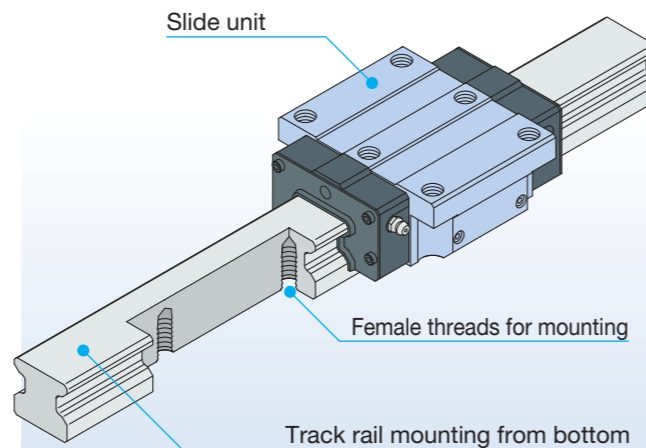

Female threads for bellows /J

Female threads for bellows are prepared on the slide unit and track rail ends.

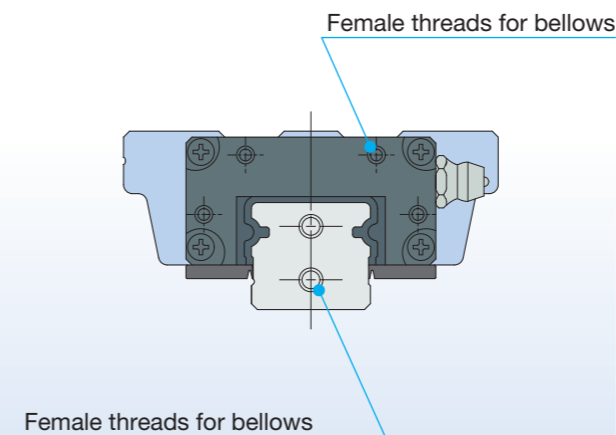

Specific bellows

Dust protection cover over the exposed part of the track rail.

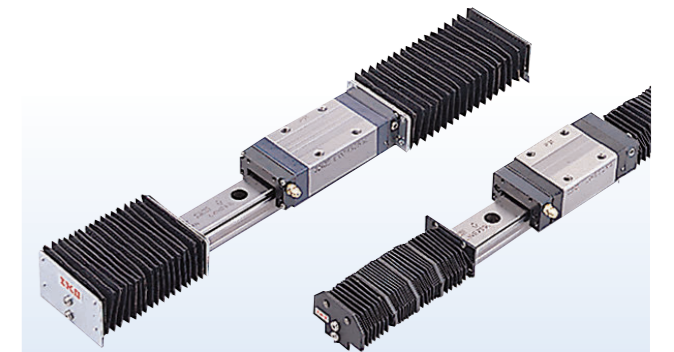

Special specification for special environment

Lubrication

With C-Lube plate /Q

Lubrication parts to substantially reduce the need for lubrication management, i.e. grease job.

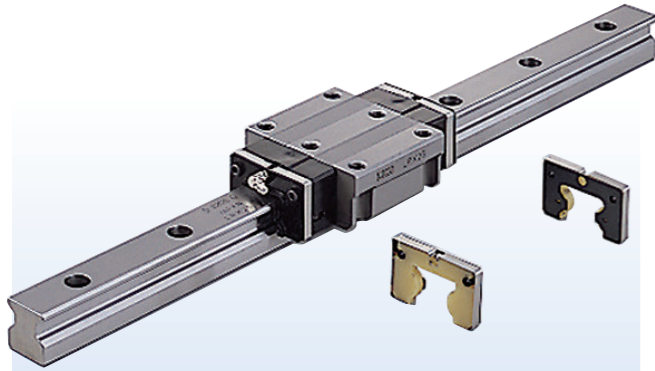

Low Dust-Generation Grease for Clean Environment CGL /YCL

For this grease, mixed soap is used as thickener and synthetic oil and low pour point mineral oil are mixed with base oil, so it has excellent low dust generating performance, rolling resistance, lubrication, and rust prevention property.

Bellows cartridge (80 g)
JG80 /CGL

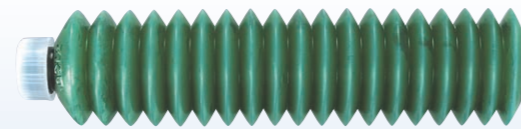

With miniature greaser (2.5 ml)
MG2.5B /CGL



Low Dust-Generation Grease for Clean Environment CG2 /YCG

For this grease, urea is used as thickener and synthetic oil is used as base oil, so it has excellent low dust generating performance, operating temperature range, lubrication property, rust prevention property and oxidation stability.

Bellows cartridge (80 g)
JG80 /CG2

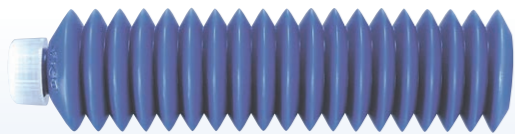

With miniature greaser (2.5 ml)
MG2.5B /CG2



MG10 /CG2 with 10 ml are also available.

Anti-Fretting Corrosion Grease AF2 /YAF

Grease with excellent fretting-proof corrosion property.

Bellows cartridge (80 g)
JG80 /AF2

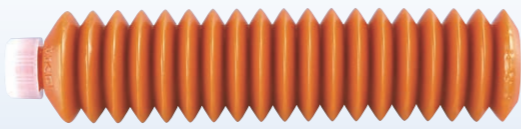

With miniature greaser (2.5 ml)
MG2.5B /AF2



Other special grease

For special grease for vacuum or high temperature, please contact IKO.

Others

Stainless steel end plate /BS

End plate is changed to stainless steel.

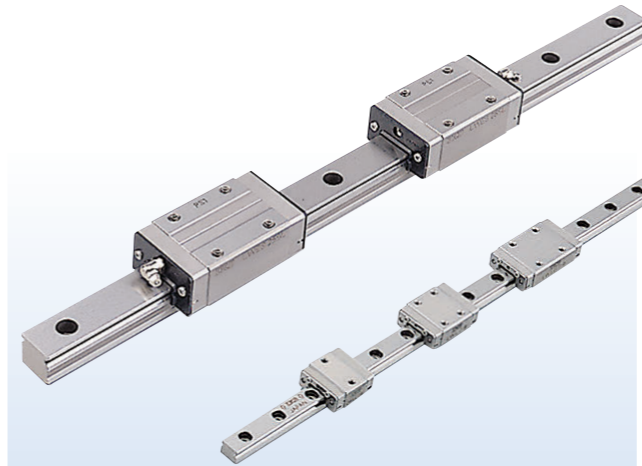

Special environment seal /RE

The end and under seals are replaced with end seals for special environment that can be used at high temperatures. When it is used in high temperature environment, stainless steel end plate (/BS) and high temperature grease should be combined.

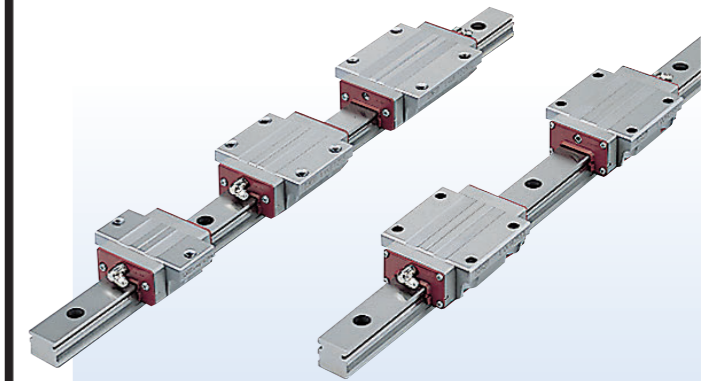

The photo shows a combination of special environment seal (/RE) and stainless steel end plate (/BS).

IKO can offer products for special environment!

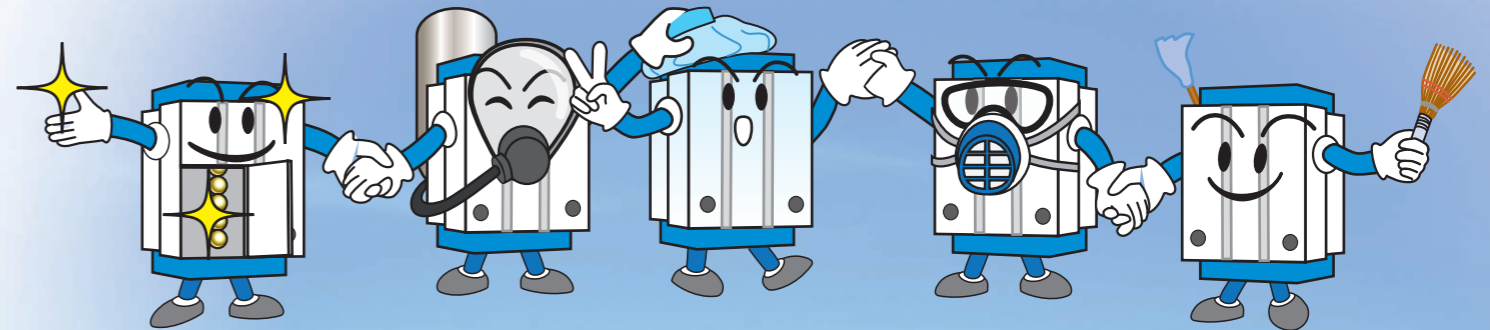

If needed, please contact IKO.