

NOT TO SCALE

**SPECIFICATIONS**

- CONCRETE** - 6000 PSI minimum in 28 days.
- REINFORCEMENT** - 2X4 12 gauge ASTM A185 65 KSI plain finish cont. around perimeter of vault, #3 bars (Grade 60) rebar, per engineering spec. as required for vaults design.
- LID REINFORCEMENT** - #3 rebar 6" center, both ways plus a mat on 2X4 12 gauge wire.

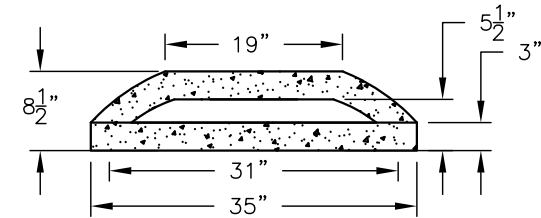

**SECTION "B"  
EPOXY LINED LID**

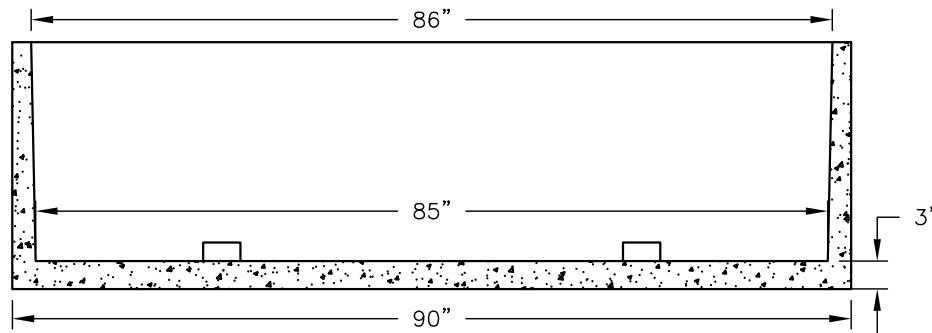

**FRONT VIEW  
SECTION "A"**

**EPOXY LINED BODY**

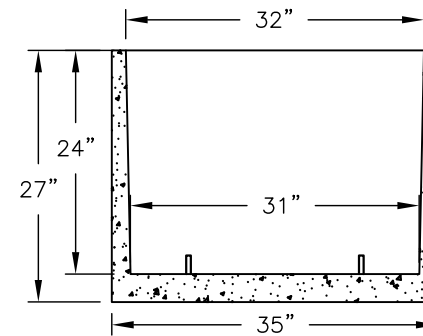

**"A"  
RIGHT SIDE VIEW**

WWW.TEXASPRECAST.NET

TOLL FREE: 800-633-3235  
PHONE: 409-925-2502

**TEXAS PRECAST, L.L.C.**

18303 HIGHWAY 6  
SANTA FE, TEXAS 77510

**MODEL  
CONCRETE EPOXY LINED VAULT**