

SPECIFICATIONS

CONCRETE: 6000 PSI minimum in 28 days.

REINFORCEMENT: 6X6 10 gauge ASTM A185 65 KSI plain finish cont. around perimeter of tank, #3 bars (Grade 60) rebar, per engineering spec. as required for tanks design.

LID REINFORCEMENT: #3 rebar 6" center, both ways plus a mat on 6X6 10 gauge wire.

PIPE PENETRATIONS: Inlet and outlet seals water tight that meet ASTM C923.

PARTITION WALLS: If present, is poured monolithically.

INSTALLATION: By contractor per code with minimum of 12" on all sides of unit is required. Depth of base and material shall meet the specifications and requirements for the type of soil at the setting location. The leveling of the material will prevent tank from cracking after filling with water.

BACK FILL: Backfilling must be done before filling with water! This must be done on all sides by lowering sand. DO NOT PUSH FROM SIDES.

RING AND LID: Material - Cast Iron, ASTM A48, Class 30B/35B (35B Traffic Duty)

Load Rating Regular Duty - 12,000 lbs.

Load Rating Traffic Duty - 40,000 lbs.

ENGINEERING DATA: To adhere to UPC/IPC and recommended regional plumbing standards, the grease interceptor is structurally and hydraulically engineered.

TANK WARRANTY: Limited to replacement for 1 year. Full warranty provided with tank purchase at location and at www.texasprecast.net

APPROXIMATE CAPACITY: 1296 Gallons

APPROXIMATE WEIGHT: 12820 lbs.

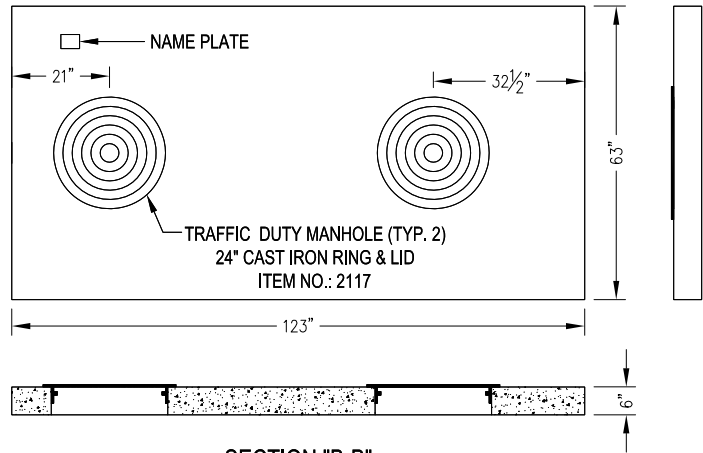

SECTION "B-B"

SAND-OIL SEPARATOR LID

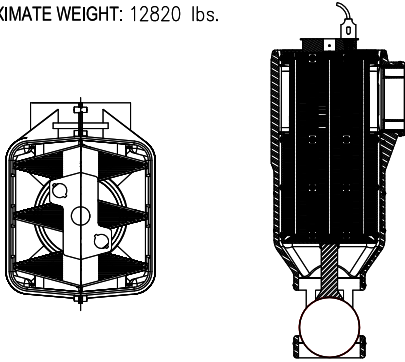

DETAIL "A"

POLYLOK EFFLUENT FILTER (PL-625)

CERTIFIED TO ANSI/NSF STD. 46 1/32" FILTRATION 10,000 GPD

(SEE WEBSITE FOR MORE DETAILS)

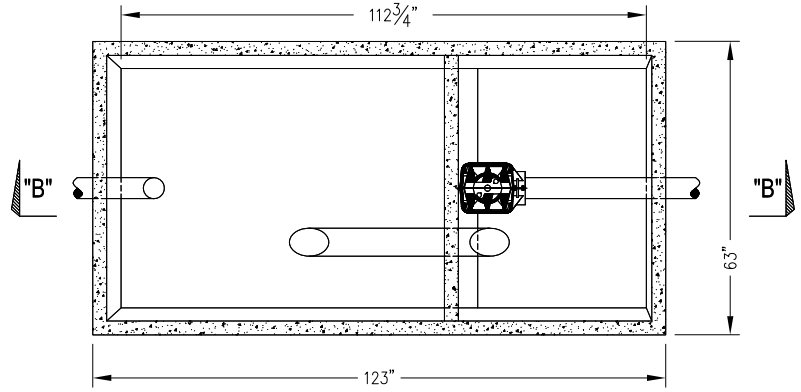

TOP VIEW

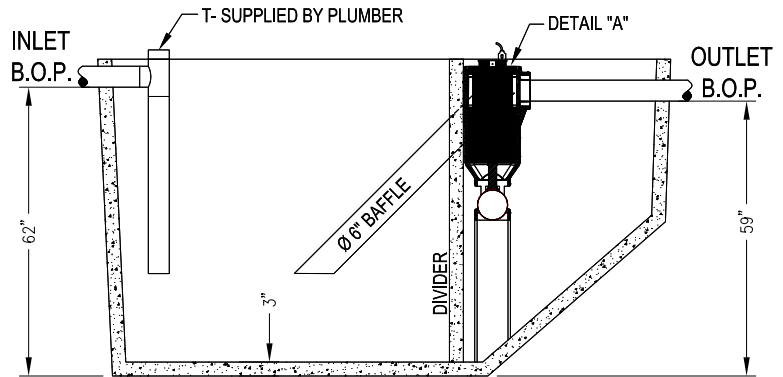
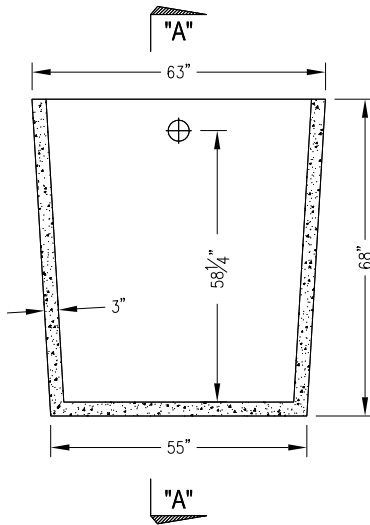

SECTION "A-A"

SAND-OIL SEPARATOR BODY

WWW.TEXASPRECAST.NET

TOLL FREE: 800-633-3235
PHONE: 409-925-2502

TEXAS PRECAST, L.L.C.

18303 HIGHWAY 6
SANTA FE, TEXAS 77510

MODEL
1000 SAND-OIL SEPARATOR