



US00927151B2

(12) **United States Patent**  
**McBay**

(10) **Patent No.:** **US 9,927,151 B2**  
(45) **Date of Patent:** **\*Mar. 27, 2018**

(54) **GEOHERMAL ENERGY COLLECTION SYSTEM**

(71) Applicant: **David Alan McBay**, Palo Alto, CA (US)

(72) Inventor: **David Alan McBay**, Palo Alto, CA (US)

(73) Assignee: **David Alan McBay**, Palo Alto, CA (US)

(\* ) Notice: Subject to any disclaimer, the term of this patent is extended or adjusted under 35 U.S.C. 154(b) by 160 days.  
  
This patent is subject to a terminal disclaimer.

(21) Appl. No.: **14/877,568**

(22) Filed: **Oct. 7, 2015**

(65) **Prior Publication Data**  
US 2016/0187031 A1 Jun. 30, 2016

**Related U.S. Application Data**  
(63) Continuation of application No. 13/815,266, filed on Feb. 14, 2013, now Pat. No. 9,181,931.  
(Continued)

(51) **Int. Cl.**  
**F24J 3/08** (2006.01)  
**F28D 20/00** (2006.01)  
(Continued)

(52) **U.S. Cl.**  
CPC ..... **F24J 3/081** (2013.01); **F03G 7/04** (2013.01); **F24J 3/08** (2013.01); **F28D 15/00** (2013.01);  
(Continued)

(58) **Field of Classification Search**  
CPC ..... F24J 3/081; F24J 3/08; F28D 20/0034; F28D 15/00; F28D 2020/0047;  
(Continued)

(56) **References Cited**

U.S. PATENT DOCUMENTS

4,209,991 A \* 7/1980 Anderson ..... B63H 25/46  
114/144 B  
4,350,014 A \* 9/1982 Sanchez ..... B63B 35/44  
114/264

(Continued)

OTHER PUBLICATIONS

Anoop Mathur "Heat Transfer and Latent Heat Storage in Inorganic Molten Salts for Concentrating Solar Power Plants" Solar Energy Technologies Program Review, (May 26, 2010).

(Continued)

*Primary Examiner* — Hoang Nguyen

(74) *Attorney, Agent, or Firm* — IP Clinic at Lincoln Law School of San Jose

(57) **ABSTRACT**

This invention provides a method of extracting geothermal energy, generally comprising the steps of: insertion of a thermal mass into a Heat Absorption Zone, absorbing heat in thermal mass, raising the thermal mass to a Heat Transfer Zone, and transferring the heat from the thermal mass. The acquired heat can be used to generate electricity or to drive an industrial process.

The thermal mass can have internal chambers containing a liquid such as molten salt, and can also have structures facilitating heat exchange using a thermal exchange fluid, such as a gas or a glycol-based fluid.

In some embodiments, two thermal masses are used as counterweights, reducing the energy consumed in bringing the heat in the thermal masses to the surface. In other embodiments, solid or molten salt can be directly supplied to a well shaft to acquire geothermal heat and returned to the surface in a closed loop system.

**31 Claims, 20 Drawing Sheets**

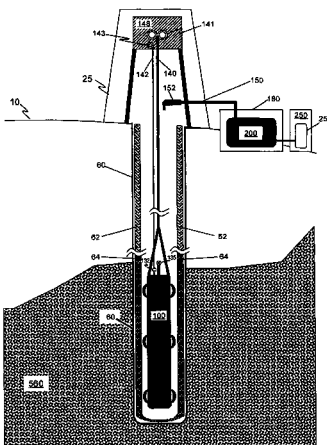

**Related U.S. Application Data**

- (60) Provisional application No. 61/633,756, filed on Feb. 17, 2012.
- (51) **Int. Cl.**  
*F03G 7/04* (2006.01)  
*F28D 15/00* (2006.01)
- (52) **U.S. Cl.**  
 CPC .. *F28D 20/0034* (2013.01); *F28D 2020/0047* (2013.01); *Y02E 10/10* (2013.01); *Y02E 10/12* (2013.01); *Y02E 10/46* (2013.01); *Y02E 60/142* (2013.01); *Y02E 70/30* (2013.01); *Y02P 80/24* (2015.11)
- (58) **Field of Classification Search**  
 CPC . F03G 7/04; Y02P 80/24; Y02E 10/10; Y02E 10/12; Y02E 10/46; Y02E 60/142; Y02E 70/30  
 USPC ..... 60/641.2-641.4  
 See application file for complete search history.

**References Cited**

U.S. PATENT DOCUMENTS

4,355,513	A *	10/1982	Girden .....	F03G 7/05 417/108
7,320,221	B2	1/2008	Bronicki	
7,621,129	B2	11/2009	DuBois	
7,900,450	B2	3/2011	Gurin	
7,984,613	B2	7/2011	DuBois	
8,109,094	B2	2/2012	Petty	
8,117,843	B2 *	2/2012	Howard .....	F24J 3/06 60/641.6
8,235,140	B2	8/2012	Wideman et al.	
8,272,437	B2	9/2012	Bour et al.	
8,316,955	B2	11/2012	Saar et al.	
8,327,932	B2	12/2012	Karanikas et al.	
8,464,535	B2	6/2013	White et al.	
8,534,069	B2	9/2013	Parrella	
8,616,000	B2	12/2013	Parrella	
8,640,772	B2	2/2014	Bour et al.	
8,677,752	B2	3/2014	DuBois	
9,181,931	B2 *	11/2015	McBay .....	F03G 7/04
9,181,932	B2 *	11/2015	Edwards .....	F03G 7/05
2009/0272129	A1	11/2009	Petty	
2009/0272545	A1	11/2009	Bour	
2009/0320475	A1	12/2009	Parrella	
2010/0000736	A1	1/2010	Bour et al.	
2010/0032156	A1	2/2010	Petty et al.	
2010/0154417	A1	6/2010	Ferguson et al.	
2010/0269501	A1	10/2010	Parrella	
2010/0270001	A1	10/2010	Parrella	
2010/0270002	A1	10/2010	Parrella	
2010/0276115	A1	11/2010	Parrella	
2010/0306125	A1	12/2010	Petty et al.	
2011/0029293	A1	2/2011	Petty et al.	
2011/0083436	A1	4/2011	White et al.	
2011/0203575	A1	8/2011	Emery	
2012/0098277	A1	4/2012	Petty	
2012/0181034	A1	7/2012	Bour et al.	
2013/0056198	A1	3/2013	Bour et al.	
2013/0075089	A1	3/2013	Bour et al.	
2013/0099491	A1	4/2013	Iovenitti et al.	
2013/0139807	A1	6/2013	Mandelberg et al.	
2014/0000838	A1	1/2014	Parrella	
2014/0047836	A1	2/2014	Parrella	

**OTHER PUBLICATIONS**

Cetiner, Mustafa; Holcomb, David; Cetiner, Sacit: "An Overview of Liquid Fluoride Salt Heat Transport Systems" Oak Ridge National Laboratory (Sep. 2010).

Cheryl Fellows: "World Renewable Energy Forum" vol. 2, (May 2012).

Daniel J. Whittenberger: "Estimated Heats of Fusion of Fluoride Salt Mixtures" NASA Technical Memorandum (Jun. 1986).

Domenico Giardini: "Geothermal Quake Risks Must be Faced," Nature, vol. 462, p. 848-849 (Dec. 2009).

Dow Chemical Co. "Dowtherm SR-1 Heat Transfer Fluid: Engineering Specifications for Closed-Loop HVAC Systems" (Apr. 2002).

Duffield, et al.: "Geothermal Energy— Clean Power from the Earth's Heat" United States Geological Survey, (2003).

Duratherm: "DuraClean FG Material Safety Data Sheet" (Jan. 2011).

Dynalene: "Dynalene HT (High Temperature Heat Transfer) Fluid Specification Sheet" (2011).

Emilio Sola: "Molten Salt a New Generation?" (Sep. 21, 2012).

Foong, et al.: "Numerical Study of a High Temperature Latent Heat Storage (200-300 C) Using Eutectic Nitrate Salt of Sodium Nitrate and Potassium Nitrate." Proceedings of the COSMOL Conference (2010).

Gregory Kolb: "An Evaluation of Possible Next-Generation High-Temperature Molten-Salt Power Towers" Sandia National Laboratories (Dec. 2011).

GTherm: "Gtherm Single Well Engineered Geothermal System (SWEGS) Compared to Enhanced Geothermal System(EGS)" Gtherm. <http://www.gtherm.net/geothermal-power-generation/gtherm-swags-compared-to-egs/> (Last accessed Dec. 3, 2014).

Guomundur O. Fridleifsson: "Iceland Deep Drilling Project (IDDP)—10 Years Later—Still an Opportunity for International Collaboration." Proceedings World Geothermal Congress (Apr. 2010).

International Geothermal Association: "Geothermal—A Natural Choice" (Apr. 2010).

John P. Cise "Specific Heat and Latent Heat of Fusion." New York Times (Jan. 3, 2012).

John W. Lund, "100 Years of Geothermal Power." Geo-Heat Center Bulletin, p. 11-19 (Sep. 2004).

Julie Way: "Storing the Sun: Molten Salt Provides Highly Efficient Thermal Storage." World Renewable Energy Forum (Jun. 2008).

Matthew J. Wald: "Storehouses for Solar Energy Can Step in When the Sun Goes Down." New York Times (Jan. 2, 2012).

Novelli, et al. "A quick look at pneumatic conveying system basics." Powder, Bulk and Engineering (Mar. 1, 2010).

Rees, et al: "A Study of Geothermal Heat Pump and Standing Column Well Performance." American Society of Heating, Refrigerating, and Air-Conditioning Engineers Transactions, vol. 110, part 1, p. 3-13 (2004).

Sharma, et al.: "Review on Thermal Energy Storage with Phase Change Materials and Applications." Renewable & Sustainable Energy Reviews 13 (2009) 318-345.

Solar PACES Conference Schedule. SolarPACES 2011 (2011).

Susan Petty: "Protecting the Environment—and Our Future" (2007).

Tester, et al.: "The future of Geothermal Energy." Idaho National Laboratory Report (2006).

Zhe Wang: "Modeling Study of Single-Well Enhanced Geothermal Systems (EGS)" Masters of Science Thesis, Stanford University (Jun. 2009).

\* cited by examiner

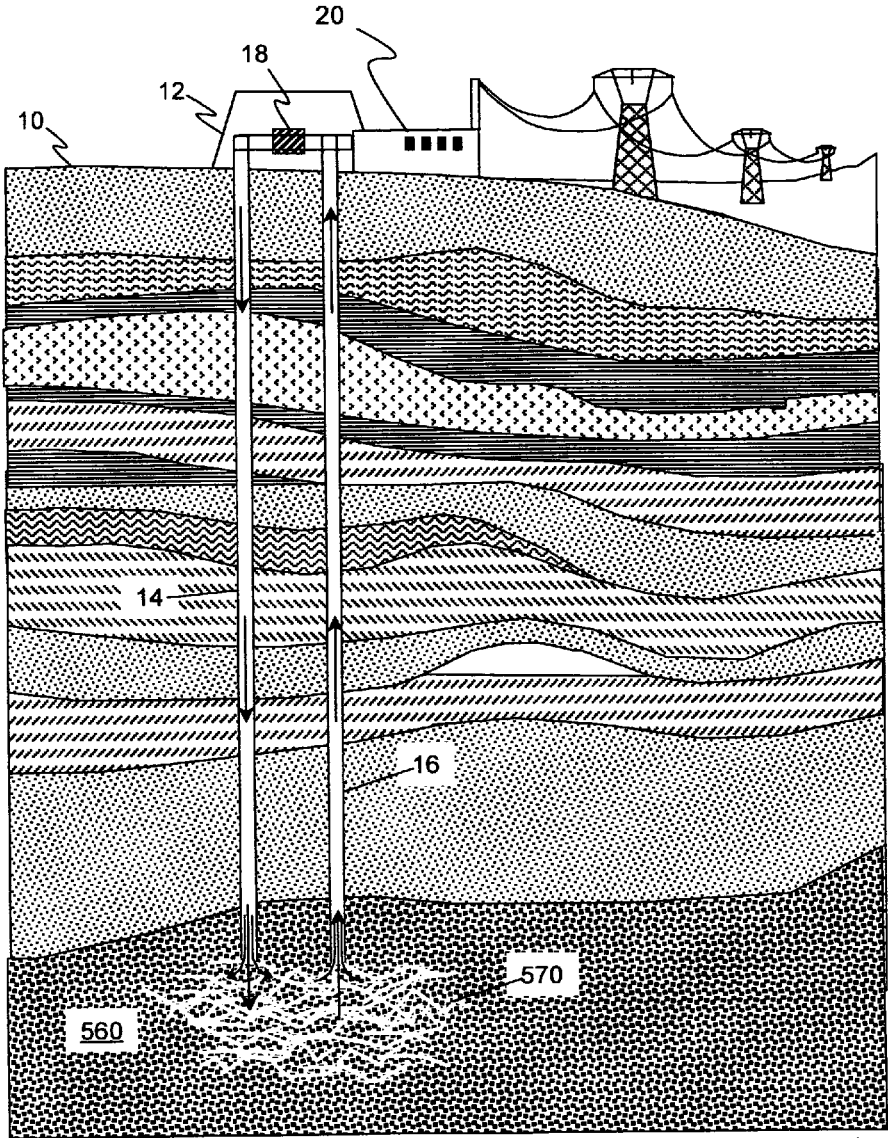

Prior Art

FIG. 1

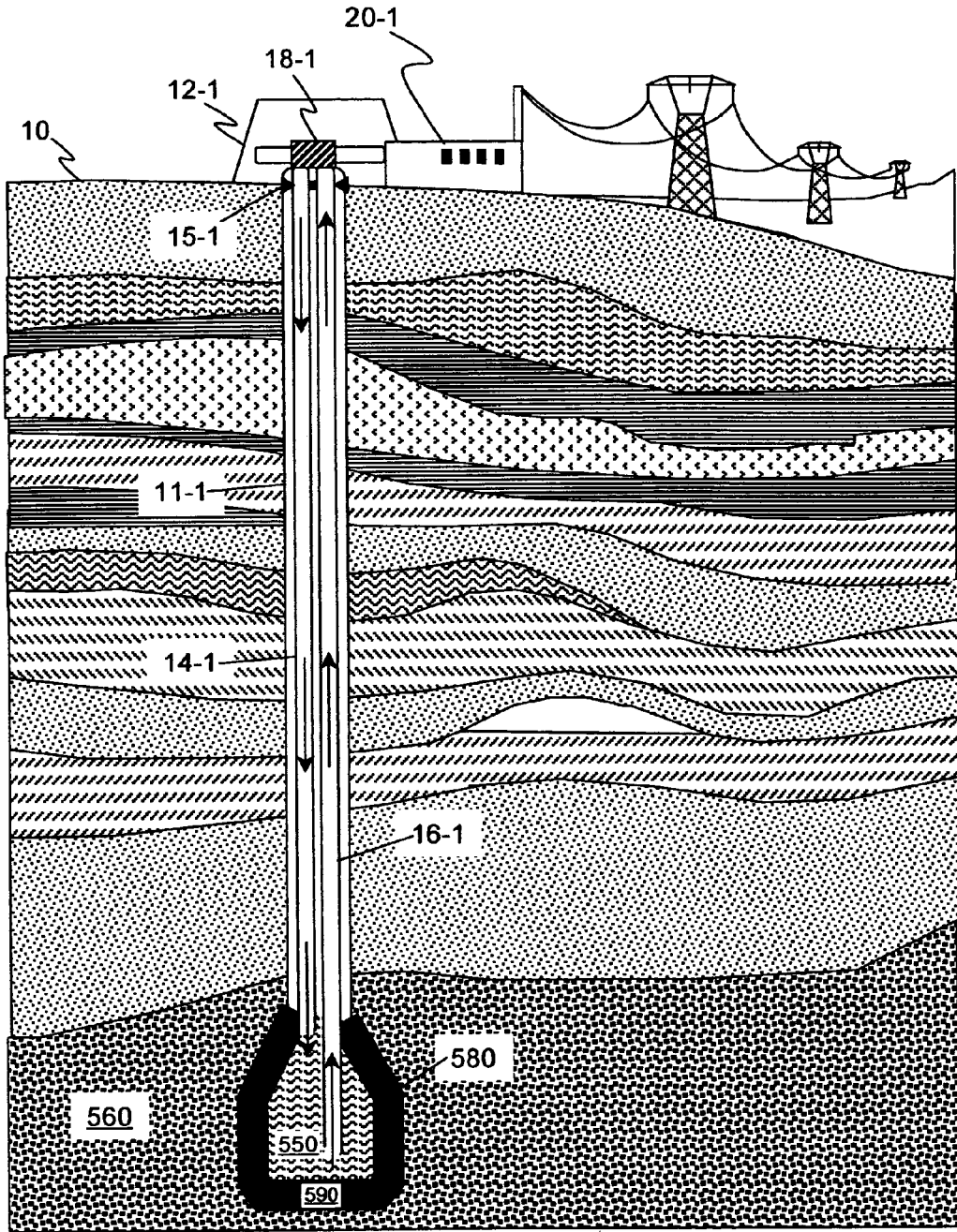

Prior Art

FIG. 2

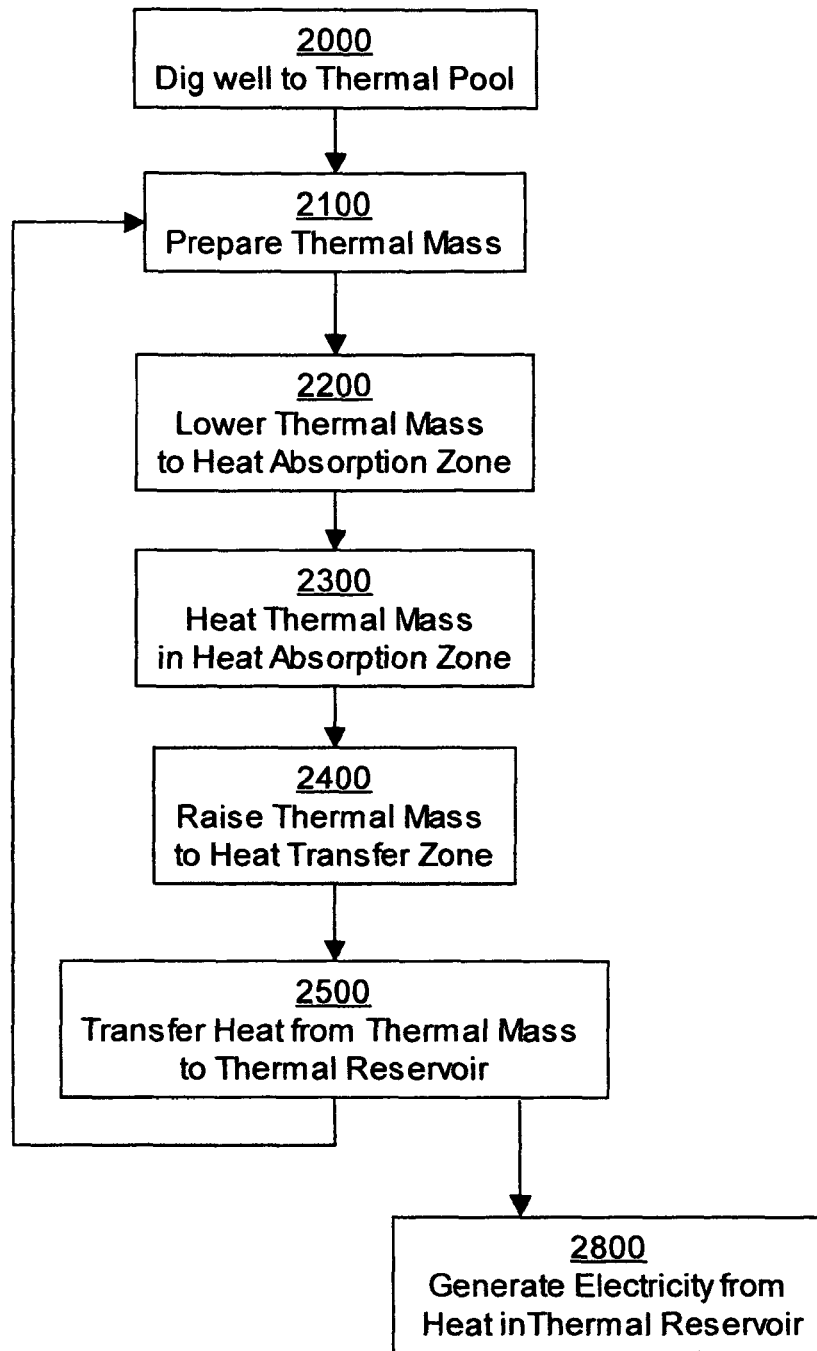

FIG. 3

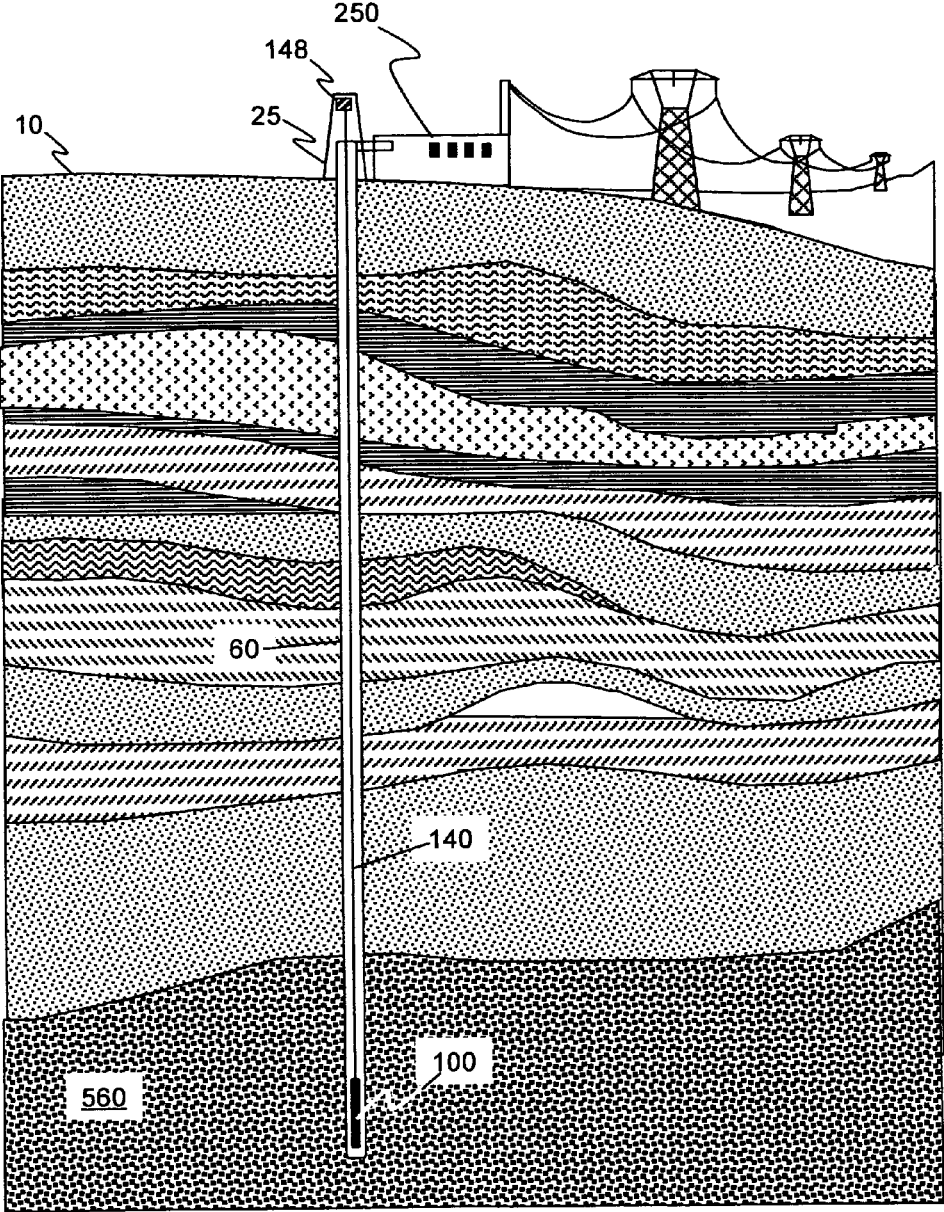

FIG. 4

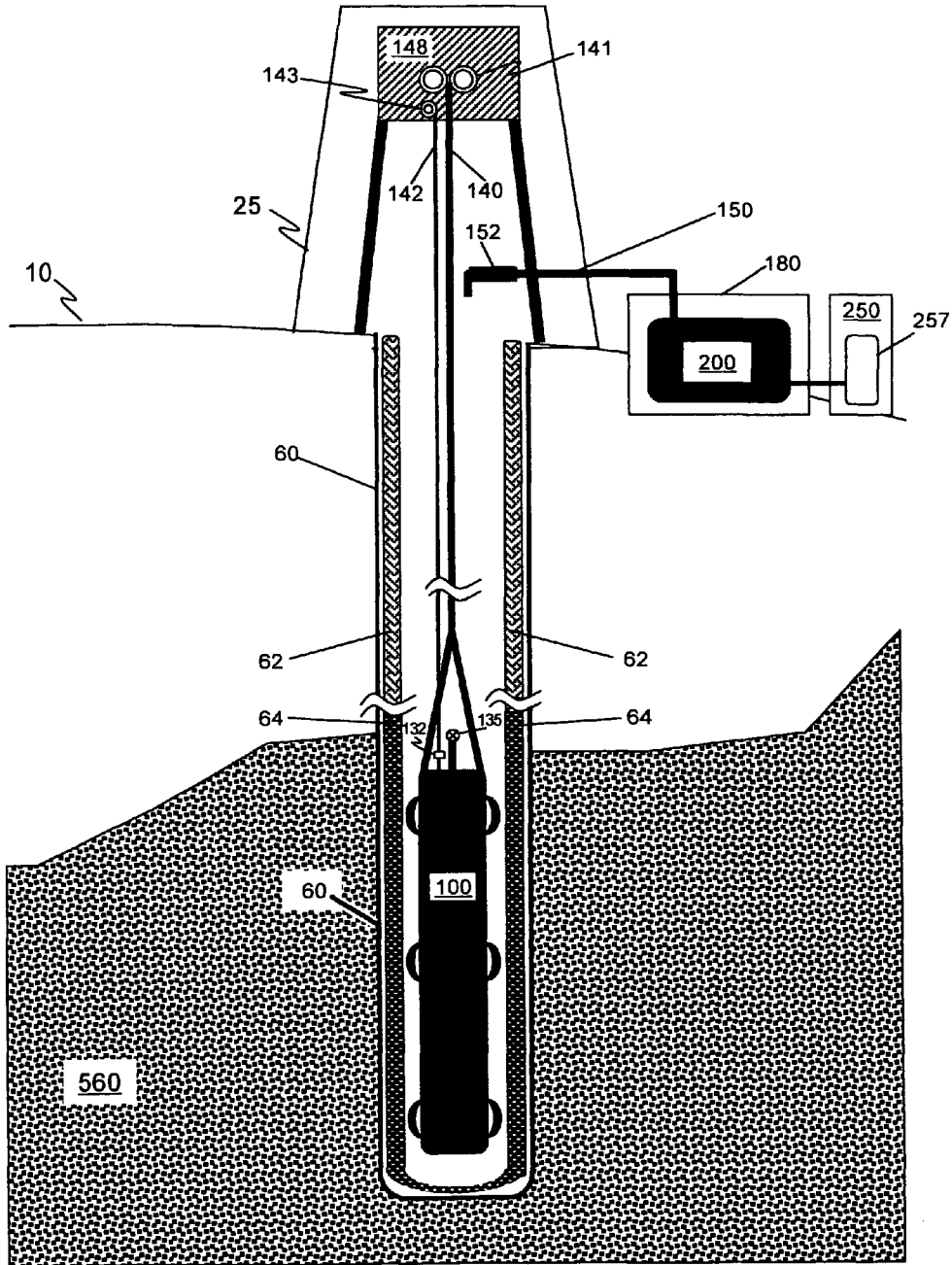

FIG. 5

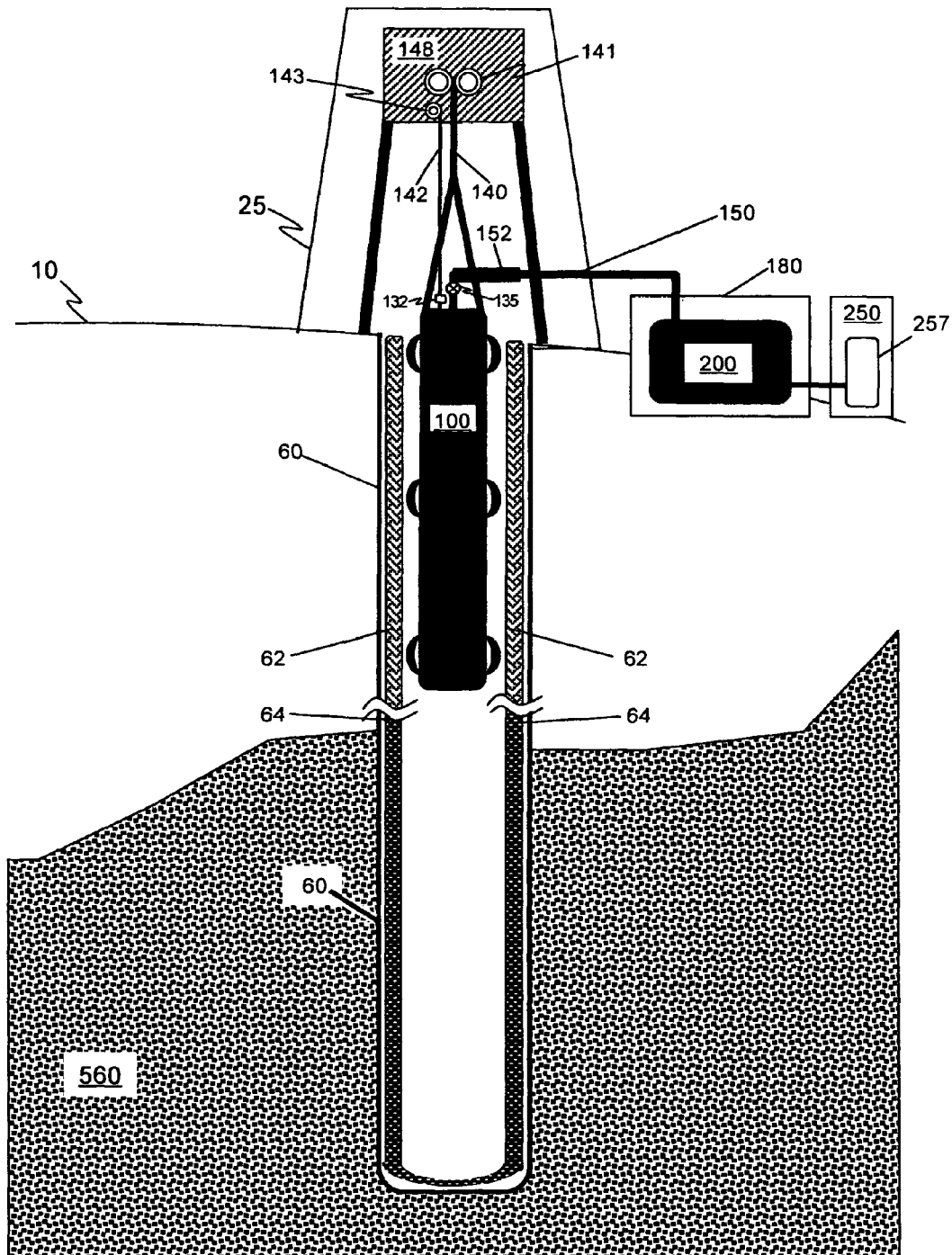

FIG. 6



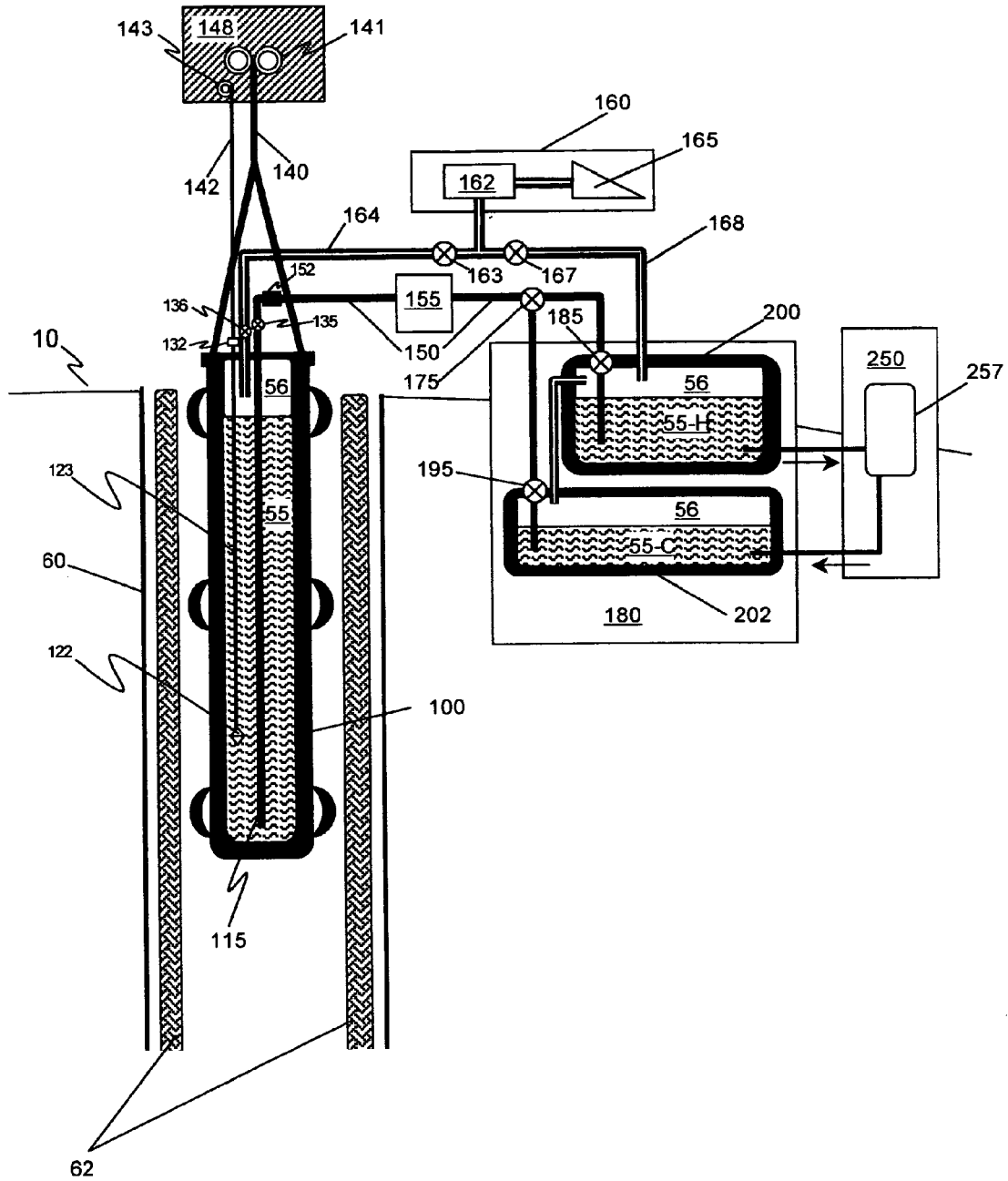

FIG. 7

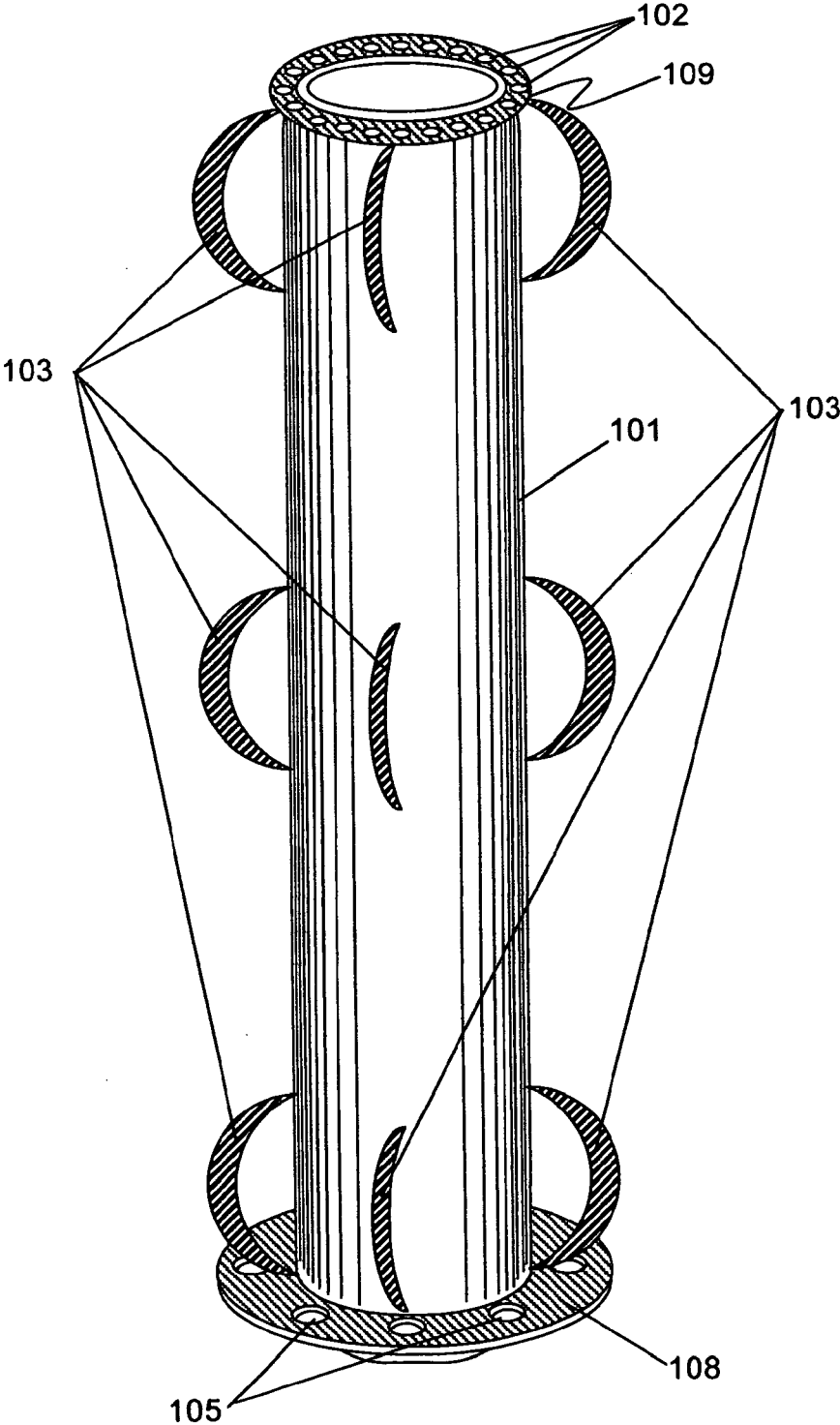

FIG. 8

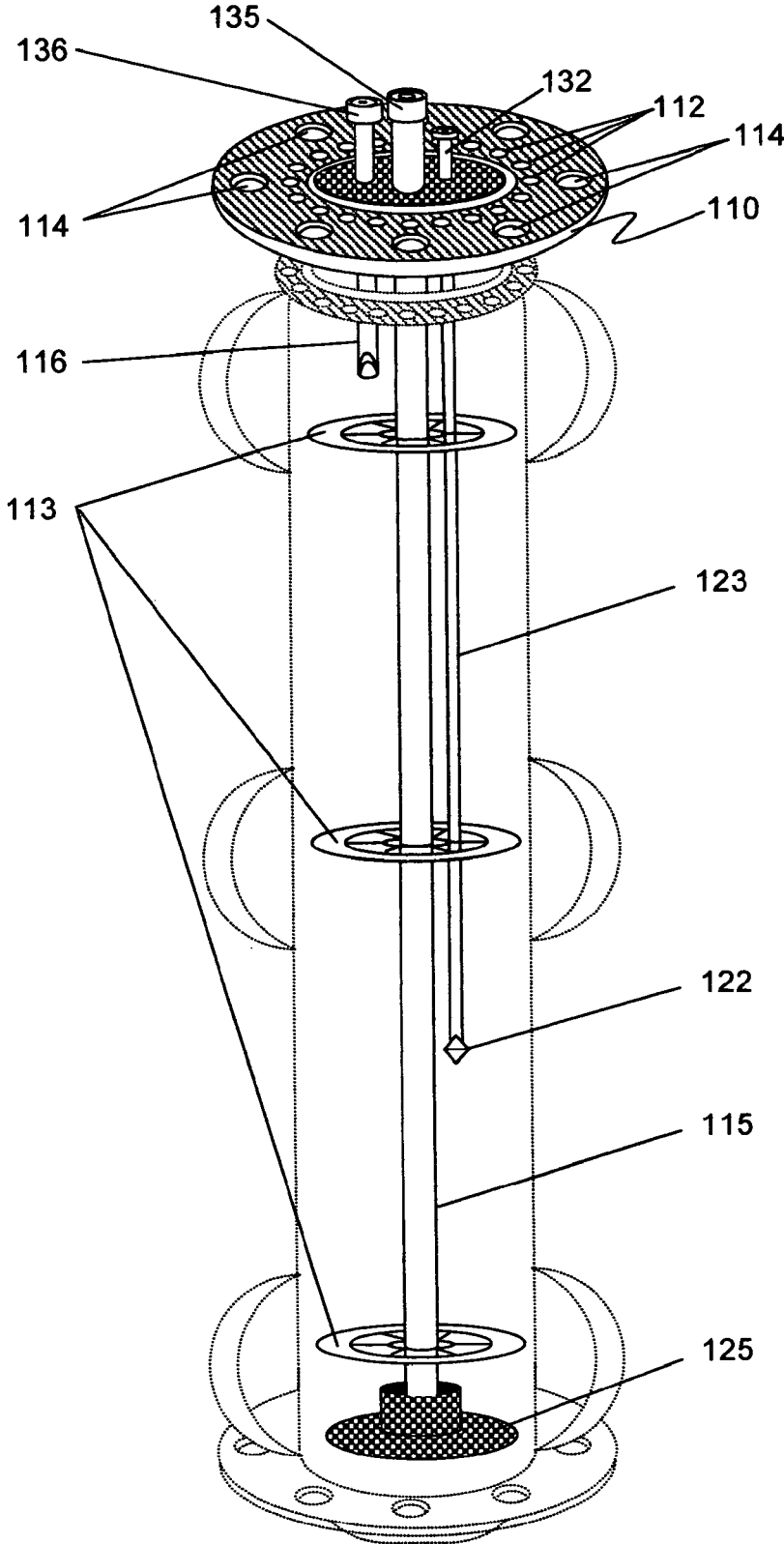

FIG. 9

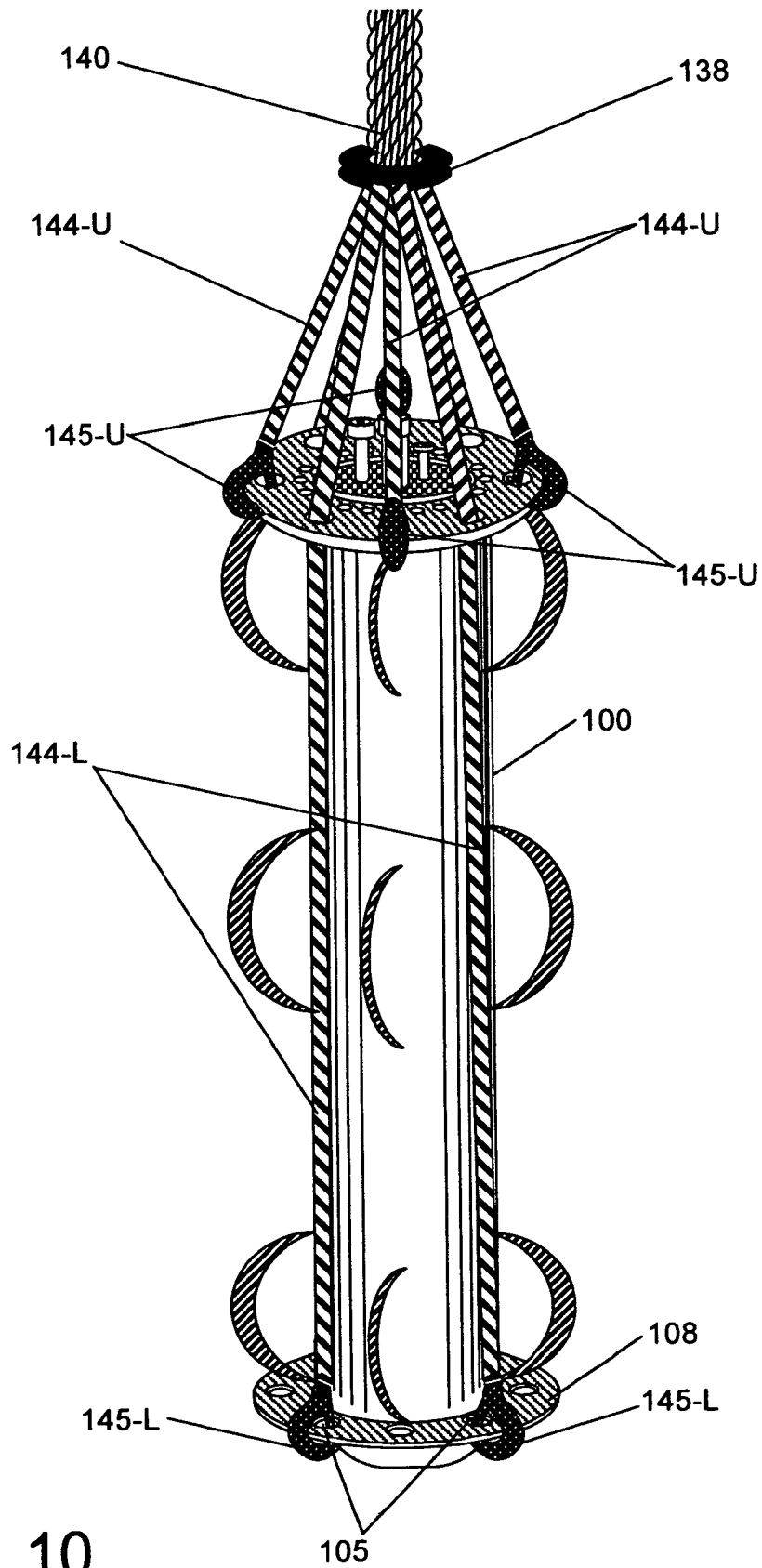

FIG. 10

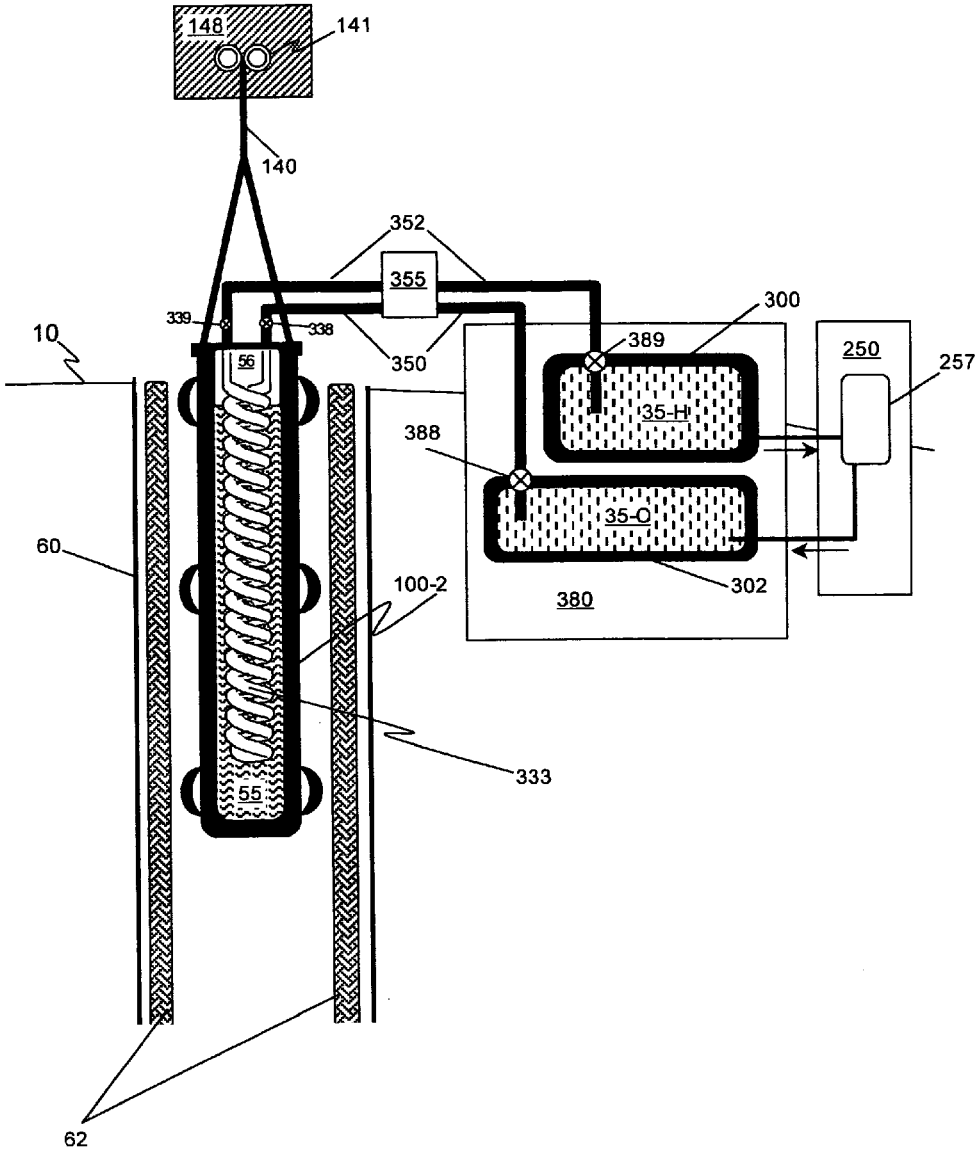

FIG. 11

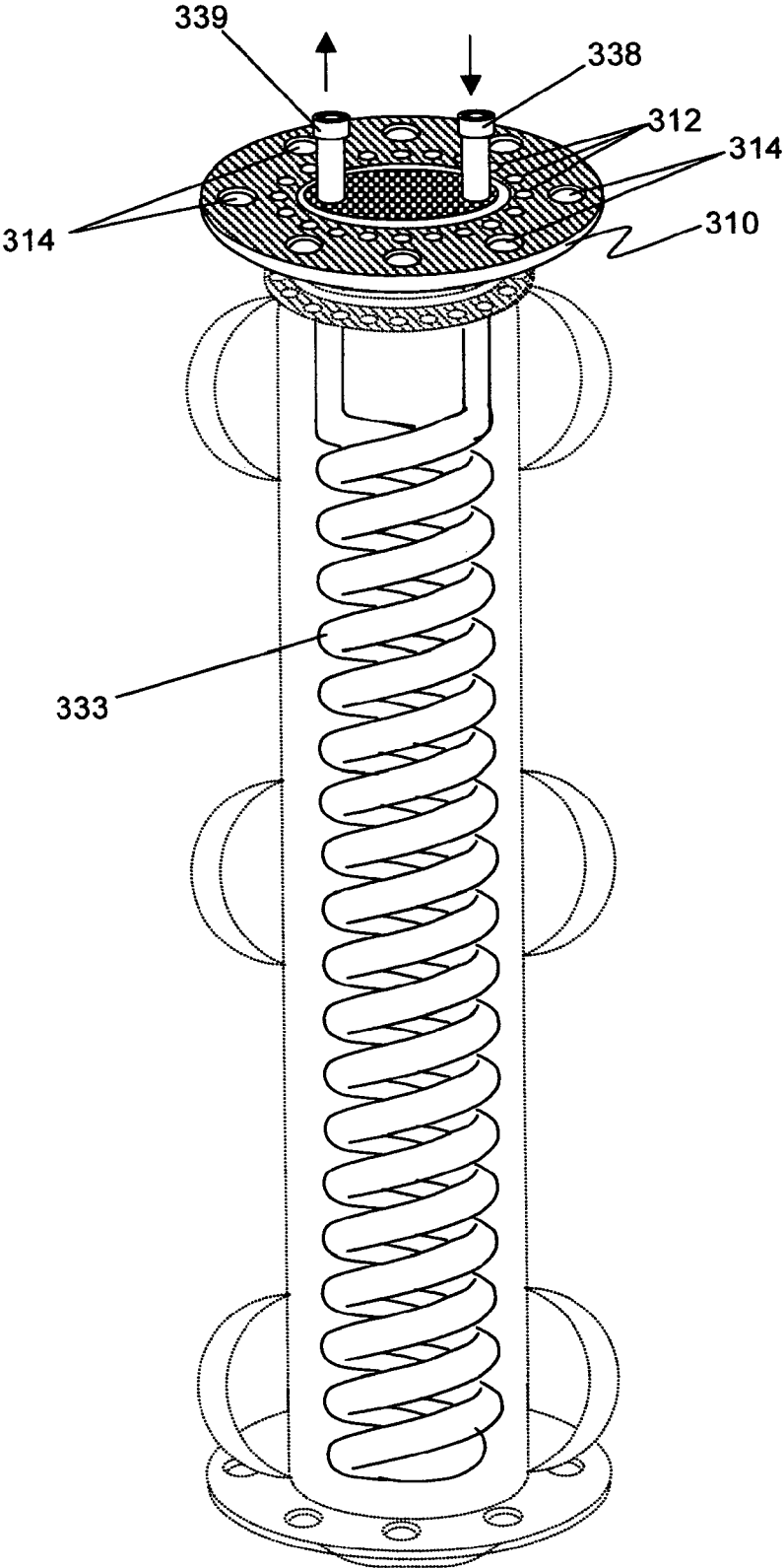

FIG. 12

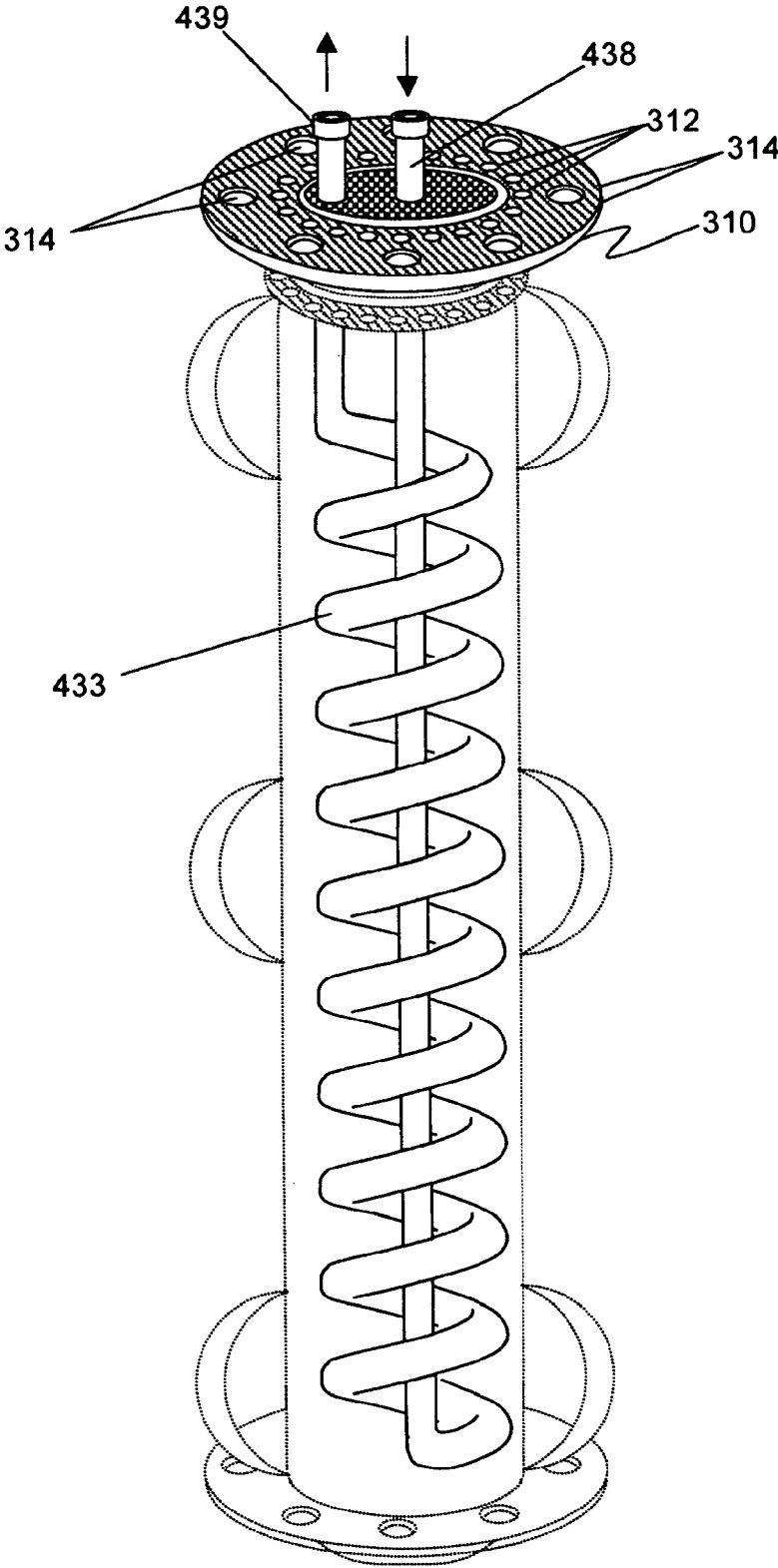

FIG. 13

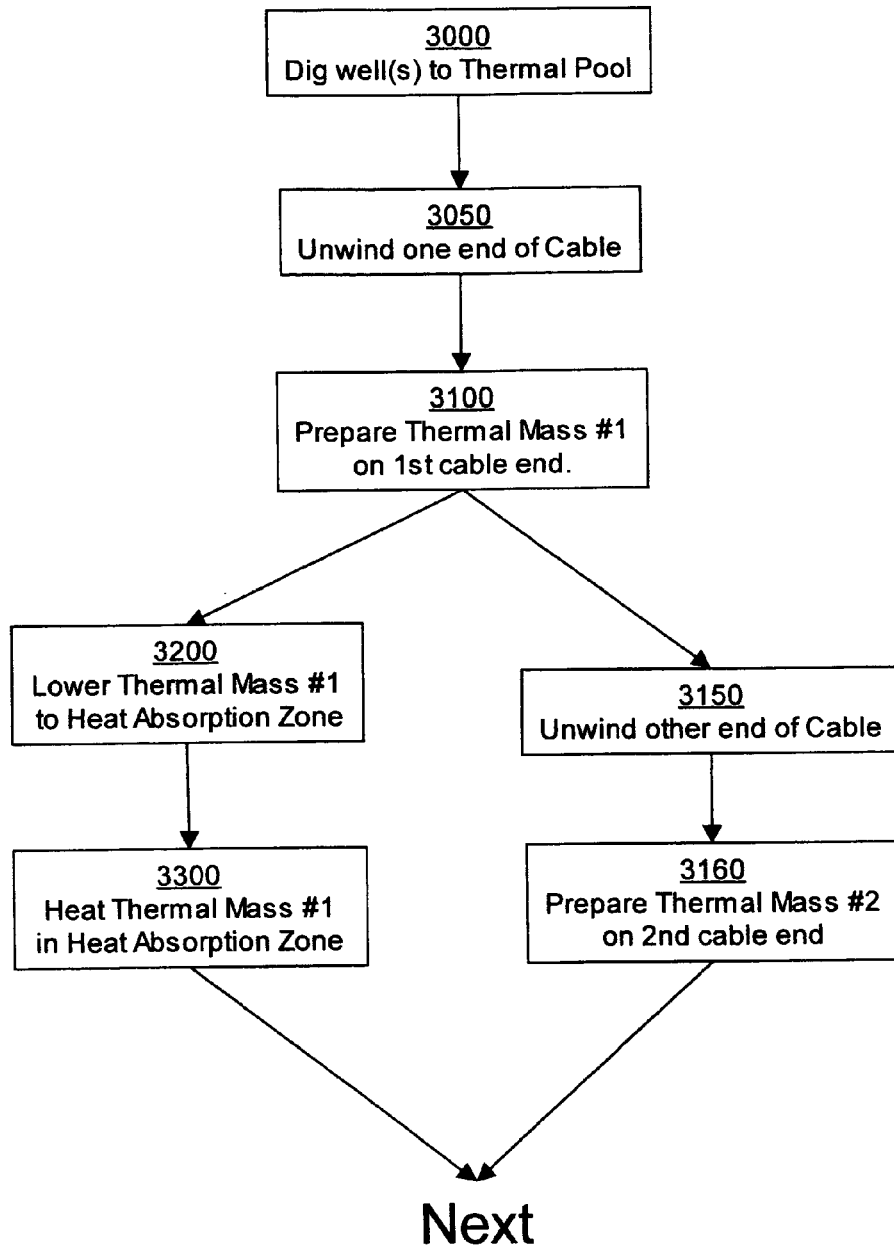
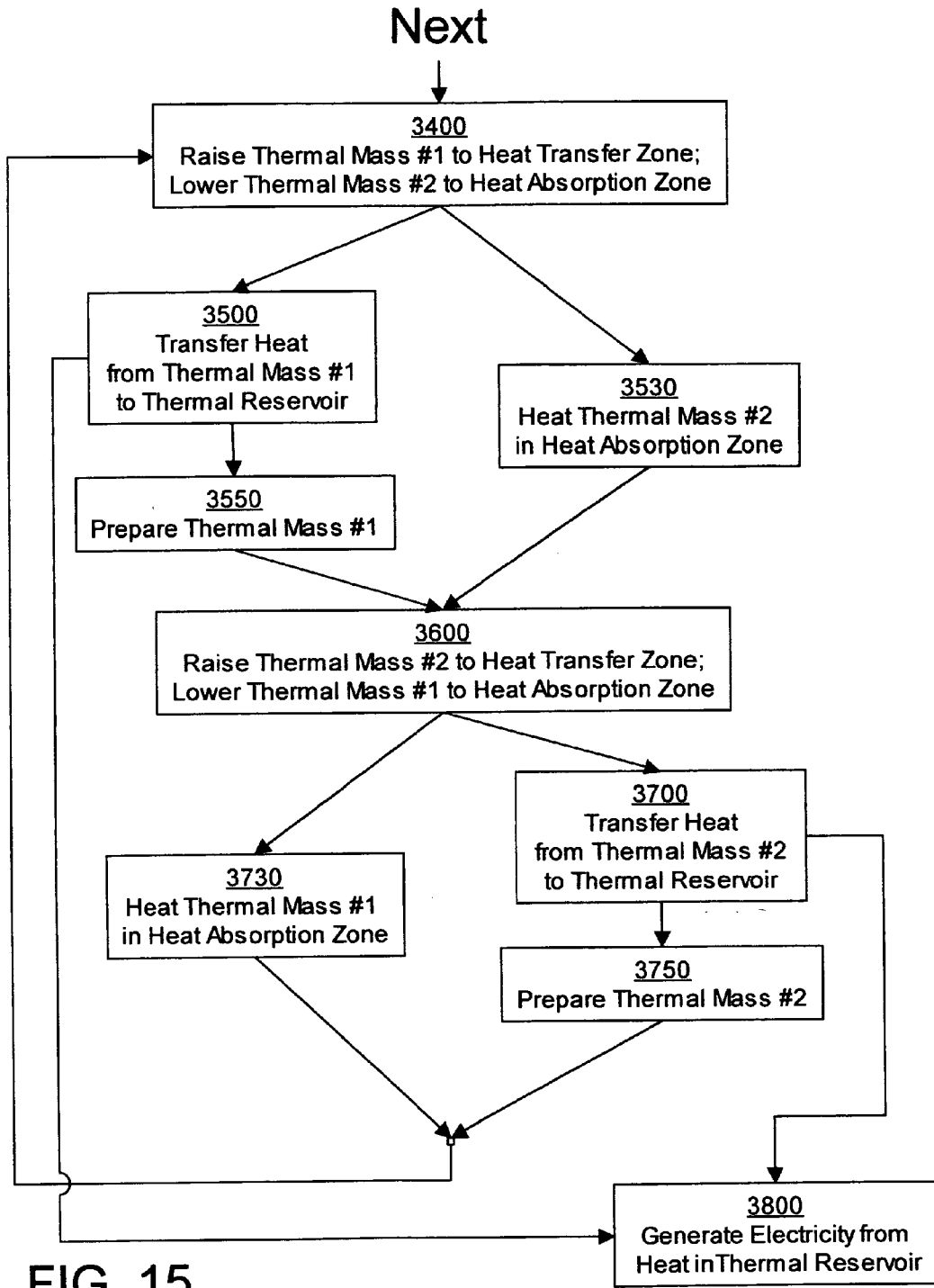

FIG. 14





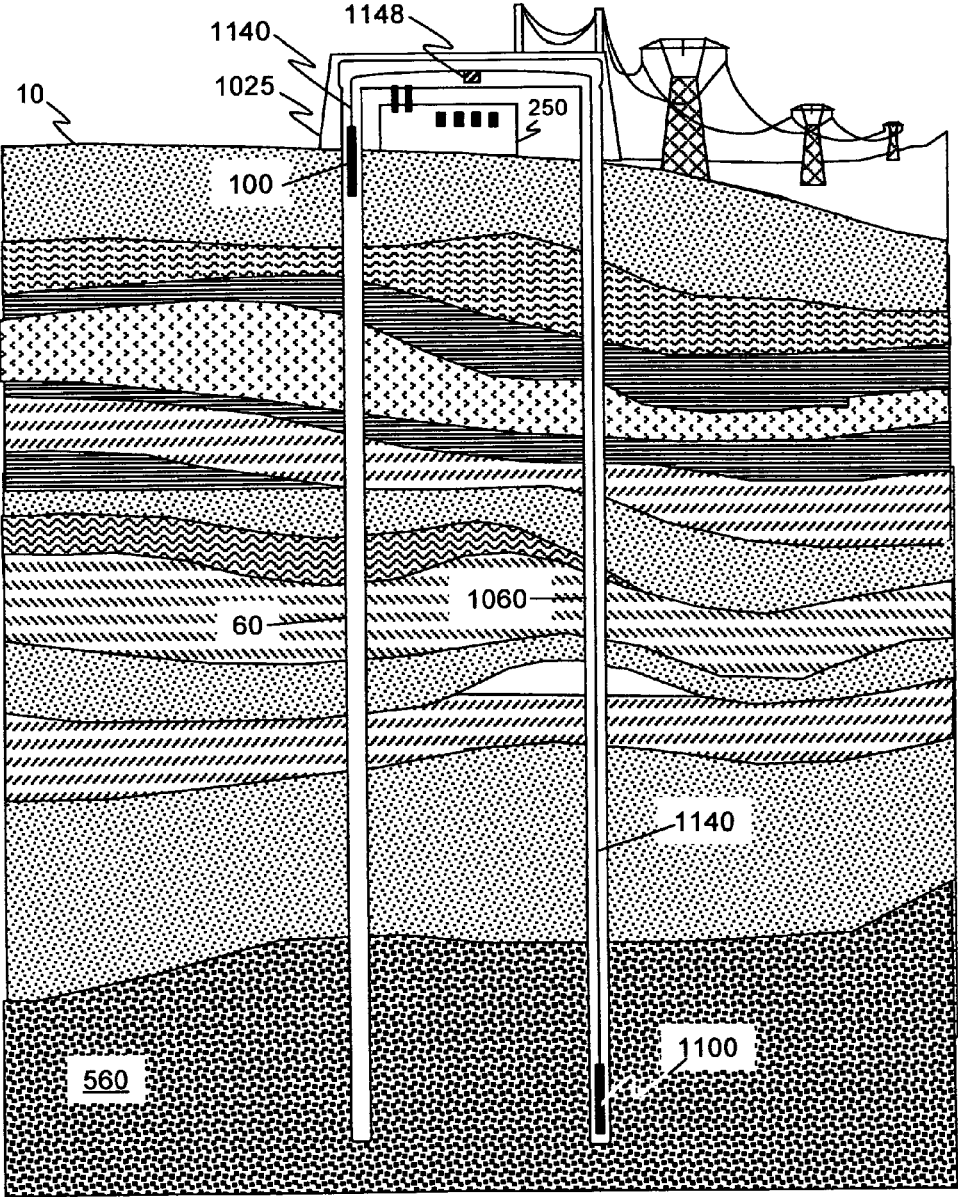

FIG. 16

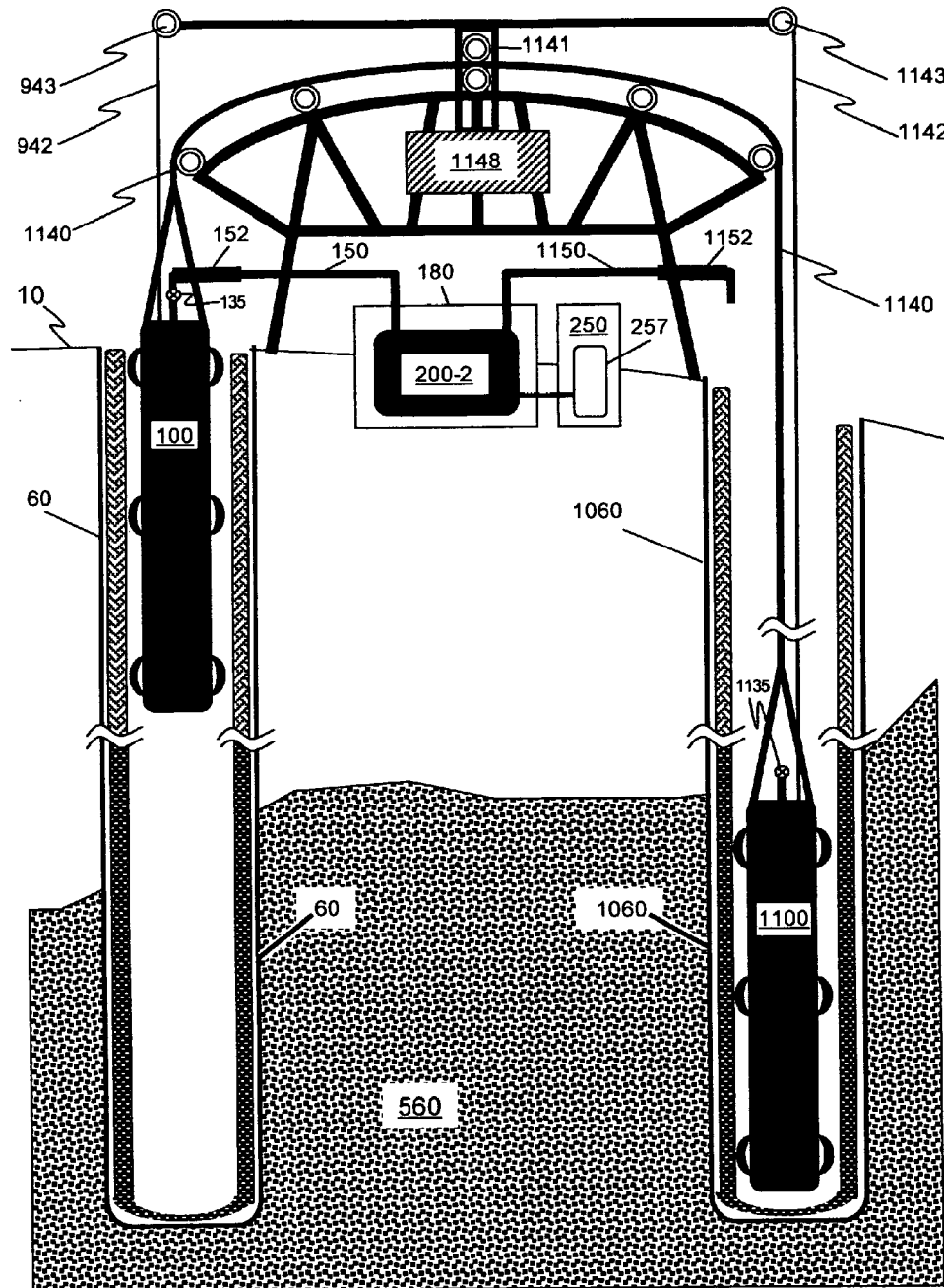

FIG. 17

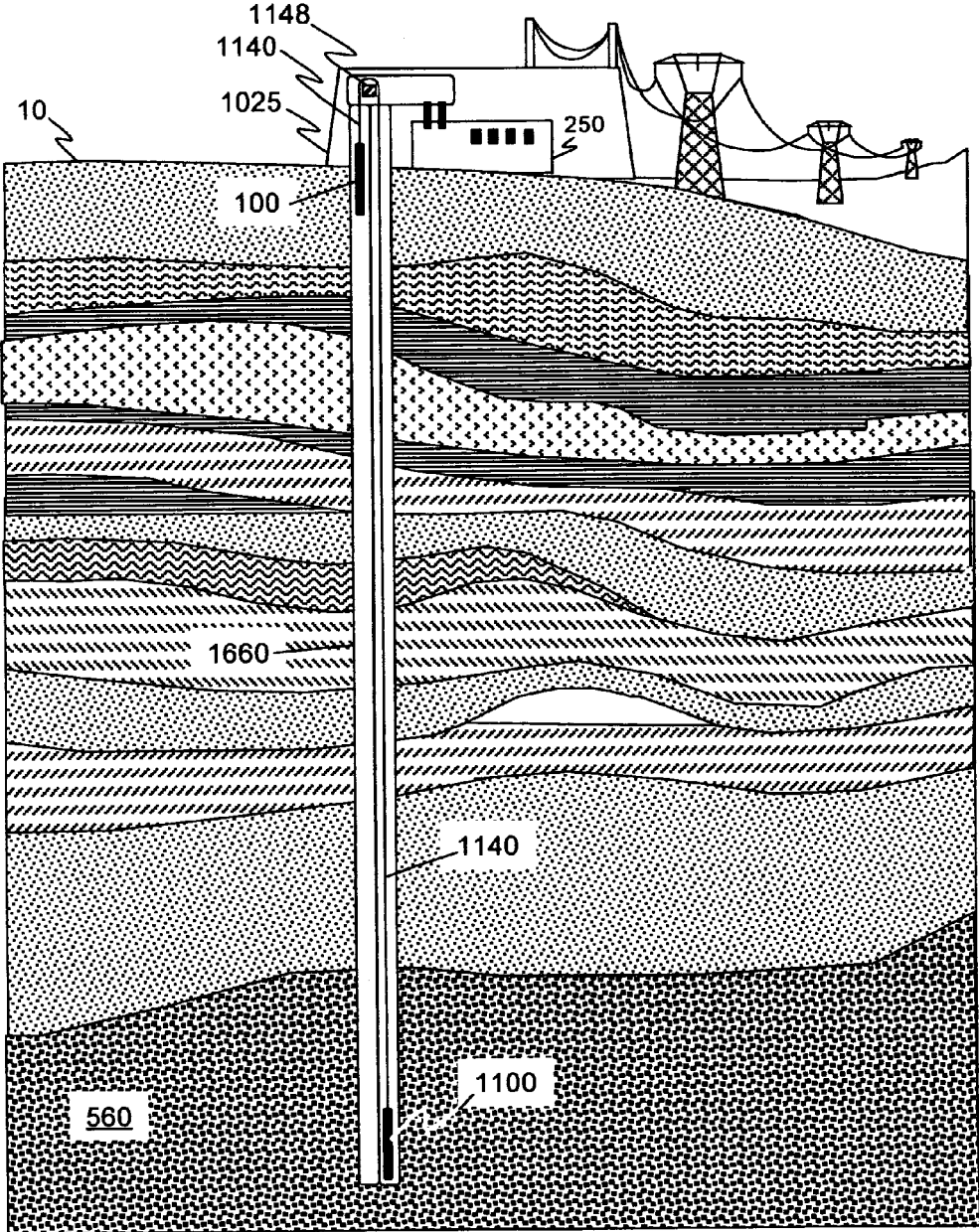

FIG. 18

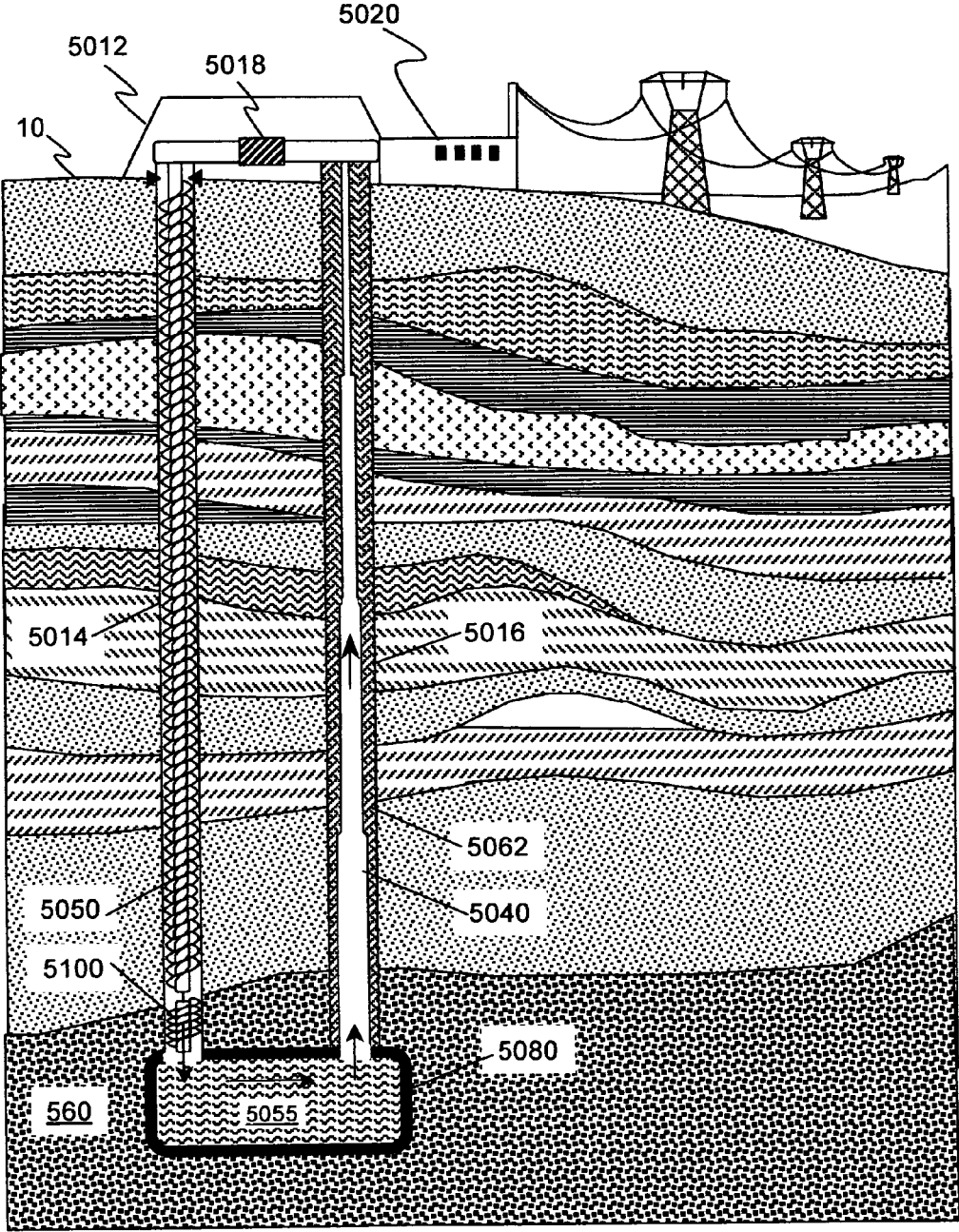

FIG. 19

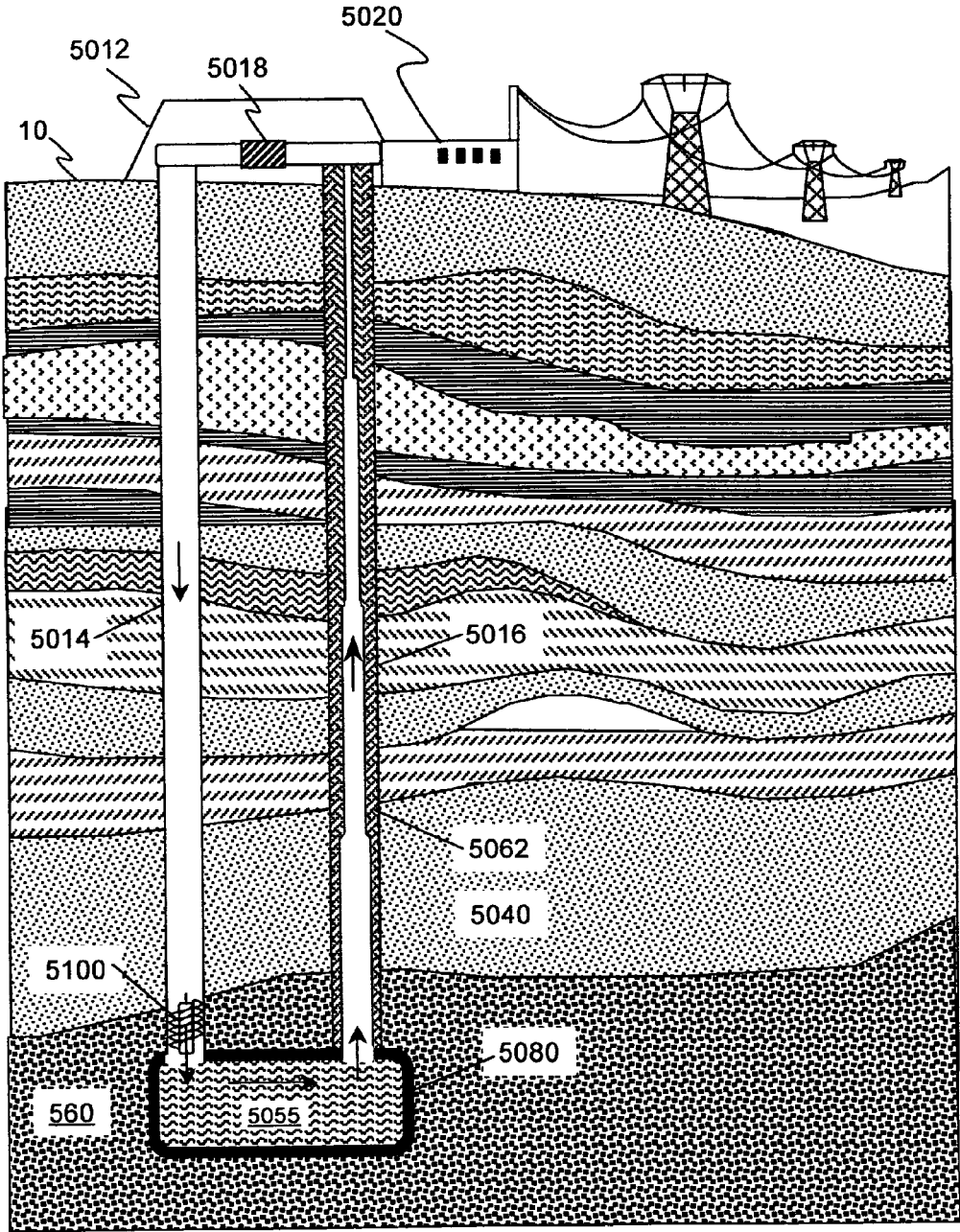

FIG. 20

## GEOTHERMAL ENERGY COLLECTION SYSTEM

### CROSS-REFERENCE TO RELATED APPLICATIONS

This application is a continuation of U.S. patent application Ser. No. 13/815,266, entitled "Geothermal energy collection system", and filed on Feb. 14, 2013, the contents of which is incorporated herein by reference in its entirety. U.S. patent application Ser. No. 13/815,266 further claims the benefit of U.S. Provisional Patent Application No. 61/633,756, filed on Feb. 17, 2012, the contents of which is incorporated herein by reference in its entirety.

### FIELD OF THE INVENTION

This invention relates to the field of geothermal energy extraction, and more specifically to the process of extracting heat from wells drilled into the Earth and using the extracted heat for an industrial process, such as the generation of electricity, or to drive a chemical or other manufacturing process.

### BACKGROUND OF THE INVENTION

Mankind has used geothermal energy for millennia. It is known that human tribes of the Neolithic Age bathed in natural hot springs, and the ancient Chinese and Roman civilizations built facilities to harness geothermal pools. With the core of the Earth believed to be over 5,000° C., it has been estimated that there is enough heat stored from the original formation of the Earth and generated by ongoing radioactive decay to meet mankind's energy needs for any foreseeable future.

The usual problems encountered in attempting to utilize geothermal energy have been practical ones of access, since the surface of the Earth is much cooler than the interior. The average geothermal gradient is about 25° C. for every kilometer of depth. This means that the temperature at the bottom of a well 5 km deep can be expected to be at a temperature of 125° C. or more. Oil companies now routinely drill for oil at these depths, and the technology required to create holes of this magnitude in the Earth is well known. (The deepest oil well at this time is over 12 km deep.) Wells of this depth, however, can be very expensive, costing over \$10M to drill.

However, near geological fault zones, fractures in the Earth's crust allow magma to come much closer to the surface. This gives rise to familiar geothermal landforms such as volcanoes, natural hot springs, and geysers. In the seismically active Long Valley Caldera of California, magma at a temperature more than 700° C. is believed to lie at a depth of only 6 km. Alternatively, if lower temperatures can be utilized, a well dug to a depth less than 1 km in a geothermal zone can achieve temperatures over 100° C. A well 1 km deep often can cost much less than \$1 M to drill.

Electricity generation from geothermal energy was first demonstrated in Italy in 1904, but it was only in the 1950s that the first commercial operations began. The initial approach, such as that used at the Geysers facilities in Sonoma and Lake Counties, Calif., relies on natural steam within the Earth. At the Geysers, wells about 1-2 km deep penetrate the cap rock into a stratum containing magma-heated steam at a temperature of about 170° C. and a pressure of about 700 kPa (about 7 atm). The naturally high-pressure steam pushes to the surface through the well,

and is directed to drive turbines to generate electricity. The water at the end is discarded as wastewater. (For more, see <<http://www.geysers.com/>>.)

A more ambitious multi-year project in Iceland, the Iceland Deep Drilling Project (IDDP) along the mid-Atlantic ridge plans to drill wells 5 km deep to tap into a source of 500° C. hot supercritical hydrous fluid at about 220 atm in pressure. (For more, see <<http://iddp.is/about/>>.)

Both of these projects tap into naturally existing geothermal pools of steam or superheated fluid. Such a system, often called a geothermal well, has its advantages in that the steam is naturally under pressure, and is replenished from a reservoir of groundwater. However, this technique can only be used in locations where there is magma nearer the surface to provide heat, where there is a steady supply of ground water to become pressurized steam, and a solid cap rock to keep the steam confined and under pressure. These conditions restrict the applicability of this method to relatively few geographic sites.

More recent methods to utilize geothermal energy in hot, dry rock are called enhanced geothermal systems, or EGS. [See "The Future of Geothermal Energy: Impact of Enhanced Geothermal Systems (EGS) on the United States in the 21<sup>st</sup> Century", MIT Report, 2006, available at [http://www1.eere.energy.gov/geothermal/egs\\_technology.html](http://www1.eere.energy.gov/geothermal/egs_technology.html).] In such a system all that is needed is for a pool of geothermal heat to exist at a depth where wells can be economically produced. In an EGS setup, a first well is drilled several kilometers deep and large volumes of water injected down into the hot rock. The water can be injected at temperatures that fracture the lower hot rock to make it more permeable. This process is called hydraulic fracturing, or "fracking". The water being pumped into the injection well is then heated below the surface to become steam, and pumped out in a second well. This method for generating electricity is therefore similar to the previously described traditional geothermal technique, except in EGS the water is supplied by the system. The spent water, once the heat has been extracted to generate electricity, is reinjected into the injection well.

FIG. 1 illustrates a prior art EGS system. At or near the surface of the Earth **10**, an EGS facility **12** provides a pumping system that injects water into the Earth and pumps water/steam from the Earth once heated. An injection well **14** extends into the Earth to a depth significantly hotter than the surface **10**. The region of the Earth at this hotter temperature is designated a thermal pool **560**. Water is then injected from the EGS facility **12** into the injection well **14**, where it disperses into the thermal pool **560**. Sometimes, the water is injected at such pressures that it causes a network of fractures **570** in the hot rock of the thermal pool **560**, making it more permeable to water, and increasing the surface area of the rock in order to heat the water more quickly. Once the water is heated in the thermal pool **560**, it is pumped out the production well **16**, either as superheated water or as supercritical steam. The heated water/steam is used to drive a production facility **20** to generate electricity.

EGS can be used anywhere there is a suitable stratum of hot rock at accessible depths, as long as there is a supply of water to initiate the process and to replenish what is lost. Because the water/steam brought to the surface is intended to be recaptured once the heat is extracted and re-injected into the injection well, this is called a closed loop system. It is proving a popular alternative for geothermal energy, notably because it can be used in far more geographic sites than traditional geothermal wells.

EGS geothermal energy production facilities are being developed by several companies, including AltaRock Energy, Inc. of Seattle, Wash. AltaRock Energy Inc. has several issued patents on their technology, such as U.S. Pat. No. 8,109,094 (SYSTEM AND METHOD FOR AQUIFER GEO-COOLING by S. Petty, filed Apr. 30, 2009 and issued Feb. 7, 2012); and U.S. Pat. No. 8,272,437 (ENHANCED GEOTHERMAL SYSTEMS AND RESERVOIR OPTIMIZATION by D. Bour and S. Petty, filed Jul. 7, 2009 and issued Sep. 25, 2012); and has several applications pending, such as U.S. patent application Ser. No. 12/432,306 (SYSTEM AND METHOD FOR USE OF PRESSURE ACTUATED COLLAPSING CAPSULES SUSPENDED IN A THERMALLY EXPANDING FLUID IN A SUBTERRANEAN CONTAINMENT SPACE by D. Bour, filed Apr. 29, 2009); Ser. No. 12/433,747 (METHOD AND COOLING SYSTEM FOR ELECTRIC SUBMERSIBLE PUMPS/MOTORS FOR USE IN GEOTHERMAL WELLS by S. Petty, filed Apr. 30, 2009); Ser. No. 12/538,673 (METHOD FOR TESTING AN ENGINEERED GEOTHERMAL SYSTEM USING ONE STIMULATED WELL by S. Petty, P. Rose and L. Nofziger, filed Aug. 10, 2009); Ser. No. 12/754,483 (METHOD FOR MODELING FRACTURE NETWORK, AND FRACTURE NETWORK GROWTH DURING STIMULATION IN SUBSURFACE FORMATIONS, by S. Petty, M. Clyne and T. Cladouhos, filed Apr. 5, 2010); Ser. No. 12/791,735 (SYSTEM AND METHOD FOR DETERMINING THE MOST FAVORABLE LOCATIONS FOR ENHANCED GEOTHERMAL SYSTEM APPLICATIONS, by S. Petty, O. Callahan, M. Clyne and T. Cladouhos, filed Jun. 1, 2010); Ser. No. 13/326,285 (HIGH TEMPERATURE TEMPORARY DIVERTER AND LOST CIRCULATION MATERIAL by D. Bour, L. Watters, S. Petty and A. Apblett, filed Dec. 14, 2011); and Ser. No. 13/342,924 (SYSTEM AND METHOD FOR AQUIFER GEO-COOLING by S. Petty, filed Jan. 3, 2012); which may be considered prior art for the invention disclosed in this application.

However, there are some drawbacks to such prior art systems using EGS. First, energy must be expended both to force water down into the injection well, and to pump the heated water/steam from within the Earth. Although the energy produced can still be significantly larger, it is an additional, ongoing cost. Second, EGS requires very large quantities of water to serve the needs of the injection well. In the western United States, the most likely area to deploy EGS because geothermal resources can be tapped with shallower wells, water is scarce and coveted resource. In those areas where sufficient water is available, additional problems arise due to the ultimate pollution of that water due to the minerals, salts and other toxic elements injection well water concentrates as it moves through the EGS cycle. Third, “fracking” in the Earth at the bottom of the injection well can release methane, contaminating groundwater, and creates seismic events, which can sometimes be felt at the surface as earthquakes. A recent EGS project in Switzerland was suspended and ultimately cancelled due to strong seismic events (including a magnitude 3.4 earthquake) in the nearby city of Basel triggered by the injection well [see, for example, Domenico Giardini, “Geothermal quake risks must be faced”, Nature Vol. 463, p. 293 (January 2010)].

FIG. 2 illustrates a prior art alternative approach to mining heat from dry hot rock as proposed by GTherm Inc. of Westport, Conn. In the prior art GTherm system, as in EGS, a surface facility **12-1** at the surface of the Earth **10** provides a pumping system **18-1** to inject water into the Earth through injection piping **14-1**, and to pump water/steam from the

Earth through production piping **16-1** once heated. However, in the GTherm system, a single well shaft **11-1** with a well head **15-1** extends into the Earth to the thermal pool **560**, and contains both the injection piping **14-1** and the production piping **16-1**. At the base of the well shaft, using underground drilling techniques such as potter drilling, developed by Potter Drilling Inc. of Redwood City, Calif. and described in part in U.S. Pat. No. 8,235,140 (METHOD AND APPARATUS FOR THERMAL DRILLING by T. Wideman, J. Potter, D. Dreesen and R. Potter, filed Oct. 8, 2009 and issued Aug. 7, 2012), a chamber **580** in the rock is formed surrounded by the thermal pool **560**, and them sealed with a coating **590** of a special proprietary grout. This chamber **580** with coating **590** forms what GTherm designates a “Heat Nest”.

Water is then injected through the injection piping **14-1** into the chamber **580** with coating **590**, creating a reservoir of liquid **550**. This liquid **550** heats up, and is then pumped out of the same well shaft **11-1** through the production piping **16-1**, either as superheated water or as steam. As in the previous EGS configuration, the heated water/steam is used to drive a production facility **20-1** to generate electricity.

This modified, single well EGS (SWEGS) closed loop approach of GTherm has some advantages over conventional EGS. First, once the heat nest has been formed, no fracturing of the bedrock need occur, meaning no seismic events will occur to disturb surface residents. Second, the water remains confined in the heat nest, and does not mix with local water sources or become contaminated with minerals or organic compounds from the local soil. Third, since the water used in the thermal loop does not mix with the local sources of groundwater, groundwater contamination does not occur unless there is damage or a leak to piping in the well shaft.

Several patent applications have been filed on this SWEGS technology, including U.S. patent application Ser. No. 12/456,434 (SYSTEM AND METHOD OF CAPTURING GEOTHERMAL HEAT FROM WITHIN A DRILLED WELL TO GENERATE ELECTRICITY by M. Parrella, and filed Jun. 15, 2009); and Ser. No. 12/462,656 (CONTROL SYSTEM TO MANAGE AND OPTIMIZE A GEOTHERMAL ELECTRIC GENERATION SYSTEM FROM ONE OR MORE WELLS THAT INDIVIDUALLY PRODUCE HEAT); Ser. No. 12/462,657 (SYSTEM AND METHOD OF MAXIMIZING HEAT TRANSFER AT THE BOTTOM OF A WELL USING HEAT CONDUCTIVE COMPONENTS AND A PREDICTIVE MODEL); Ser. No. 12/462,658 (SYSTEM AND METHOD OF MAXIMIZING GROUT HEAT CONDUCTIBILITY AND INCREASING CAUSTIC RESISTANCE); and Ser. No. 12/462,661 (SYSTEM AND METHOD OF MAXIMIZING PERFORMANCE OF A SOLID-STATE CLOSED LOOP WELL HEAT EXCHANGER), all by M. Parrella and filed Aug. 5, 2009.

Although the SWEGS variation does offer improvements over conventional EGS, it still uses water as the fluid to carry heat from the thermal pool to the surface. As illustrated in Table I, if the temperature in the thermal pool is below 100° C., liquid water has a large energy density, and can do an efficient job of bringing heat to the surface. Water has a specific heat of 4.187 kJ/(kg ° C.) and a density of 1,000 kg/m<sup>3</sup>, giving an appreciable energy density of 4,187 kJ/(m<sup>3</sup> ° C.). However, at a pressure of 1 atmosphere (1 atm, also 1.01 bar or 101 kPa) the temperature of liquid water is



at most 100° C., and therefore the amount of heat that can be raised with each kilogram of water is limited by its boiling point.

TABLE I

Specific Heat, typical Mass Density, and Energy Density of water, steam, and various other substances.			
Table I	Specific Heat kJ/ (kg ° C.)	Mass Density kg/m <sup>3</sup>	Energy Density kJ/ (m <sup>3</sup> ° C.)
Water (20° C.)	4.187	1,000	4,187
Superheated Water (161 atm, 350° C.)	8.138	579	4,712
Steam (1 atm, 100° C.)	2.027	0.59	1.2
Superheated Steam (10 atm 350° C.)	1.623	3.95	6.4
Uranium	0.120	19,100	1,292
Granite	0.790	2,700	2,133
Molten Salt (142-540° C.)	1.560	1,680	2,621
Aluminum (#6061)	1.256	2,710	3,404
Cast Iron	0.456	7,920	3,612
Stainless Steel (Grade 316)	0.502	8,027	4,030

## Sources:

Water: [http://www.engineeringtoolbox.com/water-thermal-properties-d\\_162.html](http://www.engineeringtoolbox.com/water-thermal-properties-d_162.html)  
 Supercritical Water: [www.isa.org/~birmi/magnetrol/Technical\\_Handbook.pdf](http://www.isa.org/~birmi/magnetrol/Technical_Handbook.pdf)  
 Steam: [http://www.thermexcel.com/english/tables/vap\\_eau.htm](http://www.thermexcel.com/english/tables/vap_eau.htm)  
 Superheated Steam: [http://www.spiraxsarco.com/esc/SH\\_Properties.aspx](http://www.spiraxsarco.com/esc/SH_Properties.aspx)  
 Salt/Aluminum: [http://www.engineeringtoolbox.com/sensible-heat-storage-d\\_1217.html](http://www.engineeringtoolbox.com/sensible-heat-storage-d_1217.html)  
 Steel: [http://www.engineersedge.com/properties\\_of\\_metals.htm](http://www.engineersedge.com/properties_of_metals.htm)

Water can be superheated under pressure, and can have a boiling point as high as 374° C. under a pressure of 214 atm. Table I also shows the energy density achievable for water superheated to 350° C. If the production well is suitably airtight and pressurized, higher temperatures can be maintained, and with the greater temperature increase, significantly more heat can be pumped to the surface when superheated water is used. However, such high-pressure plumbing systems for a well several kilometers below the surface can be difficult to maintain. Also, superheated water can be a much better solvent for larger organic compounds, particularly if they have some polar groups or contain aromatic compounds, increasing the risk of contamination in the system. Therefore, superheated water can be more corrosive than water at ordinary temperatures, and at temperatures above 300° C. special corrosion resistant alloys may be required for the well casing, depending on the composition of the dissolved components.

An alternative to using superheated water is to allow the water underground to boil and become steam. Extreme pressures need not be maintained to control the flow of the steam at temperatures that can be significantly hotter than 100° C. But, as shown in Table I, the energy density of steam is significantly lower than liquid water. Even though the specific heat (2.027 kJ/(kg ° C.)) is smaller by only a factor of 2, the much lower density (typically 0.6 kg/m<sup>3</sup>) of normal steam means the same volume of steam holds 3,500 times less heat than liquid water. Supercritical heating of steam, increasing the temperature and pressure, can increase the volumetric energy density somewhat, but typically not by more than a factor of 10, and then the problems of managing an extremely hot fluid under pressure are reintroduced.

Table I also compares the energy density possible with water and steam with a few other materials, notably molten salt (heated above 142° C.) and several metals. These support an energy density much higher than that of steam for cases where the thermal pool is hotter than 100° C., especially for the case of stainless steel, where the energy density approaches water again.

There is therefore a need for a geothermal system which can operate as a closed loop system without causing seismic damage or groundwater contamination, but which also allows for a substance with a large volumetric energy density to be used to absorb heat inside the Earth from depths where the temperature is greater than 100° C., coupled with an efficient means to bring the heated substance to the surface of the Earth for thermal harvesting.

## BRIEF SUMMARY OF THE INVENTION

The invention disclosed with this application is a method of extracting energy from the Earth. There are many embodiments of the invention disclosed here. Several embodiments of the invention comprise the insertion of a thermal mass into a Heat Absorption Zone, having the thermal mass absorb heat while in the Heat Absorption Zone, raising the thermal mass to a Heat Transfer Zone, and transferring the heat from the thermal mass.

In some embodiments of the invention, the thermal mass comprises internal chambers filled with a liquid thermal absorber such as molten salt, and the transfer of heat comprises transferring the heated liquid thermal absorber out of the thermal mass.

In some embodiments of the invention, the thermal mass comprises structures to facilitate heat exchange with a thermal exchange fluid, and the transfer of heat comprises flowing an exchange fluid through the thermal mass

In some embodiments of the invention, the thermal mass is balanced with a counterweight. In some embodiments of the invention, the counterweight is another thermal mass.

In some embodiments of the invention, the heat transferred from the thermal mass can be utilized for a number of possible industrial processes, including generating electricity.

In some embodiments of the invention, a solid material, such as a salt mixture, is transported into a Heat Absorption Zone, where it absorbs heat and melts. The hotter melted material is then raised to a Heat Transfer Zone, and the heat is transferred from the material and used to drive a number of possible industrial processes, including generating electricity.

## BRIEF DESCRIPTION OF THE DRAWINGS

FIG. 1 presents a schematic overview of an example of prior art enhanced geothermal systems (EGS) for geothermal energy extraction.

FIG. 2 presents a schematic overview of a prior art single-well enhanced geothermal system (SWEGS) using a thermal nest for geothermal energy extraction.

FIG. 3 presents a flow diagram of the thermal extraction process according to several embodiments of the invention.

FIG. 4 presents a schematic overview of one embodiment of the invention.

FIG. 5 presents in more detail a cross section view of an embodiment of the invention in which a thermal mass is being heated.

FIG. 6 presents in more detail a cross section view of the embodiment of the invention shown in FIG. 5 in which the thermal mass has been raised to the surface and heat is being transferred from thermal mass to a thermal reservoir.

FIG. 7 presents a cross section view of an embodiment of the invention that uses a thermal fluid to transfer the heat from the thermal mass.

FIG. 8 presents an external shell for a thermal mass according to the invention.

FIG. 9 presents the internal and top parts of a thermal mass according to a first embodiment of the invention.

FIG. 10 presents a mechanism for mechanical support of the thermal mass according to the invention.

FIG. 11 presents a cross section view of an embodiment of the invention that uses a thermal exchange fluid to transfer the heat from the thermal mass.

FIG. 12 presents the internal and top parts of a thermal mass according to a second embodiment of the invention.

FIG. 13 presents the internal and top parts of a thermal mass according to a variation of the second embodiment of the invention.

FIG. 14 presents a flow diagram of the first part of a process according to an embodiment of the invention in which two thermal masses are used.

FIG. 15 presents a flow diagram of the second part of a process according to an embodiment of the invention in which two thermal masses are used.

FIG. 16 presents a schematic overview of an embodiment of the invention in which two thermal masses are used.

FIG. 17 presents in more detail a cross section view of the embodiment of the invention shown in FIG. 16 in which two thermal masses are used.

FIG. 18 presents a schematic overview of an embodiment of the invention in which two thermal masses are used in the same well.

FIG. 19 presents a schematic overview of an embodiment of the invention using a closed loop for a thermal substance and comprising a screw along the length of the injection well.

FIG. 20 presents a schematic overview of an embodiment of the invention using a closed loop for a thermal substance and comprising a ram screw in the Heat Absorption Zone.

Note that the illustrations provided are for the purpose of illustrating how to make and use the invention, and are not to scale. The wells are anticipated to be kilometers deep, while the thermal masses are expected to be typically 50 centimeters to 30 meters long and from 10 to 100 centimeters in diameter, and can be scaled to be other sizes and shapes if desired.

#### DETAILED DESCRIPTIONS OF EMBODIMENTS OF THE INVENTION

What follows are detailed descriptions of several embodiments of the invention, including embodiments believed by the inventor to be the best mode.

Common to many embodiments of the invention are the steps illustrated in the flow diagram of FIG. 3 and the overview illustration shown in FIG. 4. To start, as shown in FIG. 3, the initial step 2000 comprises digging a well shaft 60 into the Earth, until a portion of the well shaft 60 is surrounded by a thermal pool 560. It should be noted that some embodiments of the invention could be implemented in a pre-existing well, so that a new well shaft 60 need not be dug for each installation.

In the second step 2100, a thermal mass 100 is then prepared with a procedure that typically comprises attaching it to a suspension cable 140 which in turn is attached to a control system 148 for raising and lowering the thermal mass 100. Once the thermal mass has been prepared, in the next step 2200 the thermal mass 100 is then lowered down the well shaft 60 until it reaches the thermal pool 560. This region is designated the Heat Absorption Zone. The next step 2300 comprises allowing the thermal mass 100 to remain in the Heat Absorption Zone until a desired temperature is reached or a predetermined amount of heat has

been absorbed by the thermal mass 100. The illustration in FIG. 4 represents the process at this point.

After this, the next step 2400 comprises raising the heated thermal mass 100 to an area designated the Heat Transfer Zone, typically near the surface of the Earth 10. The next step 2500 comprises extracting the heat energy from the thermal mass 100 and transferring it to a thermal reservoir 200. After this, the thermal mass 100 can be prepared again according to a repetition of the second step 2100 and the subsequent steps 2200 through 2500 repeated, and the cycle continues.

At the same time, according to alternative step 2800, the heat energy transferred into the thermal reservoir 200 can be used in a production facility 250 for a number of useful processes, such as generating electricity, driving another industrial process such as pyrolysis, or simply being stored for later use. A housing 25 or other structure to protect the well shaft 60 from the elements can also be constructed, either independent of, or in connection with the production facility 250.

For the purposes of this description, the term "thermal mass" can be any discrete object, whether it be solid, hollow, liquid filled, etc. that has a mass and a heat capacity and is prepared for insertion into the thermal well. It can be a simple slug of metal, chosen for its heat capacity, or a more complex structure with internal mechanisms, piping and structures, and may additionally comprise reservoirs of fluids and plumbing to facilitate the transfer of heat by the transfer of fluids into and out of the thermal mass. It may also contain chambers or other structures to facilitate an internal chemical process.

The preparation of the thermal mass can be a procedure as simple as attaching it to a cable for suspension. However, if there are more complex internal structures, such as internal piping and reservoirs, the preparation can also comprise checking the temperatures, pressures, fill levels and purity of fluids in the chambers, the distribution of mass, making an exchange of fluids needing replacing, confirming the condition of the seals on the valves and connectors, corrosion, inspection for cracks or other damage on the external shell or the suspension cables, determining the security of any hoses and seals, the calibration of any gauges or data sensors, etc.

For the purposes of this description, the term "thermal pool" refers to a portion of the Earth underground that is significantly hotter than at the surface, and which therefore provides a source of energy. Although the thermal pool as described in the embodiments of the invention disclosed here will generally be a stratum of hot dry rock as might be used in the prior art EGS configurations, these embodiments may also be applied to any geothermal heat source, including to wells which extend deep enough to encounter molten rock or magma within the Earth.

For the purposes of this description, the term "thermal well" refers to the Heat Absorption Zone, and describes a structure created in the Earth, typically by drilling a hole, in which at least a portion of the structure, typically the bottom, is in the thermal pool, and is therefore naturally at a significantly hotter temperature than is found on the surface of the Earth. When an object, such as the thermal mass, is inserted into the thermal well and left there, the object heats up as it is surrounded by the thermal pool.

#### A First Embodiment of the Invention

One embodiment of the invention is illustrated in more detail in FIG. 5 and FIG. 6. Note that these illustrations are

not to scale, since the wells are anticipated to be kilometers deep while the thermal masses are expected to be, for example, 1 to 30 meters long and perhaps 50 to 100 centimeters in diameter.

In this embodiment of the invention, the deeper part of the well shaft **60** surrounded by the thermal pool **560**, can be lined with a thermal casing **64** that facilitates the transfer of heat from the thermal pool **560** to the thermal mass **100**. This thermal casing can be made using a material such as a thermally conducting grout, often made from compositions comprising water, cement, siliceous gel, and sometimes bentonite. Additional materials such as iron filings or other metallic powders can be mixed into the grout to enhance thermal conductivity. The surface can also be treated to be smooth to increase emissivity for enhancing radiative heat transfer. Although the well shaft as shown is a simple vertical hole, the well shaft can have more complex structures such as varying diameters, chambers situated at various positions along the shaft, or side tunnels.

Likewise, the upper part of the well shaft **60**, which is at cooler temperatures, can be lined with an insulating casing **62** that prevents heat from the thermal mass **100** from dissipating before it reaches the top of the well shaft **60**. This insulating casing can be made using a material such as solid concrete, porous concrete, tubing walls of  $\frac{3}{8}$ " thick stainless steel, or a layered structure of concrete and steel. For insulation in high heat situations, a weave of basalt fabrics such as those manufactured by Smarter Building Systems of Newport, R.I. may provide an adequate insulating casing. Other fiber products comprising ceramic or silica materials can also be used.

The system also comprises suspension mechanism such as a suspension cable **140** or other suspension rigging that suspends the thermal mass **100** in the well shaft **60**. The suspension cable **140** can be attached to a suspension mechanism **141** for raising and lowering the suspension cable **140** and the attached thermal mass **100**, which in turn is managed by a control system **148**. The system can also comprise an additional communication cable **142** with a data connector **132** to sensors in the thermal mass **100** that provide data about variables of interest such as temperature, thermal expansion, distribution of mass, etc. This communication cable **142** can be managed using independent mechanism **143** that winds and unwinds the communication cable **142** as the thermal mass **100** is lowered and raised. In some embodiments, the communication cable can instead be integrated into the suspension cable **140**, and raised and lowered using the suspension mechanism **141**. A housing **25** can be provided to protect the machinery for raising and lowering the thermal mass **100** from the elements.

In some embodiments of the invention, a thermal transfer system in the Heat Transfer Zone will also be provided to unload the heat in the thermal mass **100**. In some embodiments, heated fluid from the thermal mass **100** is transferred through a thermal transfer conduit **150**, which can in some embodiments have a moving or telescoping junction **152** to connect with the thermal mass **100** using a thermal fluid connector **135**. The heated fluid is then transferred to a thermal reservoir **200** contained in a thermal reservoir containment **180**. The heat in the thermal reservoir **200** is then used to generate electricity or drive an industrial process in a production facility **250**, which can comprise a means for generating electricity **257** or other production equipment.

In some embodiments of the invention, the heat can be transferred by detaching the thermal mass **100** from the suspension cable **140** and placing the hot thermal mass **100**

into a thermal reservoir **200** for subsequent thermal transfer. If the thermal mass **100** is designed as a simple slug of metal with a large heat capacity, this transfer can comprise placing the hot thermal mass into a fluid bath in the thermal reservoir **200**, in which the heat is transferred from the thermal mass to the fluid in the bath. If the thermal mass **100** is a metallic structure with more complex internal structures, such as internal tubes that facilitate fluid flow for heat transfer through the thermal mass **100**, the thermal mass **100** can be attached to a plumbing system that provides fluid that removes the heat from the inside of the thermal mass **100** as it passes through the various internal tubes.

In the meantime, while the initial thermal mass **100** is transferring heat in the Heat Transfer Zone, an alternate thermal mass, which will typically be an object with dimensions and a construction similar to the initial thermal mass **100**, can be attached to the suspension cable **140** and lowered into the well shaft **60** to begin heating in the Heat Absorption Zone.

FIG. 7 provides a more detailed illustration of one embodiment of the invention. For this embodiment, the thermal mass **100** comprises a hollow cavity, typically cylindrical in shape, which is filled to a predetermined level with a thermal fluid **55**. The fluid can be liquid water if used in a relatively cool well below 100° C.; or a molten salt or combination of salts, such as, for example, CN—K (Potassium Calcium Nitrate—KNO<sub>3</sub> 5 Ca(NO<sub>3</sub>)<sub>2</sub> 10 H<sub>2</sub>O) as offered by Yara International ASA of Norway for warmer wells, (e.g., 150° C. to 500° C.); or, for higher temperatures (e.g., 300° C. to 1000° C.) a molten salt mixture such as one comprising by weight 50% Potassium Nitrate (KNO<sub>3</sub>), 40% Sodium Nitrite (NaNO<sub>2</sub>) and 7% Sodium Nitrate (NaNO<sub>3</sub>). Other mixtures of salts can be used, comprising salts such as sodium fluoride (NaF), sodium chloride (NaCl), potassium fluoride (KF), potassium chloride (KCl) (which melt at even higher temperatures) as long as their proportions are managed to provide an appropriate thermal and fluid properties for the temperature of the thermal pool **560**. Mixtures of molten salts used for energy storage and transport in the concentrated solar power (CSP) facilities may also be adapted for use in the embodiments of the invention disclosed here.

During the preparation of the thermal mass **100**, the hollow interior of the thermal mass **100** is provided with thermal fluid **55** from a cool thermal fluid reservoir **202** which will typically contain previously cooled fluid **55-C**. This cool thermal fluid reservoir **202** will typically be constructed in the thermal reservoir containment **180**, which also contains the thermal reservoir **200** for heated thermal fluid **55-H**. The filling process for the thermal mass **100** can be controlled by a pumping system **155** through a valve on the cool thermal fluid reservoir **202** and a valve **185** that switches the pumping system **155** between the cool thermal fluid reservoir **202** and the thermal reservoir **200**. The fluid **55** is provided to the thermal mass **100** through thermal transfer conduit **150** through the moving or telescoping junction **152** which connects to the thermal mass **100** at the thermal fluid connector **135**. The thermal mass **100** in some embodiments will comprise an interior transfer tube **115** connected to the thermal fluid connector **135** that extends to near the bottom of the reservoir within thermal mass.

Since hot fluids, and in particular a molten salt system, can degrade rapidly when exposed to air, and additionally can be corrosive and dangerous, it may be advisable to seal the thermal fluid from exposure to the ambient environment. In that case, there can be an additional system to provide a cover gas **56** compatible with the thermal fluid **55** to allow

fluid levels to vary without venting the system to outside air. Such a cover gas system would include a cover gas manager **160**, comprising a cover gas reservoir **165** and a cover gas pumping system **162** to provide cover gas **56** to the thermal mass **100** through a valve **163** and piping **164**, which connects to the thermal mass **100** at a cover gas connector **136**, or to provide cover gas **56** to the thermal reservoir containment **180** through a valve **167** and piping **168**.

The thermal mass **100** may also comprise sensors such as a temperature sensor **122** connected to an internal data cable **123** that connects at a data connector **132** to the communication cable **142**. The selection of the exact materials used in the temperature sensor **122** may be different, depending on the selection of thermal fluid **55** and the temperature increases expected. In particular, any sensors that are used must be able to operate at the heightened temperatures expected to be found in the thermal pool **560**, which may routinely exceed  $500^{\circ}\text{C}$ . and may in some embodiments be nearly as hot as molten magma. For lower temperature thermal pools **560**, conventional thermocouples may be employed in the temperature sensor **122**. For embodiments with high temperatures, many metals melt, and sensors comprising complex circuits can no longer function. For these situations, simpler systems such as a platinum resistance thermometer may be employed as the temperature sensor **122**. For extremely hot temperatures, a dual metal (two component) thermostat may be employed, simply making electrical contact to close a circuit once a predetermined calibrated temperature has been reached. Other temperature sensor options may be known to those skilled in the art.

The thermal mass may also comprise other sensors, including but not restricted to motion sensors, accelerometers, acoustic sensors, optical sensors, infrared sensors, fluorescence sensors, pressure sensors, and sensors for temperature gradients. The connections for the various sensors can be through electrical wires to the communications cable **142**, through a fiber optic connector, or through wireless transceivers. The only major consideration limiting selection among these various options is their ability to function under the temperature conditions found when the thermal mass **100** has been immersed in the thermal pool **560**.

Once the thermal mass **100** has been heated in the thermal pool **560** and returned to the Heat Transfer Zone, the moving or telescoping junction **152** can be joined at the thermal fluid connector **135** to the internal transfer tube **115** within the thermal mass **100**. The internal transfer tube **115** provides a means of evacuating the thermal fluid **55** from the thermal mass **100** through the thermal transfer conduit **150**, which can also comprise a pumping system **155** to pump the thermal fluid **55** from the thermal mass **100** into the thermal reservoir **200**. This pumping system **155** and conduit **150** can be the same pumping system and conduit previously used to fill the thermal mass, or in some embodiments separate pumping systems and conduits may be designed to provide an alternative flow channel. A valve **175** controls the flow of thermal fluid into the thermal reservoir through valve **185**, which can be closed once the transfer has been completed. In some embodiments, the thermal transfer conduit **150** and components of the pumping system **155** as well as other components in contact with the thermal fluid may be coated with a suitable material such as Nichrome to prevent corrosion.

Once transferred to the thermal reservoir **200**, the hot thermal fluid **55-H** in the thermal reservoir **200** can then be used to generate electricity or drive another industrial process such as pyrolysis in a production facility **250**, which can

comprise a means for generating electricity **257** or some other production equipment. Once its heat has been extracted and used, the cooled thermal fluid **55-C** can be returned to a cool thermal fluid reservoir **202**, where it serves as a source of thermal fluid **55** for refilling the thermal mass **100**.

FIG. **8** shows an example of one embodiment for the external parts of an assembly for a thermal mass **100**. The exterior shell **101** in this example is a cylindrical tube, sealed at the bottom, and can be manufactured from a chromium alloy steel such as duplex SAE grade 2205 stainless steel if the thermal mass is to be used at temperatures lower than  $300^{\circ}\text{C}$ ., while a corrosion resistant steel also containing molybdenum such as SAE grade 254SMO can be used for hotter temperatures. The thickness may vary depending on the overall weight and design considerations, but it is expected that a thickness of 1 cm ( $\frac{3}{8}$ " or larger for the wall thickness will be typical. The thermal mass **100** is also expected to typically be as large as 1 meter in diameter, and may be as long as 30 meters. The inner and/or outer surface of the exterior shell **101** can also be coated with an alloy such as nichrome to help prevent corrosion.

To facilitate centering in the well shaft **60**, the outside of the cylindrical shell may be provided with several spacers **103** designed to be able to bump against the side of the well as the thermal mass **100** descends and ascends. The spacers **103** can be simple metallic structures acting as springs welded onto the side of the exterior shell **101**, or can be more complex structures, comprising rollers or other mechanisms designed to reduce the friction with the wall of the well shaft **60**.

The bottom of the exterior shell **101** can comprise structures **108** such as a ring or a flange that provide a means for supporting the bottom of the thermal mass **100** such as apertures **105** for attaching cables. These structures **108** may be welded to the exterior shell **101**, held by means of a threaded grooves cut into the side of the exterior shell **101**, or attached by some other means known to those skilled in the art. The top of the exterior shell **101** may comprise a shell flange **109** comprising a number of apertures **102** that can be used to seal the top of the thermal mass **100** using a sealing method such as a stainless steel O-ring, in which the shell flange **109** is bolted to a mating top flange through the apertures **102** in a manner that crushes the O-ring, making a seal. The only requirement is that this sealing method be able to withstand the temperatures and pressures that the thermal mass **100** will be subjected to in the thermal pool **560**.

FIG. **9** shows the complementary part of the thermal mass **100**, comprising the top flange **110** and also several internal structures. The top flange **110** is designed to be mated to the shell flange **109** shown in FIG. **8**, with apertures **112** in the top flange **110** aligned with the apertures **102** in the shell flange **109**.

As shown in FIG. **9**, the top flange **110** is larger in diameter than shell flange **109**, and additionally comprises apertures **114** that provide a means of suspending the top of the thermal mass **100** from the suspension cable **140**.

As shown in FIG. **9**, the top flange **110** also comprises the various feedthroughs that connect the thermal mass **100** to various systems. The thermal fluid connector **135** is attached to the internal transfer tube **115** and is designed to mate with the moving or telescoping junction **152** to transfer the thermal fluid **55** into and out of the thermal mass **100**. The cover gas connector **136** is attached to an internal cover gas tube **116** and is designed to mate with the piping **164** that provides cover gas **56** from the cover gas manager **160**. The

13

data connector 132 is attached to an internal data cable 123 that connects to internal sensors, such as a temperature sensor 122, and is designed to mate with the communication cable 142 that provides information about the thermal mass 100 to the control system 148.

As shown in FIG. 9, the internal structures can also comprise internal spacers 113 that hold the various internal elements such as the internal transfer tube 115 for thermal fluid and the internal data cable 123 in place. The internal structures can also comprise a shoe 125 at the bottom of the internal transfer tube 115 that adjusts the flow direction of the thermal fluid 55 as it enters and exits the thermal mass 100.

FIG. 10 shows one embodiment of the invention in which the assembled thermal mass 100 has been suspended from the suspension cable 140. In this illustration, the suspension cable 140 is split at the coupling mechanism 138 into eight smaller suspension cables 144, each with attachment mechanisms 145 such as hooks or fasteners. In the embodiment of FIG. 10, four of these cables 144-U are shorter, and attach to four of the apertures 114 in the top flange 110 using hooks 145-U. The other four cables 144-L are longer, and pass through the other apertures 114 in the top flange 110 and extend to the apertures 105 in the structures 108 attached to the lower portion of the thermal mass exterior shell 101 using hooks 145-L.

Although FIG. 10 presents one embodiment for suspending the thermal mass 100, it will be clear to those skilled in the art that several different suspension mechanisms can be devised which will still conform with the embodiments of the invention as described in this section. In one embodiment, a web of cables can support the thermal mass at a plurality of points. In one embodiment, the thermal mass can be contained in a net of cables that is suspended from the suspension cable 140. In one embodiment, the spacers 103 can be integrated into the suspension system to provide additional points of attachment for the smaller suspension cables 144 that merge to form the suspension cable 140. In other embodiments, the thermal mass itself may comprise steel rods or attachment mechanisms designed to mate with one or more attachment mechanisms, such as hooks, suspended from the suspension cable 140.

It will also be clear to those skilled in the art that the illustration in FIG. 10 is not necessarily to scale. The thermal mass can, for example, have a diameter as small as 1 cm or as large as 1 meter, as well as a length as small as 25 centimeters or as large as 30 meters or even larger, depending on the size and scale of the well and the lifting mechanism. It will also be clear to those skilled in the art that some embodiments of the invention may be engineered in which the thermal mass is more aerodynamically streamlined than illustrated in FIG. 10. A more streamlined design will reduce air drag on the thermal mass 100 as it is lowered into or hauled out of the well shaft 60, accelerating the energy transfer process.

It should also be noted that, although we have described this embodiment as using a cable as the mean of suspension, it will be known to those skilled in the art that ropes, chains, cords, wires, fabrics, fibers, nets, and other means of suspension can be used to support the thermal masses.

#### A Second Embodiment of the Invention

FIG. 11, FIG. 12 and FIG. 13 show an alternative embodiment of the invention. In this embodiment, as in the first embodiment, a well shaft 60 can be dug to a thermal pool 560. As before, the well shaft 60 can be lined with various

14

casings, such as an insulating casing 62 in the upper portions of the shaft and a thermal casing 64 in the lower portion of the shaft. As before, a thermal mass 100-2 is lowered on a suspension cable 140 to a Heat Absorption Zone, heated by the thermal pool 560. After heating, the thermal mass 100-2 is then raised to a Heat transfer Zone near the surface of the Earth 10, and the heat unloaded into a thermal reservoir 300 contained in a thermal reservoir containment 380. The thermal mass 100-2 again comprises a cylindrical exterior shell 101, which can be the same design as was illustrated for the previous embodiment in FIG. 8, and can also have an interior cavity containing a thermal fluid 55 covered with a cover gas 56.

However, in this embodiment, the thermal fluid 55 remains in the thermal mass 100-2, and the thermal mass 100-2 is designed with an internal channel comprising internal piping 333 designed to have a significant surface area in contact with the thermal fluid 55. The internal piping 333 facilitates the flow of a thermal transfer fluid 35 from a thermal reservoir containment 380 containing a thermal reservoir 300. The thermal transfer fluid absorbs heat as it flows through the internal piping 333 of the thermal mass 100-2. The thermal transfer fluid 35 can be a liquid, such as water, or one of many glycol-based fluids such as DOW-THERM™ (from Dow Chemical Company of Midland, Mich.), or be selected from a variety of proprietary fluids such as Duratherm S (offered for sale by Duratherm Extended Life Fluids of Lewiston, N.Y.) or Dynalene HT (offered for sale by Dynalene Inc. of Whitehall, Pa.); or be a molten salt mixture such as CN—K (Potassium Calcium Nitrate—KNO<sub>3</sub>, 5 Ca(NO<sub>3</sub>)<sub>2</sub>, 10 H<sub>2</sub>O) (offered for sale by Yara International ASA of Norway), or conventional molten salts comprising various mixtures of nitrates and nitrides used in the concentrated solar power (CSP) industry. The exchange fluid can also be a gas, such as nitrogen, argon, helium, or compressed carbon dioxide.

After the thermal mass 100-2 has been warmed in the thermal pool 560 and brought back to the surface, the internal piping 333 can be attached using intake junction 338 to the thermal transfer fluid input conduit 350 and outflow junction 339 to the outflow conduit 352. A pumping system 355 facilitates the transfer of the thermal transfer fluid 35 through the thermal mass 100-2 to the thermal reservoir 300 through export valve 389. The heated thermal transfer fluid 35-H in the thermal reservoir 300 can then be used to generate electricity or drive another industrial process such as pyrolysis in a production facility 250, which can comprise a means for generating electricity 257 or some other production equipment. Once its heat has been extracted and used, the cooled thermal transfer fluid 35-C can be returned to a cool thermal fluid reservoir 302, where it serves as a source of thermal fluid 35 for refilling the thermal mass 100-2.

FIG. 12 shows an example of one embodiment for the internal parts of an assembly for a thermal mass 100-2 designed to use a thermal transfer fluid 35. As in the previously described embodiment, a top flange 310 has been designed to mate with shell flange 109, and apertures 312 in top flange 310 are designed to correspond to the apertures 102 in shell flange 109 for sealing using a sealing method such as a stainless steel O-ring, as described in a previous embodiment.

However, in this embodiment, the top of the thermal mass 100-2 will comprise an intake junction 338 where thermal transfer fluid 35 enters the internal piping 333 of the thermal mass 100-2. The thermal transfer fluid heats up as it flows through the internal piping 333, which in this illustration is

shown as a double helix structure. Heated thermal transfer fluid **35** then flows out of an outflow junction **339** where the thermal transfer fluid exits the internal piping **333** of thermal mass **100-2**.

FIG. **13** shows an additional example of one embodiment for the internal parts of an assembly for a thermal mass **100-2** designed to use a thermal transfer fluid. As in the embodiment illustrated in FIG. **12**, the thermal mass **100-2** comprises internal piping **433** to facilitate heat transfer, and comprises a top flange **310** that has been designed to mate with shell flange **109**, and apertures **312** in the top flange **310** are designed to correspond to the apertures **102** in shell flange **109** for sealing using a sealing method such as a stainless steel O-ring, as described in a previous embodiment.

As in the embodiment of FIG. **12**, thermal exchange fluid will be provided to the thermal mass **100-2** through an intake junction **438** where thermal transfer fluid enters the internal piping **433** of the thermal mass **100-2**. The thermal transfer fluid heats up as it flows through the internal piping **433**, but in this case the piping comprises a straight inflow pipe directly to the bottom of the thermal mass **100-2**, and a helical return path to the top. The heated thermal transfer fluid **35** flows out through an outflow junction **439** where the thermal transfer fluid exits the internal piping **433** of thermal mass **100-2**.

Note that, although a temperature sensor can be used in this embodiment to monitor the thermal mass, it is not expected that a temperature sensor inside the thermal mass is necessary for these embodiments of the invention. Instead, the temperature of the thermal exchange fluid **35** can be monitored as the heat is transferred.

It should also be noted that one possible variation on this embodiment has no thermal fluid **55** filling the thermal mass. Instead, the thermal mass **100-3** is simply filled with a solid material having a large heat capacity, such as granite, iron or stainless steel surrounding the internal piping **333**. The solid material can be a cast solid, such as cast iron, or an ensemble of solid objects such as granite sand or small ball bearings.

It should also be clear that, although internal channels comprising piping in the form of a helix or a double helix have been illustrated, other configurations are also possible. Channels normally used in heat exchangers, such as a serpentine form in which the piping forms a zigzag pattern, or a conventional spiral coil can also be used. Likewise, it should also be noted that the connections to the internal channel, although shown as separate connectors in FIG. **12** and FIG. **13**, could be designed as a single connector that can accommodate both the insertion and the removal of the thermal exchange fluid.

#### A Third Embodiment of the Invention

In the previously described embodiments, the thermal mass can be lowered into the thermal well and then raised once it has acquired heat. However, for a single thermal mass raised into a single thermal well, significant energy must be expended to raise the thermal mass against the pull of gravity. This may place a practical limit on the mass that can be used, since a thermal mass that is heavier will require more energy to raise, especially when the wells are at depths of kilometers. However, heavier masses may be advantageous from a thermal energy point of view, in that heavier, denser thermal masses can have a significantly larger heat capacity, and therefore acquire more heat to be harvested once the thermal mass is returned to the surface.

An alternative embodiment of the invention can mitigate the energy expenditure required to raise warmed thermal masses from the thermal well. In this embodiment, at least two (2) paired thermal masses are connected by a single suspension cable, and serve as counter-weights for each other. Therefore, as one thermal mass is pulled down by gravity, it pulls its companion thermal mass up out of its thermal well.

Such counter-weight systems are commonly applied to the raising and lowering of construction materials for cranes, in the design of bridges, and the like. If the two thermal masses and cables are well matched, the only energy that need be lost to raise a thermal mass from a thermal well is the energy to overcome the friction of the cables against their mechanisms, and the air resistance as the thermal masses are raised and lowered. Proper lubrication can reduce the energy losses due to friction, while aerodynamic design of the thermal masses can help reduce the drag encountered when the thermal mass is raised and lowered in the well shaft.

The steps for this embodiment of the invention are illustrated in the flow diagrams of FIG. **14** and FIG. **15** and the overview cross-section diagram shown in FIG. **16**. Note that the illustrations shown here are not to scale. The wells are anticipated to be kilometers deep, while the thermal masses are expected to be, for example, 50 centimeters to 30 meters long and perhaps 10 centimeters to 1 meter in diameter.

To start, as shown in FIG. **13**, the initial step **3000** comprises digging well shafts **60** and **1060** into the Earth, until a portion of each well shaft **60** and **1060** is surrounded by a thermal pool **560**, forming respective first and second Heat Absorption Zones. In the next step **3050**, one end of the suspension cable **1140** is unwound, and in the third step **3100**, a thermal mass **100** is then prepared with a procedure that typically comprises attaching it to one end of the suspension cable **1140**, which in turn is attached to a control system **1148** for raising and lowering the thermal mass **100**.

Once the thermal mass **100** has been prepared, in the next step **3200** the thermal mass **100** is then lowered down the well shaft **60** until it reaches the first Heat Absorption Zone heated by the thermal pool **560**. After that, the next step **3300** comprises allowing the thermal mass **100** to remain surrounded in the first Heat Absorption Zone until a desired temperature is reached or a predetermined amount of heat has been transferred to the thermal mass **100**.

In the meantime, near the surface of the Earth **10**, a parallel step **3150** comprising unwinding the other end of the suspension cable **1140** occurs, and the second thermal mass **1100** is then prepared with a procedure step **3160** that typically comprises attaching it to the suspension cable **1140** which in turn is attached to the control system **1148** for raising and lowering the second thermal mass **1100**.

After this, the next step **3400** as shown in continuation flow chart of FIG. **15** comprises raising the heated thermal mass **100** to the first Heat Transfer Zone near the surface of the Earth **10** while simultaneously lowering the second thermal mass **1100** into the second Heat Absorption Zone of a second well shaft **1060**. By having the two thermal masses counterbalancing each other, the energy supplied by gravity to lower the second thermal mass **1100** pulls the first thermal mass **100** up the first well shaft **60**, and therefore the only energy that need be supplied to drive the process is the energy to overcome friction and aerodynamic resistance of the thermal masses **100** and **1100** in their respective well shafts **60** and **1060**.

17

The next step 3530 comprises allowing the thermal mass 1100 to remain in the second Heat Absorption Zone heated by the thermal pool 560 until a desired temperature is reached or a predetermined amount of heat has been absorbed by the thermal mass 100. In the meantime, in the first Heat Transfer Zone near the surface of the Earth 10, an alternative step 3500 executed in parallel comprises extracting the heat energy from the thermal mass 100 and transferring it to a thermal reservoir 200-2. Once the heat has been transferred from the thermal mass 100, the thermal mass 100 can be prepared according to the next alternative step 3550 for re-insertion into the well shaft 60.

After this, the next step 3600 comprises raising the heated second thermal mass 1100 to the second Heat Transfer Zone near the surface of the Earth 10 while at the same time lowering the first thermal mass 100 to the first Heat Absorption Zone of its well shaft 60. By having the two thermal masses counterbalancing each other, the energy supplied by gravity to pull the first thermal mass 100 down pulls the second thermal mass 1100 up the second well shaft 1060, and therefore the only energy that need be supplied to drive the process is the energy to overcome friction and aerodynamic resistance of the thermal masses 1100 and 100 in their respective well shafts 1060 and 60.

The next step 3730 comprises allowing the first thermal mass 100 to remain in the first Heat Absorption Zone heated by the thermal pool 560 until a desired temperature is reached or a predetermined amount of heat has been transferred to the thermal mass 100. In the meantime, in the second Heat Transfer Zone near the surface of the Earth 10, a parallel step 3700 comprises extracting the heat energy from the second thermal mass 1100 and transferring it to a thermal reservoir 200-2. Once the heat has been transferred from the thermal mass 100, the second thermal mass 1100 can be prepared again according to the next alternative step 3750 for re-insertion into the well shaft 60. Then, in a repetition of the previous step 3400, the heated thermal mass 100 is raised to the first Heat Transfer Zone while the second thermal mass 1100 is simultaneously lowered into the second Heat Absorption Zone of the second well shaft 1060, and with the subsequent repetition of the following steps 3500 through 3750, the cycle continues.

In the meantime, according to an alternative step 3800, the heat energy so transferred into the thermal reservoir 200-2 can be used for a number of useful processes, such as generating electricity, driving another industrial process such as pyrolysis, or simply being stored for later use in a production facility 250. A housing 1025 or other structure to protect the well shafts 60 and 1060 from the elements can also be constructed, either independent of, or in connection with the production facility 250.

FIG. 16 shows an overview schematic of a counterbalance system according to the invention. As before, a well shaft 60 has been drilled from the surface of the Earth 10 into the Earth so that a portion of the well shaft 60 is surrounded by a thermal pool 560, creating a Heat Absorption Zone. As before, the well shaft 60 can be lined with various casings, such as an insulating casing 62 in the upper portions of the shaft and a thermal casing 64 in the lower portion of the shaft. As before, a thermal mass 100, such as one described in the previous embodiments, is raised and lowered into the well shaft 60 on a suspension cable 1140. Heat can be transferred by one of the mechanisms described in the previous embodiments, such as complete detachment of the thermal mass 100, the transfer of a heated thermal fluid 55, or through the use of a thermal exchange fluid 35.

18

However, in this case, the suspension cable 1140 is also attached to a second thermal mass 1100 which is raised and lowered into a second well shaft 1060 that also has a portion of the well shaft 1060 surrounded by the thermal pool 560. This well shaft 1060 can also be lined with various casings, such as an insulating casing 62 in the upper portions of the shaft and a thermal casing 64 in the lower portion of the shaft. Typically, this second thermal mass 1100 would be of a matched type and design to the thermal mass 100, although variations may be desirable if some properties of the second well shaft 1060 differ from those of the initial thermal well shaft 60. A control system 1148 is used to control the mutual raising and lowering of the thermal masses in their respective well shafts 60 and 1060.

As in the previous embodiments, the thermal energy brought up with the initial thermal mass 100 or the second thermal mass 1100 can be used to generate electricity or drive another industrial process such as pyrolysis in a production facility 250. A housing 1025 or other structure to protect the well shafts 60 and 1060 from the elements can also be constructed, either independent of, or in connection with the production facility 250.

FIG. 17 shows a schematic of a counterbalance system according to the invention in more detail. Note that the illustration is not to scale, since the wells are anticipated to be kilometers deep while the thermal masses are expected to be 50 centimeters to 30 meters long.

In FIG. 17, as in the embodiment of FIG. 6, the thermal mass 100 has been raised to the surface and connected to the thermal reservoir 200-2 contained in a thermal reservoir containment 180 through the thermal transfer conduit 150 with a moving or telescoping junction 152 that connects using the thermal fluid connector 135. The suspension cable 1140 raises and lowers the thermal mass 100 and correspondingly lowers and raises the second thermal mass 1100, driven by a suspension mechanism 1141 that is controlled by a control system 1148.

As illustrated in FIG. 17, the second thermal mass will also require a means to unload its heat to the thermal reservoir 200-2, and in this illustration this is provided with a second thermal transfer conduit 1150 with a second telescoping junction 1152 that connects using the connector 1135 which is attached to the second thermal mass 1100 when it in turn has been raised near the surface of the Earth.

As in the previously described embodiments, it may be desired to have various sensors within the thermal masses. To facilitate the communication of data from these sensors on properties such as temperature, acceleration, distribution of mass, etc., a communication cable 942 driven by an independent mechanism 943 for the first thermal mass 100 and another communication cable 1142 driven by another independent mechanism 1143 for the second thermal mass 1100 may be used. These cables can be independently driven, or driven in concert by the control system 1148 that also controls the raising and lowering of the thermal masses 100 and 1100.

FIG. 18 illustrates a variation of this embodiment of the invention, in which a counterbalance system comprising two thermal masses is used, but only one well shaft 2060 need be drilled. As in the previous embodiments, the well shaft 2060 can be lined with various casings, such as an insulating casing 62 in the upper portions of the shaft and a thermal casing 64 in the lower portion of the shaft. As before, there is an initial thermal mass 100 and a second thermal mass 1100, both attached to alternate ends of a suspension cable 1140. One thermal mass is raised from the thermal pool 560 while the other is lowered into the thermal pool 560, and the

energy of gravity used to pull one weight down in turn is used to pull the other weight up. However, in this variation, a single well shaft **2060** has been dug, and the initial thermal mass **100** and the second thermal mass **1100** go up and down on different sides of a single well shaft **2060**. This can reduce costs, as only one shaft need be prepared, but may add complexity to the structures within the shaft.

If should be noted that, although we have described this embodiment as using one cable as the means of suspension, it will be known to those skilled in the art that ropes, chains, cords, wires, fibers, fabrics, nets, and other means of mutual suspension can be used to support the two counterbalanced thermal masses.

#### Additional Variations of the Invention

Although certain detailed embodiments have been described in this disclosure and illustrated in these drawings, it will be clear that some of the elements of other technologies, such as EGS, can also be combined with the embodiments described here. For example, the material for thermal casing **64** for the portion of the thermal well immersed in the thermal pool can be constructed from a material such as the grout used in the SWEGS prior art system.

Likewise, in some embodiments of the invention, more complex physical structures can be created in the Heat Absorption Zone, such as a network of drilled passageways to facilitate thermal migration. Also, a fluid, such as a glycol based fluid or a molten salt, can also be placed in the bottom of the thermal well, so that the thermal mass is completely or partially immersed in a bath of hot liquid when in the Heat Absorption Zone. The detailed designs of these structures created in the Heat Absorption Zone will, however, vary depending on the details of the geological strata and local thermal properties in the thermal well.

Although the descriptions presented here typically describe the use of a single thermal mass on a given suspension cable, another embodiment of the invention can have multiple thermal masses on a suspension system or track. Also, although the well shafts in this disclosure have typically been illustrated as vertical shafts into the ground, alternative, angled well shafts could also be employed, especially if a track were to be inserted into the well shaft to allow a "train" of thermal masses to be inserted into a Heat Absorption Zone. Such a thermal "train" may at first seem awkward because of its additional weight, but if an embodiment of the invention using a pair of "trains" arranged using two shafts in a counterbalance arrangement were employed, the energy acquired by one "train" as it was pulled into the Earth by gravity would balance the energy needed to pull the second "train" out of its respective well shaft, with the only significant losses due to friction of the "train" with its track and the friction of the moving cables, and the drag caused by the rush of the wind flowing past the thermal "train".

#### A Molten Salt Closed Loop Embodiment of the Invention

In the previously described embodiments, a thermal fluid such as molten salt is placed in cavity within a thermal mass. The heat is acquired in a Heat Absorption Zone, and then transferred to a thermal reservoir in the Heat Transfer Zone.

Variations of another embodiment of the invention using a thermal material such as molten salt without bundling the thermal material in a thermal mass are illustrated in FIG. **19** and FIG. **20**. In this embodiment, the thermal material does not need to be liquid at the beginning of the cycle, and can

in some embodiments be a solid, such as ground or powdered solid salt at room temperature. In a facility **5012** built at or near the surface of the Earth **10**, a circulating system **5018** directs this material into a first well shaft **5014**, which can comprise a driving apparatus such as a screw **5050**, as illustrated in FIG. **19**, or a pneumatic conveyor system installed in all or part of the well shaft **5014**, or, as illustrated in FIG. **20**, can simply be empty.

This driving apparatus can fill the well shaft **5014**, or be in several stages at various depths. In some embodiments of the invention may comprise an additional driver **5100** such as a ram screw that drives the thermal material into a chamber **5080** formed in the Heat Absorption Zone situated in the thermal pool **560**.

As the thermal material progresses into the Earth to the Heat Absorption Zone, it heats up and, if it is a material such as a solid salt mixture, it will melt and become a liquid at higher temperatures. This melted material **5055** fills or partially fills the thermal chamber **5080**, where it continues to absorb heat.

The pressure in the chamber **5080** created by the force on the thermal material provided by the additional driver **5100** pushes the hot material **5055** into the exit pipe **5040**, where it proceeds to rise again through the exit pipe **5040** in a second well shaft **5016** to the surface of the Earth **10** and from there into the Heat Transfer Zone in a production facility **5020**.

The exit pipe **5040** can surrounded by insulation **5062** for all or part of its length, and be designed as shown in the FIG. **19** and FIG. **20** with decreasing diameters for the cooler sections near the surface of the Earth **10**. With the same inflow of material at the base of the exit pipe **5040**, the thermal fluid in the sections of the exit pipe **5040** having a smaller diameter will have correspondingly higher velocity, and therefore have less time to cool as it rises to the Heat Transfer Zone.

Once in the Heat Transfer Zone, heat transfer from the thermal material proceeds as in the previously described embodiments. However, in this embodiment, the thermal materials can be cooled all the way down to room temperature, since the material does not need to be in liquid form for re-injection into the first well **5014**. If the thermal material is, for example, molten salt, the additional temperature change from its melting point ( $142^{\circ}\text{C}$ .) to room temperature ( $20^{\circ}\text{C}$ .) can, using the numbers from Table I, represent an additional transfer of 190 kJ of heat per kilogram of material.

As disclosed in the previous embodiments, the well heads and surface circulating system **5018** can be enclosed in a facility **5012** which can be connected to or otherwise integrated with the production facility **5020**.

With this application, several embodiments of the invention, including the best mode contemplated by the inventors, have been disclosed. It will be recognized that, while specific embodiments may be presented, elements discussed in detail only for some embodiments may also be applied to others.

It will also be recognized that, while generating electricity is a common end use for the heat produced by these embodiments in the Heat Transfer Zone, other industrial processes, such as electrolysis of water for the generation of hydrogen and oxygen; or such as pyrolysis of organic materials for the generation of "Syngas" or for waste processing; or the direct generation of mechanical energy using a steam turbine; or for the heating of objects for industrial smelting, baking, or curing processes, may all be driven by the geothermal heat harvested according to the invention. It



## 21

will also be recognized that the thermal mass can comprise additional chambers and constructions designed to facilitate some or all of the steps of these industrial processes while the thermal mass is still present into the Heat Absorption Zone. Other processes and end uses for the geothermal heat that may be known to those skilled in the art.

While specific materials, designs, configurations and fabrication steps have been set forth to describe this invention and the preferred embodiments, such descriptions are not intended to be limiting. Modifications and changes may be apparent to those skilled in the art, and it is intended that this invention be limited only by the scope of the appended claims.

What is claimed is:

1. A system for transferring geothermal heat, comprising:
  - a thermal mass;
  - a suspension cable, wherein the suspension cable is configured to be coupled to the thermal mass at a first end of the suspension cable and to a second thermal mass at a second end of the suspension cable;
  - a thermal fluid connector that is configured to couple to the thermal mass;
  - a telescoping junction that is configured to thermally couple the thermal mass to a thermal reservoir via the thermal fluid connector;
  - a second thermal fluid connector that is configured to couple to the second thermal mass;
  - a second telescoping junction that is configured to thermally couple the thermal mass to the thermal reservoir via the second thermal fluid connector;
  - a suspension mechanism that is configured to drive the suspension cable;
  - a control system that is configured to selectively raise and lower the thermal mass and the second thermal mass in alternating fashion via the suspension mechanism and the suspension cable;
  - a first communication cable that is configured to communicatively couple to one or more sensors disposed within the thermal mass, the first communication cable being configured to communicate sensor data gathered by the one or more sensors disposed within the thermal mass to the control system;
  - a second communication cable that is configured to communicatively couple to one or more sensors disposed within the second thermal mass, the second communication cable being configured to communicate sensor data gathered by the one or more sensors disposed within the second thermal mass to the control system.
2. The system as recited in claim 1, the thermal mass further comprising:
  - a thermal transfer tube thermally coupled to the thermal fluid connector;
  - a cover gas tube configured to engage a cover gas connector;
  - an internal data cable communicatively coupled to each of the one or more sensors disposed within the thermal mass.
3. The system as recited in claim 2, wherein the thermal mass further comprises:
  - a shoe coupled to the thermal transfer tube and configured to control flow of a thermal fluid into and/or out of the thermal transfer tube.
4. The system as recited in claim 3, wherein the thermal mass further comprises:
  - a plurality of spacers, each spacer of the plurality of spacers being configured to engage:

## 22

an exterior shell coupled to the thermal mass, and at least one of: the thermal transfer tube, the cover gas tube, the internal data cable, and the shoe.

5. The system as recited in claim 1, the thermal mass further comprising:
  - an exterior shell comprising:
    - a first terminal end having an aperture configured to engage the thermal fluid connector; and
    - a second terminal end configured to support material disposed within the exterior shell.
6. The system as recited in claim 5, the thermal mass further comprising:
  - a plurality of spacers arranged around a periphery of the exterior shell, each spacer of the plurality of spacers being configured to absorb impact forces resulting from collision between the thermal mass and an external object; and
  - a first flange coupled to the first terminal end of the exterior shell; and
  - a second flange coupled to the second terminal end of the exterior shell.
7. The system as recited in claim 6, each flange further comprising:
  - a plurality of apertures configured to engage the suspension cable; and
  - a sealing component configured to seal the exterior shell to the flange.
8. The system as recited in claim 7, further comprising a top flange configured to engage the first flange and the suspension cable via the plurality of apertures associated with the first flange.
9. The system as recited in claim 8, the top flange further comprising:
  - the thermal fluid connector;
  - an internal cover gas tube;
  - a cover gas connector; and
  - a data connector configured to communicatively couple to at least one of the first communication cable and the second communication cable.
10. The system as recited in claim 1, the thermal mass further comprising internal piping configured to facilitate heat exchange between the thermal mass and a thermal exchange fluid disposed in the internal piping.
11. The system as recited in claim 10, the internal piping being configured in a coiled arrangement.
12. The system as recited in claim 11, the coiled arrangement comprising a double helix.
13. The system as recited in claim 11, the coiled arrangement comprising a helical heat exchange portion and a linear return portion.
14. The system as recited in claim 1, the thermal mass further comprising a thermal exchange medium.
15. The system as recited in claim 14, the thermal exchange medium comprising a metal.
16. The system as recited in claim 14, the thermal exchange medium comprising a thermal exchange fluid.
17. The system as recited in claim 16, wherein the thermal exchange fluid comprises a material selected from a group consisting of:
  - a molten salt,
  - water,
  - a glycol-based fluid,
  - a metal, and
  - a gas.

## 23

18. The system as recited in claim 17, wherein the molten salt includes at least one of:

potassium nitrate,  
potassium calcium nitrate,  
sodium nitrite,  
sodium nitrate,  
sodium chloride,  
potassium fluoride,  
potassium chloride, or  
sodium fluoride.

19. The system as recited in claim 17, wherein the gas includes at least one of nitrogen, argon, helium, or compressed carbon dioxide.

20. The system as recited in claim 1, wherein the thermal mass and the second thermal mass are each characterized by an approximately equal mass.

21. The system as recited in claim 20, wherein the thermal mass and the second thermal mass are configured in a countermeasure arrangement via the suspension cable.

22. The system as recited in claim 1, further comprising a pumping system configured to fill the thermal mass with a thermal exchange fluid.

23. The system as recited in claim 1, further comprising a cover gas system configured to fill the thermal mass with a cover gas.

24. The system as recited in claim 23, the cover gas system comprising:

a valve configured to couple to a cover gas connector of the thermal mass;  
a cover gas manager, the cover gas manager including a cover gas pumping system, and a cover gas reservoir; and  
piping coupled to the cover gas manager and the valve.

25. The system as recited in claim 23, the cover gas comprising a material excluding air.

26. The system as recited in claim 1, wherein the thermal mass is configured to include one or more of a temperature sensor, motion sensors, an accelerometer, infrared sensors, acoustic sensors, optical sensors, fluorescence sensors, or pressure sensors as the one or more sensors of the thermal mass.

27. The system as recited in claim 26, the temperature sensor comprising one or more of a platinum resistance thermometer and a dual metal thermostat.

28. The system as recited in claim 1, further comprising:  
a pumping system configured to fill the thermal mass with a thermal exchange medium;

a cover gas system configured to fill the thermal mass with a cover gas excluding air, the cover gas system comprising:

a valve configured to couple to a cover gas connector of the thermal mass,  
a cover gas manager, the cover gas manager including a cover gas pumping system, and a cover gas reservoir; and

piping coupled to the cover gas manager and the valve, wherein the thermal exchange medium is either a metal or a thermal exchange fluid,

wherein the thermal exchange fluid includes at least one of a molten salt, water, a glycol-based fluid, and a gas,

wherein the molten salt includes at least one of potassium nitrate, potassium calcium nitrate, sodium nitrite, sodium nitrate, sodium chloride, potassium fluoride, potassium chloride, and sodium fluoride,

## 24

wherein the gas includes at least one of nitrogen, argon, helium, or compressed carbon dioxide;  
an internal data cable communicatively coupled to each of the one or more sensors in the thermal mass;

a shoe coupled to a thermal transfer tube and configured to control flow of the thermal exchange fluid into and/or out of the thermal transfer tube;

a plurality of interior spacers, each interior spacer being configured to engage:

an exterior shell coupled to the thermal mass, and  
at least one of: the thermal transfer tube, a cover gas tube, the internal data cable, and the shoe, the exterior shell comprising:

a first terminal end having an aperture configured to engage the thermal fluid connector, and  
a second terminal end configured to support material disposed within the exterior shell;

a plurality of exterior spacers are arranged around a periphery of the exterior shell, each exterior spacer being configured to absorb impact forces resulting from collision between the thermal mass and an external object;

a first flange coupled to the first terminal end of the exterior shell;

a second flange coupled to the second terminal end of the exterior shell, each flange of the first flange and the second flange further comprising:

a plurality of apertures configured to engage the suspension cable, and  
a seal configured to seal the exterior shell to the flange;

a top flange configured to engage the first flange and the suspension cable via the plurality of apertures associated with the first flange, the top flange further comprising:

the thermal fluid connector, and  
an internal cover gas tube;

a data connector configured to communicatively couple to at least one of the first communication cable and the second communication cable;

internal piping configured to facilitate heat exchange between the thermal mass and a thermal exchange fluid disposed in the internal piping, the internal piping arranged as one or more of:

a double helix, and  
a helical heat exchange portion and a linear return portion,

wherein the thermal mass and the second thermal mass are each characterized by an approximately equal mass,

wherein the thermal mass and the second thermal mass are configured in a countermeasure arrangement via the suspension cable, and

wherein the one or more sensors of the thermal mass comprise one or more of:

one or more temperature sensors comprising one or more of a platinum resistance thermometer and a dual metal thermostat,  
one or more motion sensors,

one or more accelerometers,  
one or more infrared sensors,  
one or more acoustic sensors,

one or more optical sensors,  
one or more fluorescence sensors, and  
one or more pressure sensors; and

a thermal transfer tube coupled to the thermal fluid connector, wherein the cover gas tube is configured to engage the cover gas connector.

**25**

**29.** A thermal mass, comprising:  
 an internal chamber at least partially filled with a thermal fluid and in which the remainder of the internal chamber is filled with a cover gas;  
 a thermal fluid connector to enable insertion of the thermal fluid into the thermal mass and/or removal of the thermal fluid from the thermal mass;  
 an exterior shell comprising:  
   a first terminal end having an aperture configured to engage the thermal fluid connector, and  
   a second terminal end configured to support material disposed within the exterior shell;  
 a plurality of shock absorbing spacers arranged around a periphery of the exterior shell, each shock absorbing spacer being configured to absorb impact forces resulting from collision between the thermal mass and an external object;  
 a first flange coupled to the first terminal end of the exterior shell; and  
 a second flange coupled to the second terminal end of the exterior shell.

**26**

**30.** The thermal mass of claim **29**, wherein the thermal fluid comprises water.

**31.** A thermal mass, comprising  
 a suspension cable, wherein the suspension cable is configured to be coupled to the thermal mass at one end of the suspension cable;  
 an internal channel to allow a thermal transfer fluid to flow through the thermal mass; and  
 a thermal fluid connector to enable insertion of the thermal transfer fluid into the thermal mass and/or removal of the thermal transfer fluid out of the thermal mass;  
 a temperature sensor comprising one or more of a platinum resistance thermometer and a dual metal thermostat;  
 a pressure sensor;  
 an accelerometer; and  
 one or more of an infrared sensor, an acoustic sensor, an optical sensor, and a fluorescence sensor.

\* \* \* \* \*