

SK45/60 SKID STEER LOADER
OPERATION MANUAL
SK45/60

CHECK LISTS:

Pre-Delivery

Pls check the following important checklist:

- Unit has not been damaged during shipment. Check for such things as dents and loose or missing parts, correct or replace components as required.
- Battery is securely mounted and not cracked. The connections of cables are tight and electrolyte is at proper level. (Batteries for domestic sales are filled with electrolyte in the factory)
- Lifting and tilt cylinder, hoses and fittings are not damaged. Leaking or loosely connected.
- Filters are not damaged, leaking or loosely secured.
- Radiator hoses and fittings are not damaged, leaking or loosely secured.
- Wheels are properly and securely attached and tyre are properly inflated.
- Loader is properly lubricated and no grease fittings are missing or damaged.
- Hydraulic system reservoir, engine crankcase and drive chain-cases are filled to their proper levels
- All guards, shields and decals are in place and securely attached.

Start loader engine and run the unit while checking the proper operation is exhibited by all controls:

- Driven chains are properly adjusted.
- Steering control lever can be operated properly and are not damaged or bound.
- Steering control lever properly is adjusted for a correct "neutral" position so that loader does not creep.

INDEX

Forward	1
Serial Number Form	2
Specification	3
Identification of Parts	6
Options and Accessories	7
Safety Instructions	9
Machine Signs (Decals)	11
Operation Instructions	12
For New Loader	12
Preparation Before Start	12
Daily Inspection	12
Instrument Panel	13
Steering Lever	14
How to Operate	16
Operation Procedure	20
Preventive Maintenance	
Safety Maintenance	33
Maintenance Schedule	36
Lifting Arm Support Device	37
Engaging Lifting Arm Support Device	37
Disengaging Lifting Arm Support Device	37
Operating Cab	38
Safety Bar	40
Safety Belt	41
Air Filter	41
Engine Lubrication System	44
Engine Cooling System	46
Fan Belt	48
Hydraulic Oil	48
Check the Oil of Chain	48
Change Oil	48
Electronic System	53
Battery	53
Muffler	55
Tyre	56
Trouble Shooting	58
Electronic System	59
Hydraulic System	59
Safety Operation Manual	60

FOREWORD

Congratulations for you having this skid steer loader !

This manual contains a number of instructions and safety recommendations for operation, lubrication, maintenance and adjustment of the loader.

The manual is to promote safety maintenance and enhance machine performance efficiency.

Continuing improvement in the design of this machine can lead to changes in detail which may not be reflected in this manual. Consult our company for the latest available information for your machine or for

Our company or our distributor is happy to help you.

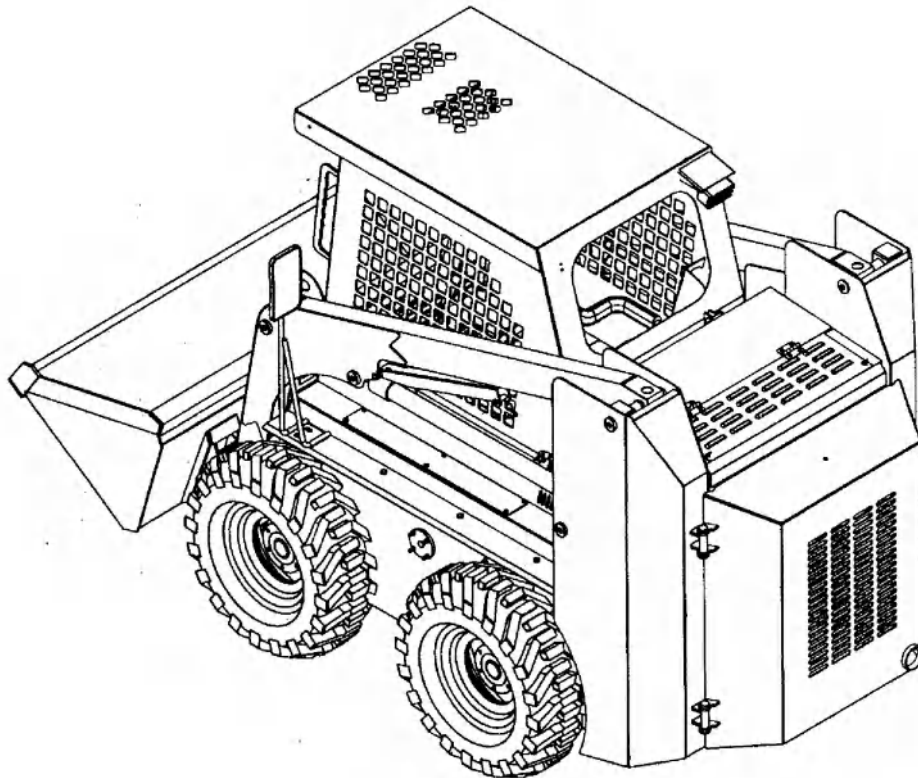

SERIAL NUMBER:

Always use the serial number of the loader when requesting service information or when ordering parts. Early or later model (identification made by serial number) may use different parts. And it may be necessary to use a different procedure in doing a specific service operation.

1) Loader Serial Number

The loader serial number is on the nameplate which is located on the outside of the hydraulic oil tank. Fig[A]

2) Engine Serial Number

The engine serial number is on the engine injection pump. The serial number is in the location shown. Fig [B]



Fig[A]

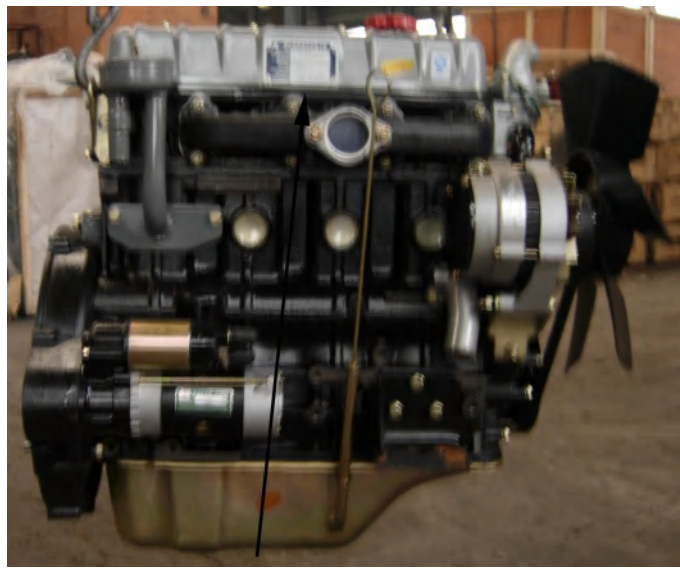
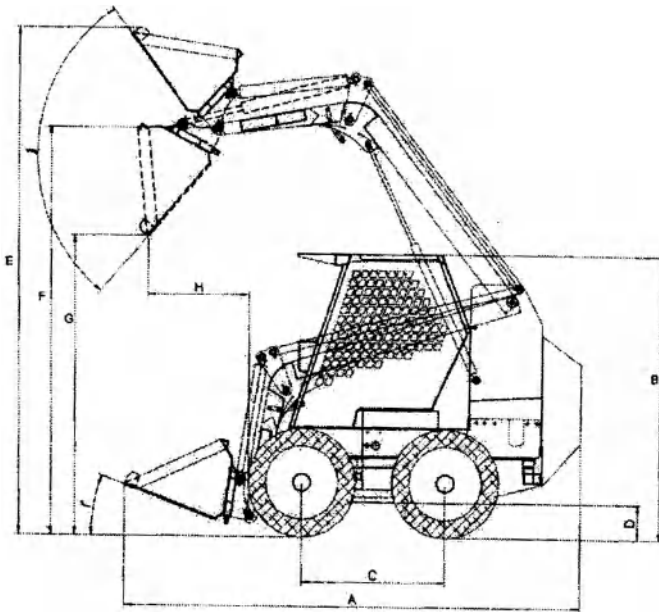

Fig [B]

SPECIFICATION (ZJ45/ZJ60)



Loader (side view) (mm)

Contents	ZJ45	ZJ60
Overall length (A)	3390	3490
Overall width	1680	1820
Overall height (B)	1995	2025
Wheel base (C)	991	991
Ground clearance (D)	180	200
Overall operating height (E)	3670	3700
Height to hinge pin (F)	2900	2930
Dumping height (G)	2290	22320
Dumping reach (H)	710	710

Forward tilt angle (I)	30°	30°
Backward tilt angle (J)	88	88

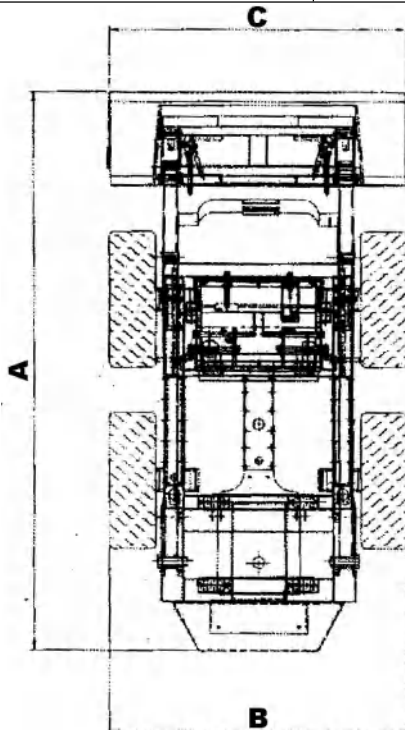

Loader (plane view) (mm)

contents	ZJ45	ZJ60
Overall length (A)	3390	3490
Overall width (B)	1680	1820
Bucket width (C)	1680	1820

- Dimensions are given for loader equipped with standard tires and bucket. It may be different with other bucket types, All dimensions are shown in millimeters.
- Specifications subject to change without notice.

MAIN SPECIFICATION

ITEM	ZJ45	ZJ60
Max. Loading Weight (kg)	750	850
Bucket Capacity (m ³)	0.36~0.4	0.4~0.5
Max. Travel Speed(km/h)	0~10.3	0~10.3
Fuel/Hyd.Oil Capacity(L)	45	45
Weight (kg)	2290	2800

SPECIFICATION (Cont'd) (Major components)

1) Engine

Item	Type	
Engine model	Xinchai C490BPG-2A	Perkins (804c-33)
Type	Water cooled,4 cylinder diesel engine, valve on top	Water cooled,4 cylinder diesel engine, valve on top
No of cylinder	4 in line	4 in line
Fire order	1-3-4-2	1-3-4-2
Rated power	37KW	56KW
Turning direction	Counter-clock wise as viewed from flywheel	Counter-clock wise as viewed from flywheel
Fuel	Diesel	Diesel
Governor	Full speed governor	Full speed governor
Fuel injector	Hole type	Hole type
Lubrication system	Gear pump pressure lubrication type	Gear pump pressure lubrication type
Engine oil	CC or better	CC or better
Cooling system	Circulation forced water cooled	Circulation forced water cooled
Starting motor	Type: QD 1315X 2.5kw	12V
Generator	Type: JF 11A 14v 350w	24V-55A

2) Main pump

Item	Type	
	ZJ45	ZJ60
Type	Axial piston pump	Axial piston pump
Displacement	50cc/rpm	50cc/rpm
Maximum operation pressure	250bar	250bar
Rated speed	99.1L/2400rpm	99.1L/2400rpm

IDENTIFICATION OF PARTS

Front

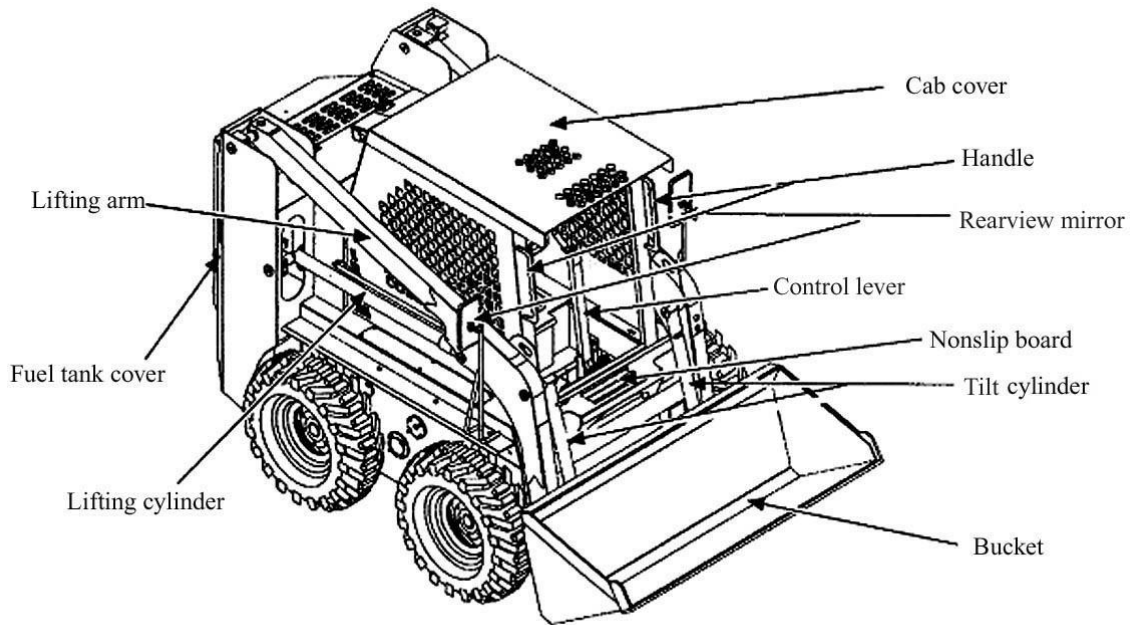

Rear

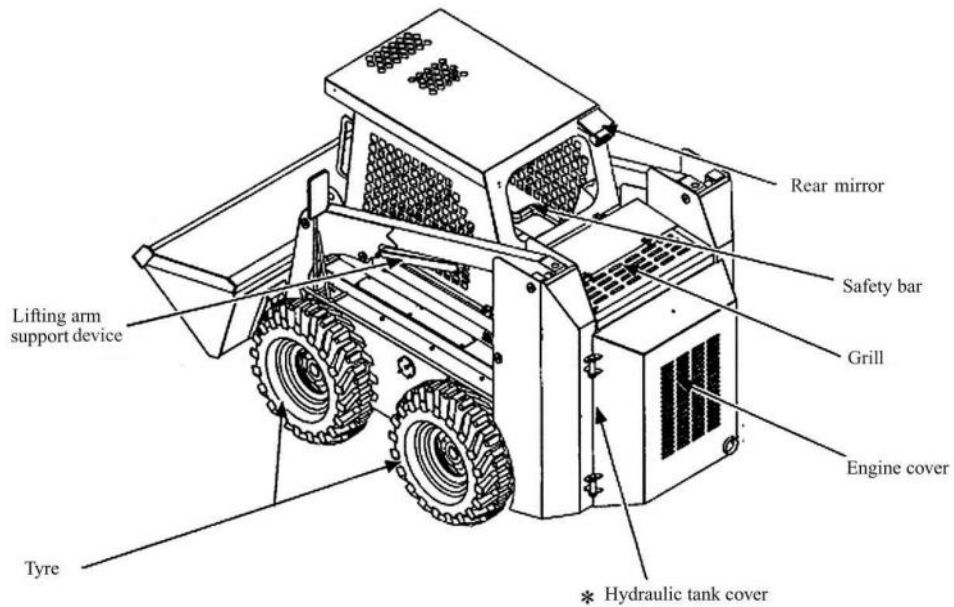

*mark- located inside the frame

OPTIONS AND ACCESSORIES

All loaders are standard equipped, with the following items:

Quick coupler	Operating cab
Safety bar	Lifting arm support device

Below is a list of the equipment which varies by model:

Tyres	
Tyres	Std
Operating Cab	
Black cushion seat	Std
Front/rear light	Std
Top window	Std
Rear window	Std
Front window	Std
Horn	Opt
Safety belt	Opt
Air condition	Opt
Instrument panel	
Gauge and lights	Std
Auto leveling system	Std
Hydraulics	
Auto leveling system	Opt
Auxiliary hydraulics	Opt
Quick coupler	Std

Std = Standard Equipment

Opt =Option

Specifications subject to change without notice.

SAFETY INSTRUCTIONS

	<h1>WARNING</h1>
<p>Instructions must be followed before operating or servicing machine. Read operation & maintenance manual and signs (decals) on machine. Follow warning and instruction in the manuals when making repairs, adjustment or servicing. Check for correct function after adjustment, repairs or service. Failure to follow instructions can cause injury or death</p>	

SAFETY IS THE OPERATOR'S RESPONSIBILITY

Most accidents happen because operators do not observe safety instructions. Accidents can be avoided if you are careful enough to recognize dangerous situations before they happen. Please have enough knowledge of safety instructions before you carry out maintenance, operation and fuel supply for skid steer loader. Basic precautionary measures and operation in a dangerous place are shown on safety instructions.



THIS SIGNAL MEANS WATCHFULNESS. PRECAUTION FOR YOUR SAFETY.

	<h2>WARNING</h2>
<p>Operator should understand all the instructions as follows.</p>	



It is reasonable for you to understand each instruction about operation and maintenance of equipment and follow related rules.

	<h2>WARNING</h2>
<p>All warnings on the loader are for your safety</p>	

* Improper fuel supply sometimes can cause dangerous and fatal situations when operating the loader



- You are prohibited from operating and maintaining the loader and filling in diesel or lubricant before you have full knowledge of this operator's manual
-  This sign is to let you know that you must watch out otherwise it can cause fatal dangerous to operator and bystanders. It is attached on loader to let you notice dangerous situations. All warnings are marked on the sign located on the boards of loader and the operation manual. We hope you are aware of all involved dangerous matters fully and try to prevent from accident.

SAFETY INSTRUCTIONS (cont'd)

Each equipment is tested and inspected carefully before delivering the loader to customers.

To operate each part well, you need to operate the loader carefully for about 100hours since you purchased it. If you handle it roughly in an abnormal way, the life span would be reduced and efficiency might be fallen too. For new equipment, pls especially pay attention to the matters below

- Please warm up the engine properly for 5 minutes after starting the engine.
- Please avoid operating the loader at full speed.
- Please avoid quick start, acceleration, unnecessary quick stop and rotation.
- When you replace the oil filter element, please wash out dust and debris on it.
- If operation conditions get worse, please inspect possible causes before operating the loader.
- Please check the operating time on the hour meter.

 DANGER,  WARNING,  IMPORTANT, these signs are closely related to safety of the operator and loader.

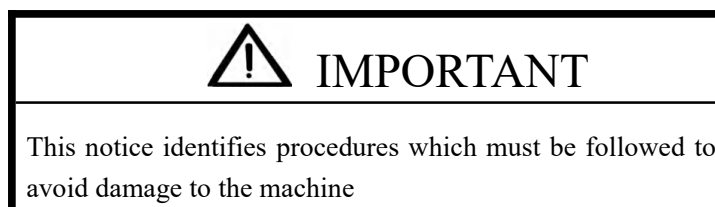
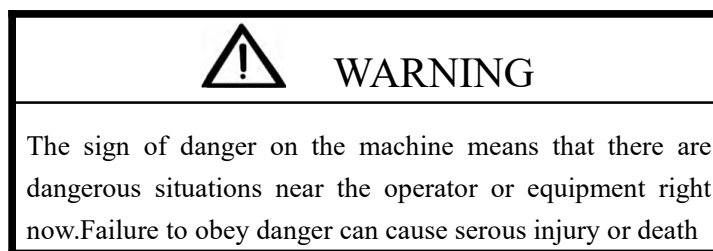
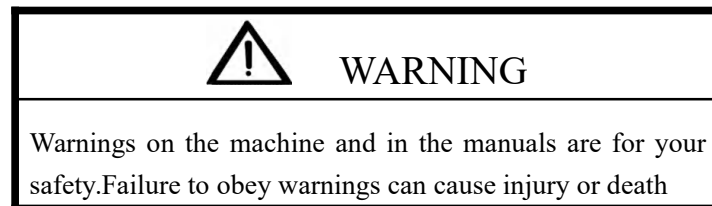

MACHINE SIGNS (DECALS)

Follow the instructions of all the machine signs (Decals) that are on the loader. Replace any damaged machine signs and be sure they are in the correct locations.

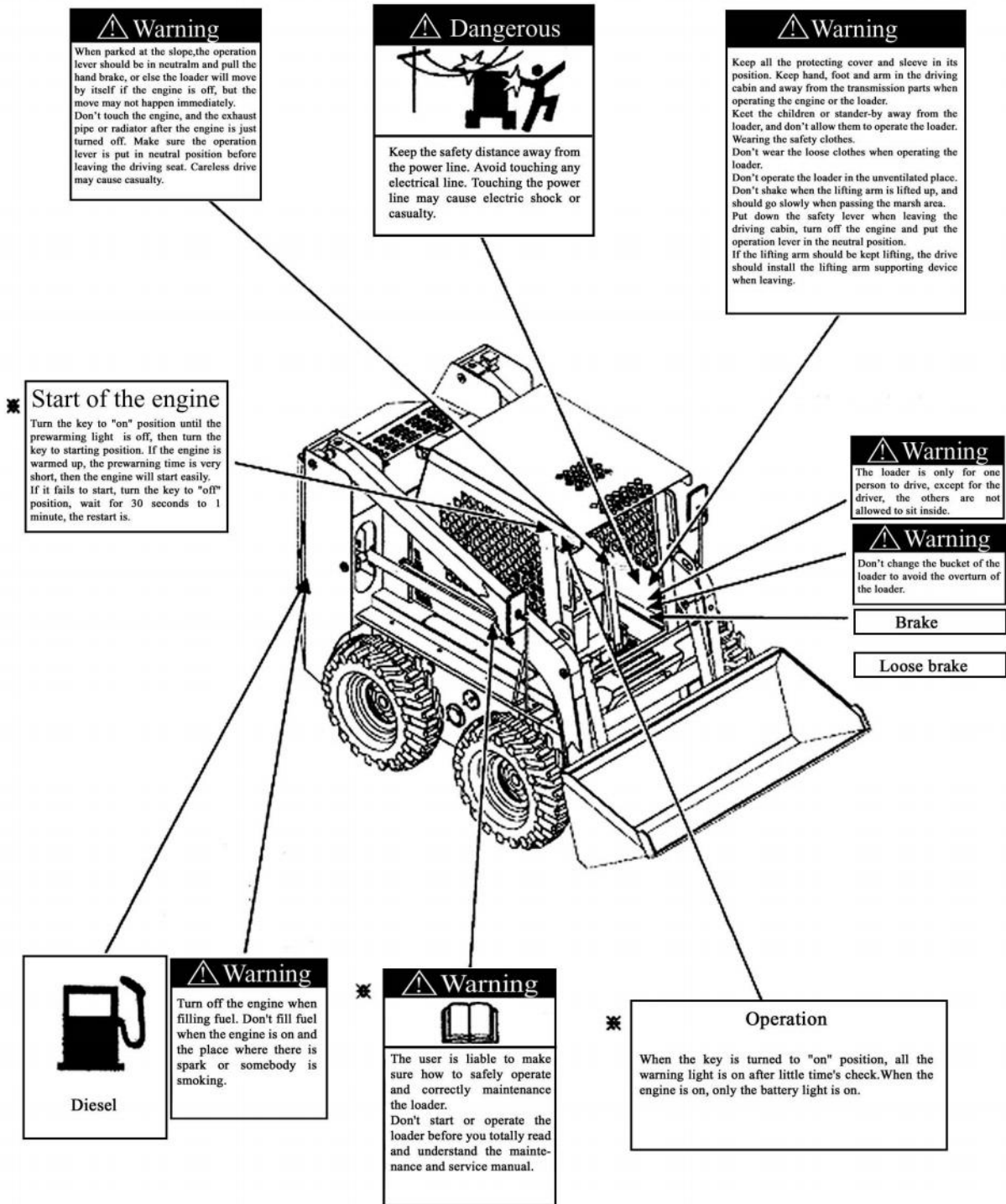

OPERATING INSTRUCTIONS

FOR NEW LOADER

It takes about 100 operating hours to enhance its designed performance. Operate according to below three steps and avoid excessive operation for the initial 100 hours.

hour	load
until 10 hours	about 60%
until 100 hours	about 80%
after 100 hours	100%

Be careful during the initial 100 operating hours.

PREPARATION FOR START

Read the operation and maintenance manual before operating the loader.

Use the bucket or attachment steps, grab handles and safety treads to get on and off the loader. Safety treads are installed on the loader to provide a slip resistant surface for getting on and off the loader. Keep safety treads clean and replace when damaged. Pull the seat bar and adjust the seat position for comfortable operation of the loader. Lower the safety bar. All controls must be in the neutral position before you start the engine.

DAILY INSPECTION:

The loader must be in good operating condition, check daily for the follow items:

- Engine cooling system
- Operator cap, safety bar, lift arms
- Tyres and tyre pressure.
- Any loose or broken parts
- Safety signs
- Instrument panel

Check for the level and leakage of coolant, engine oil, hydraulic oil and fuel.

- Check regularly the lubrication and fill.
- Check the gauges and lights during operation.
- Check if the machine is operating normally during operation.
- Grease daily all lubrication points.
- Tighten bolts



Excessive operation may deteriorate the potential performance of machine and shorten lifetime of the machine.



WARNING

Operator must read the instructions before operating the loader. Untrained operators may get injury and death.



WARNING

Avoid injury or death when operating the loader: The safety bar must be lowered. The safety belt must be fastened well. Keep your feet on the pedal.

INSTRUMENT PANEL

Gauges and Switches

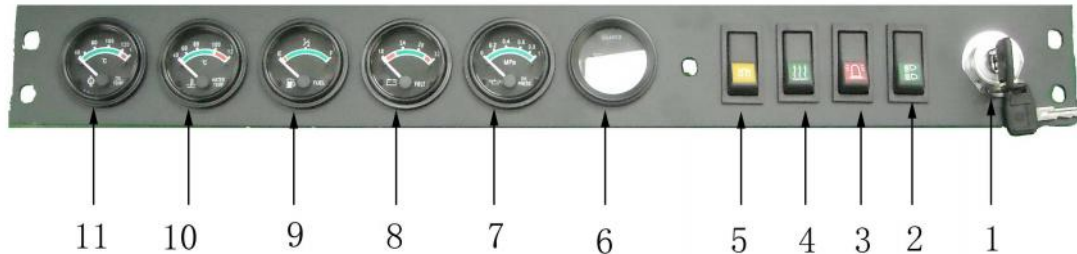

1、 Ignition Swich



OFF: This is the normal position with the engine off. Remove the key when the machine is not use.

ON: This is the normal running position.

START: This will start the engine.

NOTE:Steering control lever must be in neutral to start the engine

2、 Light switch

3、 Warning Light

4、 Heater switch

5、 Warm-up switch

6、 Hour Meter

This is used to keep a record of the operating hours. This hour meter operates whenever the switch is on. The number inside the white circle indicates minute and the front number is hour.

7、 Engine Oil press gauge (The common value is greater than 0.3)

8、 Charging gauge

The common value is greater than 12v then the engine is working。 If the value is less than 12v, there is a problem with the electrical charging system during the engine rotation.

9、 Fuel Gauge

F-Indicate FULL

E-Indicate EMPTY

Fuel gauge indicates the amount of remaining fuel.In case you want to keep the loader for a long time, you have to fill the tank with fuel.: Confirm the amount of fuel before operating, Fill up fuel if there is not enough fuel because the lack of fuel can cause the loader to be stopped.

10、 Engine Oil Temperature Gauge

The oil temperature of Engine radiator is lower than 85℃ commonly; When the temperature is higher than 85℃, please check.

11、 Water Temperature Gauge

The water temperature of Engine radiator is lower than 95℃ commonly; When the temperature is higher than 95℃, please check.

STEERING LEVER

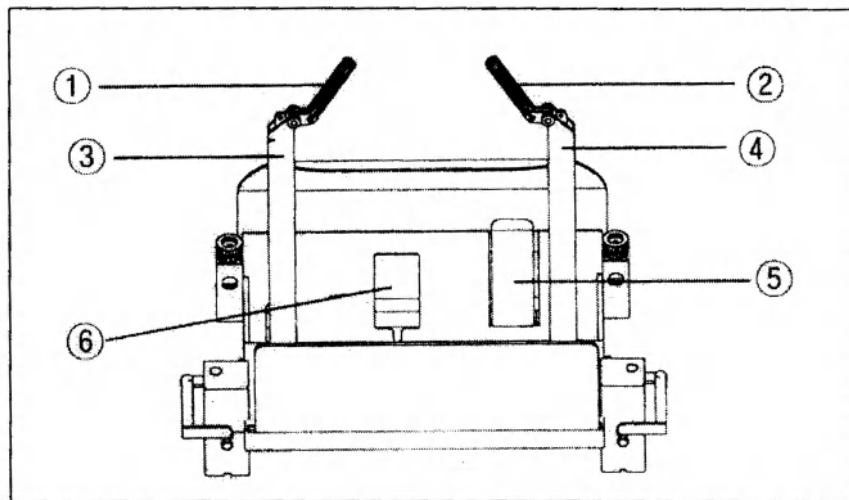

1. Bucket Operation Lever 2 Lift Arm Operation Lever 3 Steering Lever(L)
 4 Steering Lever ® 5 Accelerator 6 Aux.Hydraulic pedal (To operate attachment)

Handle Of Steering lever

Bucket operation lever

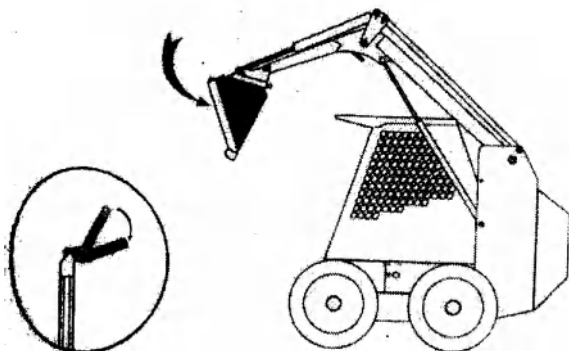
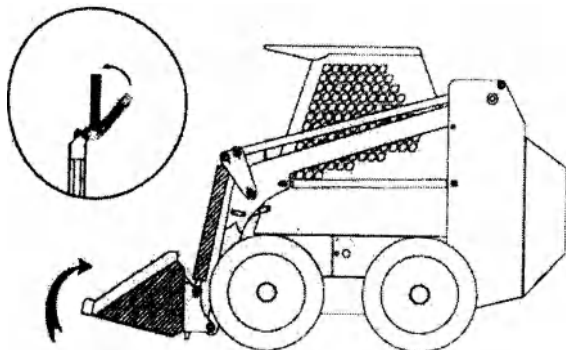

- Pull up the left lever to tilt the bucket forward
- You can dump a deposit out of the bucket.



WARNING

The operating speed of the bucket or lift arm is controlled by the power which is given to its operation lever.

- - P
- Push down the left lever to tilt the bucket backward
 You can put a deposit in the bucket.



WARNING

When you load and unload the stuff, operate the hydraulic control lever tenderly because sudden operation can cause the loader to incline So, operate it carefully.

LIFT ARM OPERATION LEVER

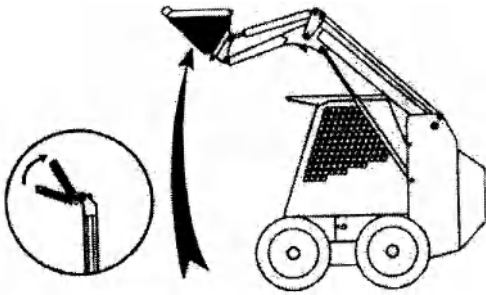

- Push down the right lever to raise the lift arms.
- It is used to load the contents of the bucket on a truck or other vehicles.

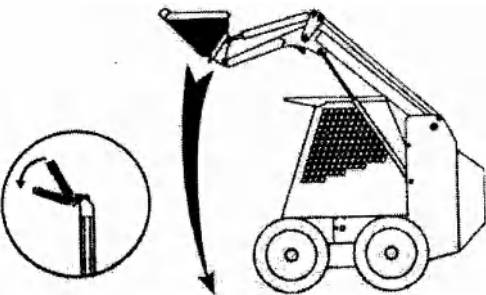

- Pull up the lever to lower the lift arms.
- It is used when you put the loaded stuff down and dump.

 WARNING
<p>The operating speed of the bucket or lift arm is controlled by the power which is given to its operation lever.</p>

*Self leveling system

When the lift arms rise and descend. The keeping the lever automatically. So it dropping cargo and reduces an equipment's

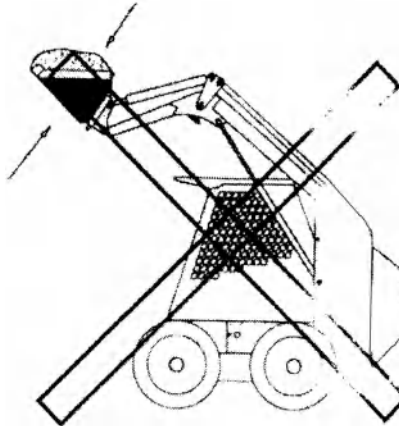

bucket also goes up and down prevents operator from shake.

 DANGER
<p>Do not travel or rotate when the lift arms raised. It can cause serious injury or death by overturning the equipment or dropping the loader stuff.</p>

 WARNING
<p>Never dump over an obstruction that can enter the operator cab. The machine could tip backward and cause injury and death.</p>

HOW TO OPERATE

HOW TO TRAVEL

- Lower the lift arms fully and the bucket only high enough to avoid obstructions when traveling.



DANGER

If you start or turn the loader rapidly with the lift arms raised. It can be overturned caused serious injury or death. Handle it carefully and slowly.

⓪ STOP

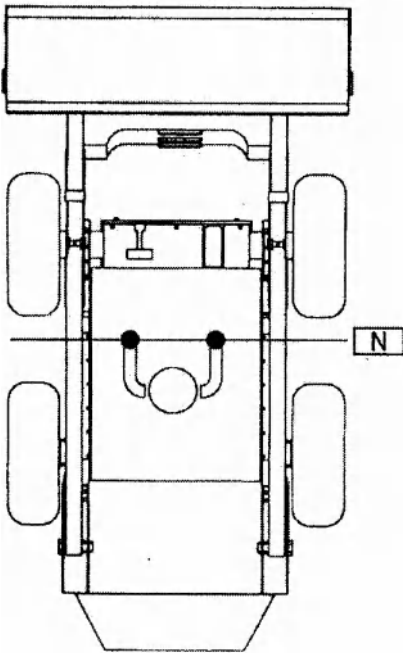

WARNING

When the loader travelling, Lower the parking brake and operate steering levers smoothly. It's dangerous to operate levers suddenly. If you move the loader with no lowering parking brake, smell and smoke happen by overheating the brake of the discs plate, then it cause trouble.



WARNING

When park the loader, stop the engine and then raise the parking brake.



WARNING

When you operate the steering levers, Avoid the abrupt movement and mover them slowly.

② TRAVELLING FORWARD

Move both steering levers forward at the same distance, then the loader will travel forward.

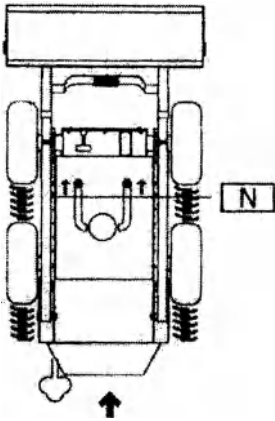

WARNING

Push steering levers to the end while traveling. If you do not move both levers forward and backward fully to the end while traveling the loader, smell and smoke happen by overheating the brake or the disc plate, then it cause a trouble.

③ TRAVELLING BACKWARD

Move both steering levers backward at the same distance, then you can drive the loader in reverse.

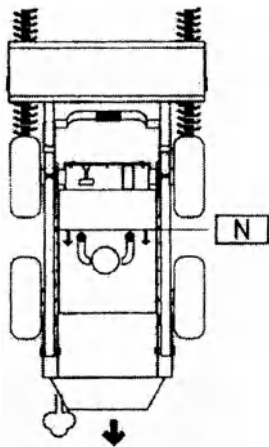

WARNING

Confirm if there are obstructions behind while traveling in reverse

④ STRAIGHT TURN TO THE LEFT

Put the left steering lever in neutral position and push the right steering lever, then the loader will turn to the left. Put the left lever in neutral position while traveling forward, then the loader will turn to the same direction.

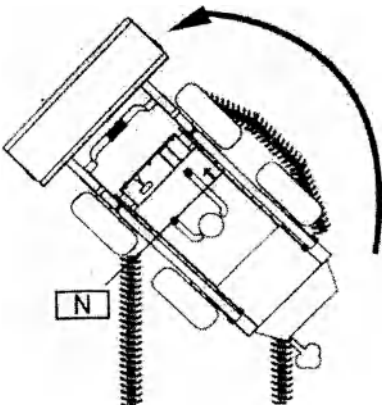

WARNING

If the loader turns with the lift arms raised, it can be overturned causing serious injury or death



WARNING

If the loader turns with the lift arms raised, it can be overturned causing serious injury or death

⑤ STRAIGHT TURN TO THE RIGHT

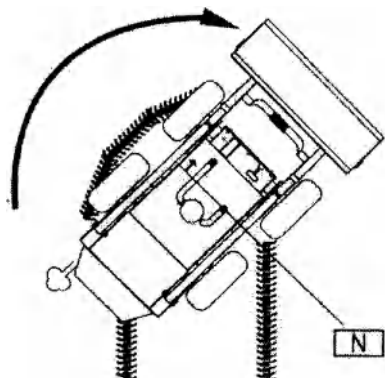

Put the right steering lever in neutral position and the left lever, then the loader will turn to the right.

If you put the steering lever in neutral position even while traveling forward, the loader will turn to the right

⑥ OPPOSITE TURN TO THE LEFT

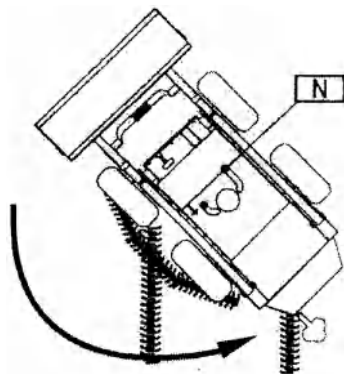

Put the right steering lever in neutral position and pull the left lever backward, then the loader will turn to the left.

If you put the right steering lever in neutral position even while traveling backward, the loader will turn to the left.

⑦ OPPOSITE TURN TO THE RIGHT

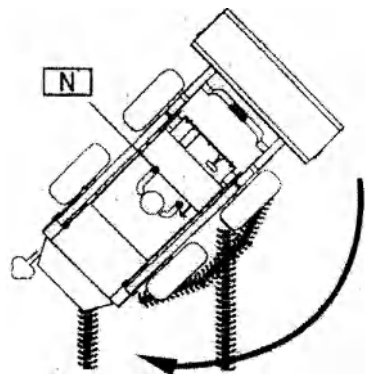

Put the left steering lever in neutral position and pull the right lever backward, then the loader will turn to the right oppositely.

If you put the left steering lever in neutral position even while traveling backward, the loader will turn to the right oppositely.

How To Operation(cont'd)

- ⑧ Turn left in the same place

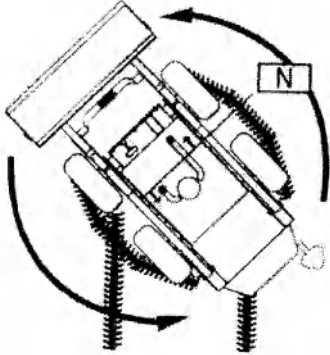

Pull left operation bar to the end,push right operation bar to the end,the loader will turn by 360°



WARNING

If turn and stop suddenly in case of lifting arm in up,the loader will roll over and maybe cause to death.

- ⑨ Turn right in the same place

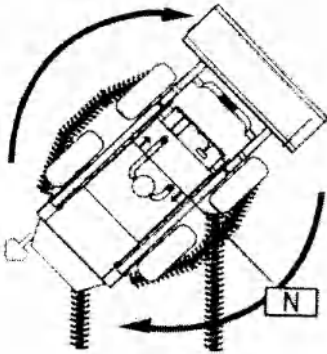

Push forward left operation bar,push backward right operation bar,the loader will turn by 180°



WARNING

If run and turn suddenly in case that lifting arm is in up and there are full of the goods in the bucket,the loader will roll over.

- ⑩ Run in slope

If possible,it's better to run and working in slope.Be careful when working in slope.



WARNING

The safety will be down when running in slope.So be careful when runing in slope. You should consider the movation of the centre and the loader when going up in the slope.pls reverse when going up in the slope.

}

Operation Procedure

Starting engine

Starting in normal circumstance

Adjust the position of seat in order to comfortable operation, put down safety bar. Adjust handle for the position of supplying oil, operate control bar and keep it in primitive position. Turn the key switch to "on" position, the warning light will bright after turning on.

Note: If the warning light will not be turned off after starting the engine, please stop the engine at once.

Turn the key to the position of starting, loosen it after starting the engine, the key switch will revert to the position of running.

The engine should run 5 minutes.

Starting the engine with low temperature

Comply with the procedure of starting in normal circumstance. If the temperature is under 0°, comply with the following in order to start the engine easily:

---change the oil so that the model and viscosity are suitable the starting temperature.

---Make sure the battery full.

Note: If fail to start, it must turn on again after waiting for 3 minutes at least if the switch had been turn off.



WARNING

When the engine is working in the sealed environment, fresh air must be taken in to avoid the high thickness of fume. The exhaust fume contain poison gas which is colourless. It can lead to the death unconsciously.



WARNING

Don't use the starting motor more than 15 seconds one time. Long time using of starting motor will make the starting motor over heat and lead to break. Cooling time should be at least one minute between two starting.



WARNING

Using the medium speed of the engine and light load to warm the machine can prolong the life of the loader.

Jumping starting

Jumping starting or battery replacement is required when the battery is discharged to a point where the battery will not turn the starter.

Follow the following procedure:

To jump start, be sure the battery fluid levels are correct and vent caps are tight. Place a damp cloth over the battery vent caps.

The booster battery must be a 12v type. The vehicle used for jump starting must have a negatively grounded electrical system.

Connect the “+” jumper cable to the “+” post of the discharge battery. Connect the other end the same jumper cable to the “+” terminal of the booster battery. Connect one end of the second jumper cable to the “—” post of the booster battery.

Make the final jumper cable connection to the engine block or the furthest ground point away from the battery.

Follow the steps in “normal starting”.

Remove jumper cables in the reverse order of their connection.



WARNING

To avoid personal injury when jump start the loader with another vehicle, be sure the vehicles are not touching. Keep sparks, flames and lit cigarettes away from the battery. Lead acid batteries generate explosive gases when charging or when the engine is running. Wear safety glasses when working near batteries.

Stop Of The Loader

Stop the loader at the leveling place .

Attention: Avoid stopping the loader on the slope. If needed, the shovel must be on the ground and the handle brake should be used, meanwhile, block the wheel. See picture A.

Set the gear lever and control handle at the center position.

Lower the arm completely, and make the edge of the shovel touch the ground.

Run the engine for 5 mins with idle speed.

Set the throttle at the position of idle speed.

Set the engine-off handle at the “off” position.

Turn the key to the “off” position and take out.

After turn off the engine, set the engine-off handle at the “on” position.

Accelerograph

ZJ loader has two kinds accelerograph equipment.

ZJ loader use accelerograph to adjust the rate of the engine.

A: Hand accelerograph

B: Foot accelerograph

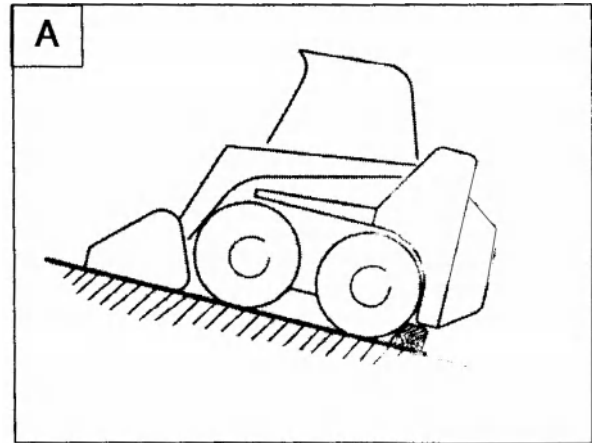

Storage of the loader

Storage after finishing of the work

Follow the following procedure after finishing of the work in order to next work:

Get rid of water and mud on body.

Park the loader on concrete or hard floor,if not possible,park on wood floor.

Let saving water in fuel system out.

The battery will be reduced in lower temperature ,so at night it should be covered or taken off to bring warm environment.

Long period storage

Used the following steps if long period stroage is wanted:

Clean all parts carefully.

Lubricate all parts which need to be lubricated exhaustively and change oil.

Wipe filmy grease on uncovered portion of cylinder piston rod

Let cooling water in radiator and cylinder block of diesel engine out.

Take off the battery which is full of electricity then place it in low temperature and dry area.

The loader should be stored indoor.If it must be stored outside,it should install the wheel locking device and cover the water-proof canvas



WARNING

During long period storage

Starting the engine

Drive the loader forward and backward.

Operate every pedal.

Process above mentioned procedure to lubricate all parts one time at least every month.



WARNING

After long period storage

Take off the fuel tank ,drainage plug of the oil tank,let all water out.

Start engine and warm for a certain time and check all parts carefully.

Driving

Before working, warm the machine.

The fresh operator should practise operating at the place where no others are available until skill can be suitable to all kinds of working environment.

Raise the bucket to such height which is just to avoid the uneven surface of the road.

It is dangerous to work on the slope place, avoid working on the slope which exceed 10 degree.

While the bucket is full, go up or down the slope with the heavy end toward the top of the slope

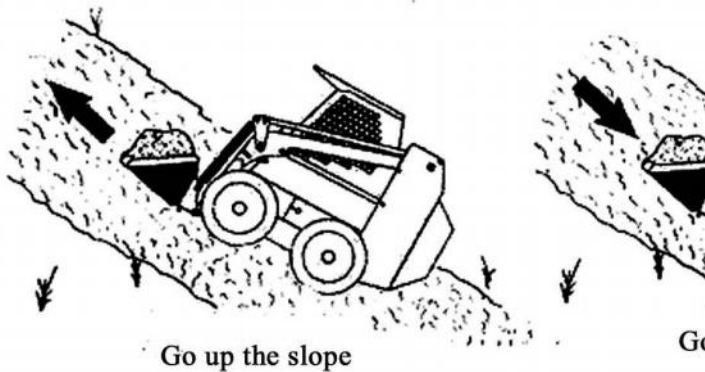

	WARNING
Don't work on the slope place and try to work at leveling ground because the centre move much while working in the slope.	

While the bucket is empty, go up or down the slope with the heavy end toward the top of the slope

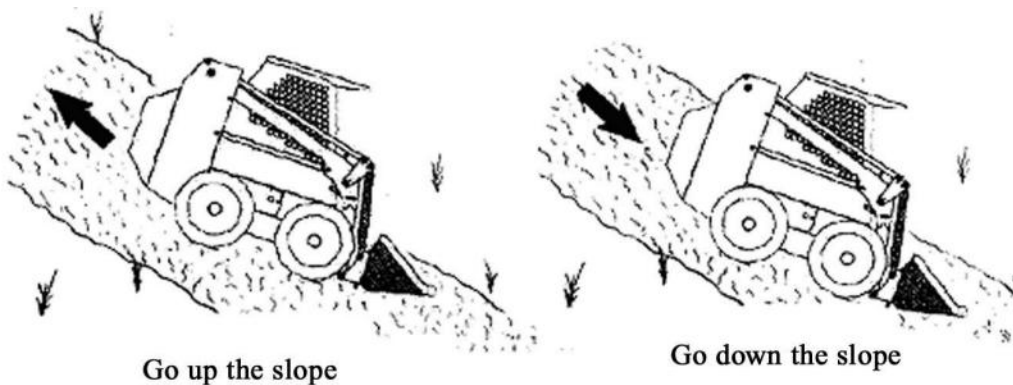

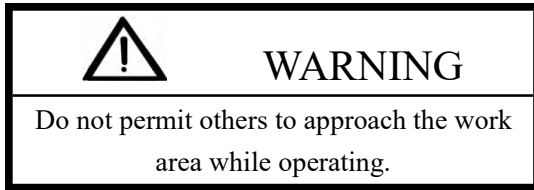

remove loose material stuck in the bottom of the bucket. It could reduce the loader's life owing to damage on the cylinder.

-

Filling the bucket

Drive slowly the material with the lift arms are all the way down and put the cutting edge of the bucket on the ground.

Push forward the steering control lever. Put the material in the bucket and raise the front of the bucket after filling the bucket with the material, operate the levers which control the lift arms and the bucket to make the bucket full of the material.

Move backward away from the material.

NOTE:

- Flatten the bottom of the bucket on the ground and not to exceed rated operating capacity.
Never do work which exceeds rated operating capacity of the loader.

EMPTY THE BUCKET

Raise the bucket over the cab.

Drive forward slowly until the bucket is on the top of the cab.

Empty the bucket with the bucket tilted forward after raising the lift arms enough.

Take attention not to collide the loader-body or the bucket with obstruction while loading and unloading and be careful not to drop the contents out of the bucket.

NOTE:

Do not fultter the bucket back and forth excessively to

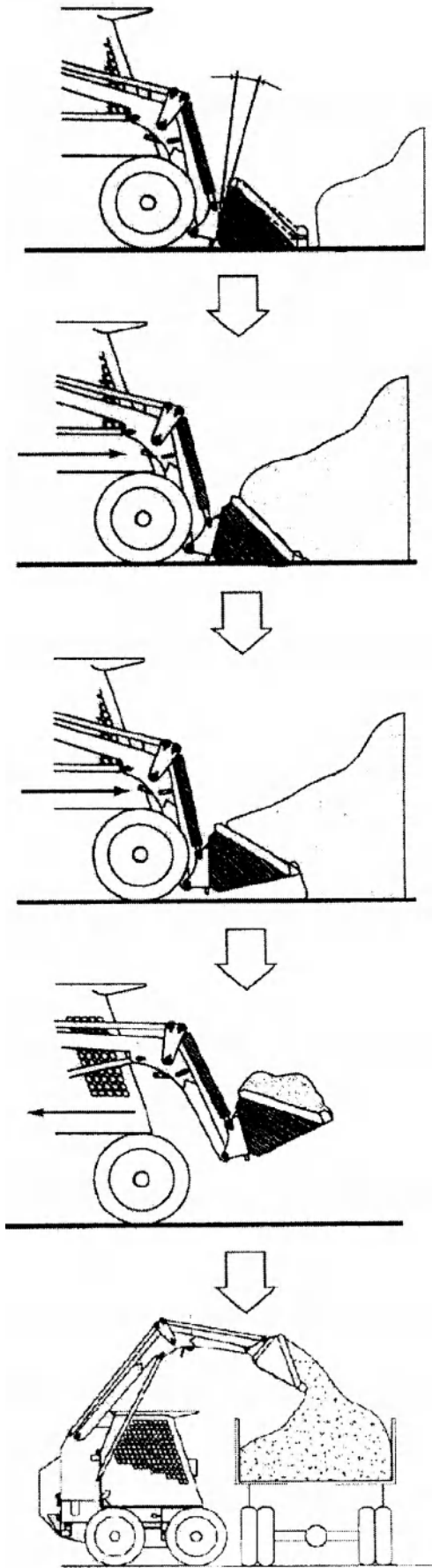

Digging in the ground

Put the lift arms down completely and put the cutting edge of the bucket on the ground.

Drive forward slowly and continue to tilt the bucket down until it enters the ground.

Bucket keep digging angle of 10-15 degree from the ground.

Fill the material in the bucket ,drive forward slowly and raise the lift arms with the bucket tilted backward.

Note:do not make an excessive angle between the bucket and the ground.

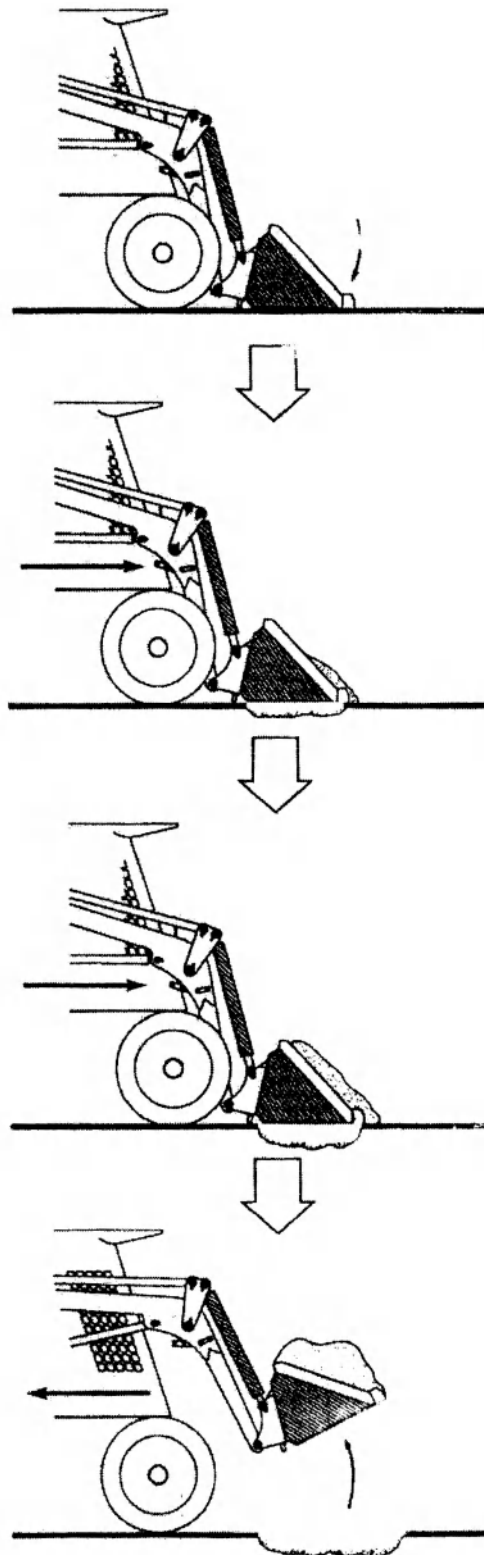

Fall the bucket and keep a distance with the ground. Drive forward to lay open the material, then drive back and forward to lever up the material.

The more the bucket inclines onwards, the bigger strength on the edge of bucket.

Adjust the height of lifting arm to lever up ground according to the job site. If to lift lifting arm, should keep the edge of bucket and ground parallel.

Note: Do not drive forward when lifting the lifting arm.

Backfill

Fall the lifting arm and close the edge of bucket to the ground. Drive forward to pit and pull the material into it. When exceed the edge of pit, should incline the bucket immediately. If necessary, lift the lifting arm and clean it.



WARNING

Fall the lifting arm as low as possible.

Do not drive or turn when lifting the arm.

Do not turn on flat ground.

Do not across slope.

The weight end of loader should be on the high direction of slope.

Do not operate overload.

Transportation of the loader

Procedure:

	WARNING
<p>The operation and maintenance must be carried out with the help of the experienced person. Pls read and understand the operation manual and sign(sticker). The repairing, adjustment and maintenance should abide by the warning and guideness in the manual after above-mentioned work, be sure that all functions are normal, otherwise, the failure may be occurred. (A)</p>	

Be sure the capacity and power of the vehicle for transporting the loader is correct.

While loading the loader, fix or hold the rear place of the trailer to avoid any danger. (B)

Place the right and left boards correctly and the boards should be strong enough to bear the loader's weight and also at the same level. Fix the boards on the trailer firmly. The max slope for the fixed board is 15 degree.

Follow the following steps to fix the loader on the trailer (C)

- Be sure the shovel or other attachment at the lowest position.
- Turn off the engine.
- Apply the strong rope or wire at front and back side.
- Fix the rope or wire on the trailer.

Lifting the Loader Procedure

Before lifting the loader, check its weight, length, width and height

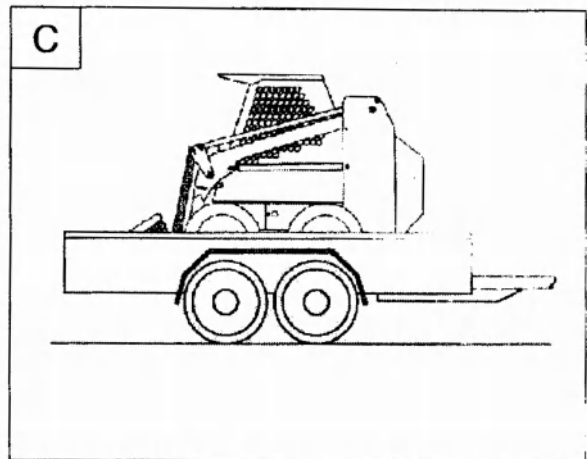
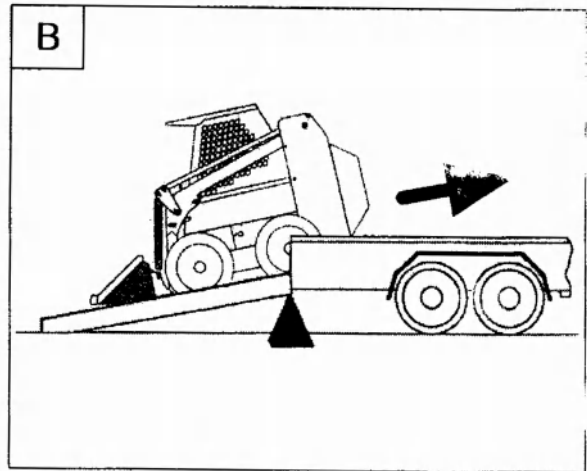
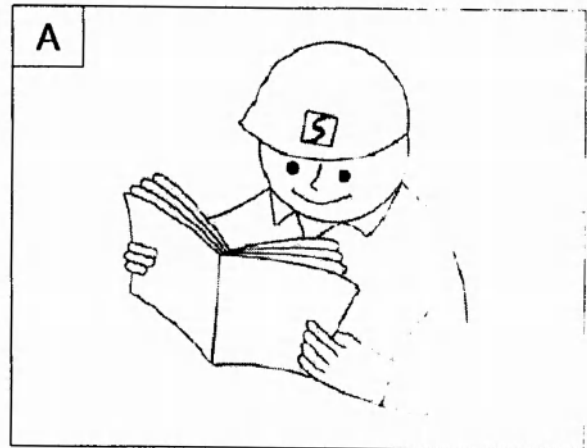

Use the correct chain or rope.

Fix the chain and rope at the correct place.

Put the rubber or other soft material on the surface where the chain or rope touch the loader to avoid any damage.

Attention: To avoid any damage of the gear mechanism system of the loader, the lifting distance should be short. (For instance, lift the loader to the transportation vehicle

---Be sure the chain or rope is strong enough.

---The wrong lifting way may cause damage of the loader .

---Don't make the sudden lift.

---After lifting the loader, it is not allow to be under it.

-

Assembly and disassembly of the attachment suspension frame

Assembly

The different attachments can be quickly displaced with the help of the suspension frame to meet different work requirement.



WARNING

For loading the loader the board must be strong enough. The wood one may not be recommended.



WARNING

While replacing the attachment, the handle at both side of the suspension frame should be held firmly and put down slowly, otherwise the operator may be injured.

While working, the suspension frame handle should be always locked.

Drive the loader to back side of the shovel.

Slope the suspension frame forwards and drive the loader slowly until the top surface of the suspension frame is completely in the weldment of the shovel or other attachments.

Don't make the pin shaft into the locking sleeve by the mean of hammering the handle of suspension frame.

Collect the suspension frame backwars until the shovel leave the ground, then turn off the engine.

Slowly put down the handle until the pin shaft is in the locking sleeve. The pin shaft must be completely in the locking sleeve.

Attention: If the pin shaft is not in the locking sleeve completely, the shovel or other attachments will be not safe.

	WARNING
The pin shaft must be completely in the locking sleeve, the handle should be put down and locked. If the shovel or other attachments can not be fixed firmly by the pin shaft, the injury of the people may be occurred.	

Disassembly:

Drive the loader at the leveling plate.

Lower the bucket to its lowest position. Tilt the bucket forward until the handle of the suspension can be lifted.

Screw out the locking bolt, hold the handle with hands and lift it until the pin shaft is out of the locking sleeve completely.

Tile the suspension frame is out of the weldment of the bucket.

Drive the loader backward and leave the bucket.

The attachment hydraulic System

	WARNING
While working, the hydraulic system and connection system of the attachments should keep clean.	



Connect the hose of the attachment to the hydraulic system of the loader with the help of a pair of quick coupler. Tight all nuts on the hydraulic system. The control pedal of the attachment.(2)

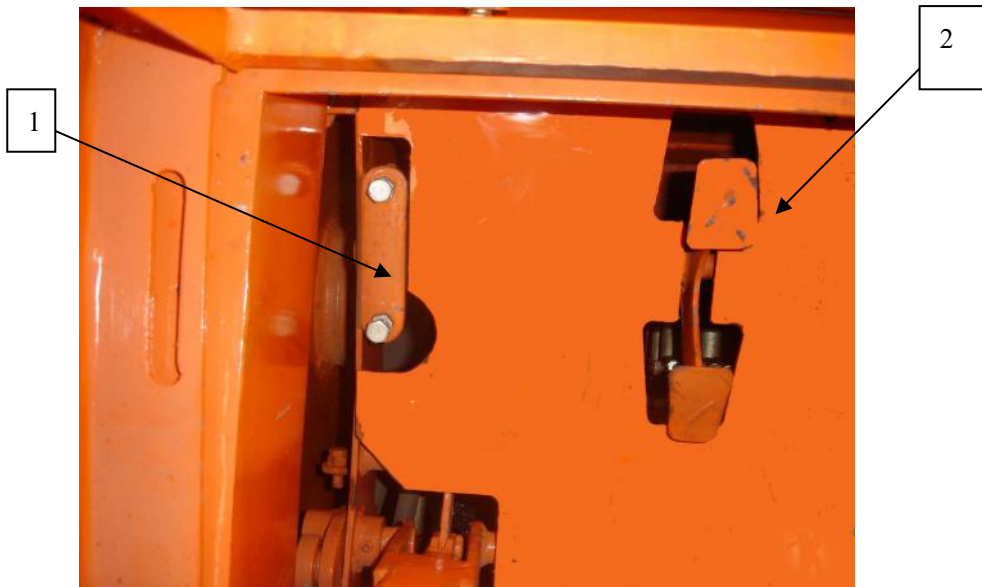

Open the nut and bolt (1),adjust the pressure of the hydraulic system and tight the nut and bolt.

Press the pedal at up position,the attachment cyliner will become long then the shovel close.In other hand,while press the pedal at down position,the cylinder becomes short then the shovel open(including fork shovel ,combined shovel and wood holder)

Safety maintenance



WARNING

Before operating or maintenance the loader ,read the manual carefully.Pay attention to the sign on the machine.While maintenance or adjusting,the warning or instruction in this manual must be obeyed otherwise the injury may be occurred.

Safety warning sign:Means:Warning!Be careful!For your safety!

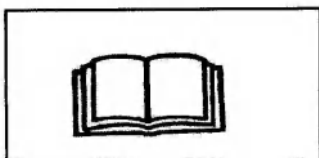

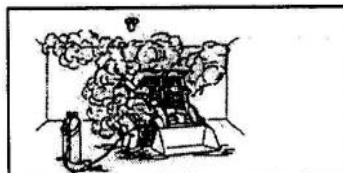
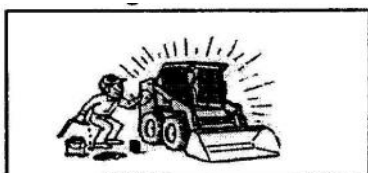

Don't repair the machine without this manual.

 Lift or lower the cabin with the correct operation.

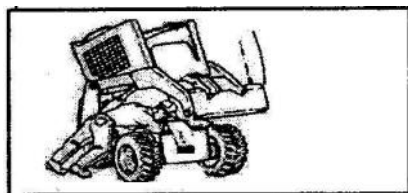

Daily clean and maintenance the machine.



 While weld or cut the painting parts,the working place should be full of air,the operator should wear mask.Avoid the smoke leakage from the exhaust system:The system should be smooth and complete.

Any disconnection of the pipe,hose or parts may cause the lowering of the arm.While the arms are lifted,it is not allowed to be under it.Replace the arm support if necessary.

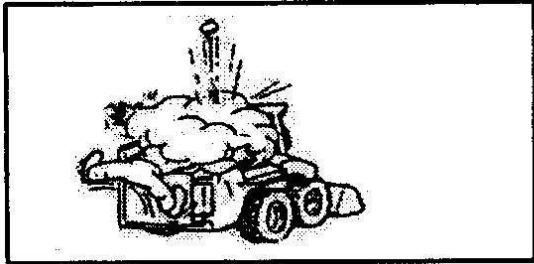
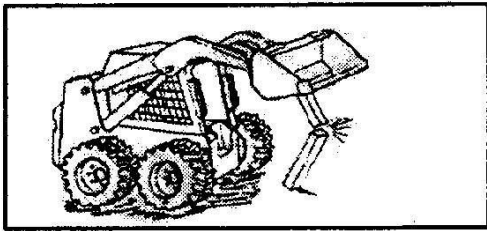

Before checking the oil way, first turn off the engine then cool and clean. Don't repair or adjust the machine while the engine is running. Don't touch the leaked oil or diesel unless there is such special instruction. The leaked oil or diesel may be harmful to eyes or skin. While adding the oil, the place should be far from fire or smoking area.

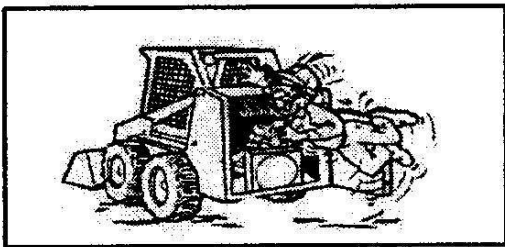

The body, jewelry and clothes of the operator should keep distance from the working parts, electrical parts, hot parts and exhaust system. While the engine is running, the operator should wear glasses to avoid battery acid or press liquid injuring eyes. While welding, the operator must wear stipulated glasses. Beside repairing, the rear cover of the engine must be kept close.

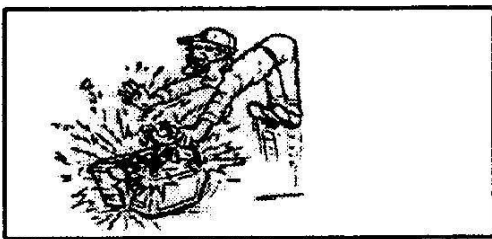

The battery acid may produce harmful air which may cause fire. Keep battery far from the fire. The battery acid may hurt eyes and skin. If there is acid on the skin, immediately clean with water or get Medical treatment.

The maintenance schedule

The maintenance should be applied within the certurn period. Otherwise the parts may wear out too fast. The maintenance schedule is the direction to repair ZJ loader correctly.



WARNING

Before operating or repairing the machine, it is very necessary to read and understand this manual. While repairing and adjusting, follow all warnings and instructions in this manual. After repairing and adjusting, check the machine correctly.

Maintenance Schedule

ITEM	Repair requirement	hours					
		8-10	50	100	*250	*500	*1000
Oil	Check the level of the oil if necessary,add oil.						
Air cleaner and air system	If necessary,check if there is any leakage or damaged parts						
Cooling system of the engine	Clean the dust in the cooler,radiator and water tank.Check the water level,if necessary add water.						
Safety belt,safety lever and foot pedal	Check the condition of the belt and lever,remove the dust on them.						
Meter and lights	Check the condition of them						
Cabin	Check all bolts,washers and nuts,check the condition of the cabin.						
Lifting arm,cylinder and shaft pin	Apply grease for lubrication						
Diesel filter	Remove water						
Pedal,manual controlling and steering lever	Check the working condition,if necessary,apply adjustment						
The rim nuts	Check the nuts,if loose,tighten them with 28-30kgf.m force.						
Steering shaft	Apply grease						
Hydraulic oil hose and pipe	Check the oil level,if necessary,add oil.Check if there is any damage or leakage,if necessary ,repair or make replacement.						
Driving case	Check the oil level						
Battery	Check the cable connection and the acid level,if necessary apply distilled water.						
Exhaust pipe	Clean the inner of the pipe						

The fan belt	Check the belt is tight or not,if necessary,make adjustment.						
Engine oil and filter	Replace the oil and filter,use the standard oil and filter.						
Diesel filter	Replace the element						
The driving belt of the engine	Check the condition,if necessary,make replacement.						
Transmission case	Check the grease level of the gear system,if necessary apply grease.						
Hydraulic oil tank	Replace the oil.						
Driving case	Replace the grease.						

Or after one year.

+ After 50 hours,make first time replacement of the oil and filter,then make further replacement after every 250hours.

LIFT ARM SUPPORT DEVICE

Engaging The Lift Arm Support Device



Maintenance and service work can be done with the lift arm lowered.If the lift arm raised,use the following procedure:

Put jack stands under the rear comers of the loader.

Remove the snap pin from the lift arm support device.

Lower the lift arm support device on top of the lift cylinder.

With the operator in the seat,seat belt fastened and safety bar lowered,start the engine.

Raise the lift arms,until the lift arm support device drops onto the lift cylinder rod.

Lower the lift arms slowly until support device is held between the lift arm and the lift cylinder.Stop the engine and raise safety bar.

Install pin into the rear of the lift arm support device below the cylinder rod.

Disengaging The Lift Arm Support Device

Remove the pin from the lift arm support device.

With the operator in the seat,seat belt fastened and safety bar lowered.

Take off the lift arm support device.

Raise the lift arm support device and insert the snap pin through lift arm support device.

Operator Cab

Description

ZJ loader has an operator cab as standard equipment to protect the operator from rollover and falling objects. Check with your dealer for the operator cab has been damaged. Operator cab is protective structure from falling bricks, small concrete blocks and hand tools encountered in operations such as highway maintenance, landscaping and other construction site service.

Also this is a protective structure from falling trees, rocks; for machines involved in site cleaning, overhead demolition or forestry.



WARNING

AVOID INJURY OR DEATH

When the loader is equipped with a enclosed cab (front door,backside windows and top window). The cab will not stay in the fully raised position.Use a chain hoist to secure cab in fully raised position or lower cab until it rests against the cab lock on the rear of the operator cab

Accidental movement of the loader,the lift arms or the attachment can occur if the lift or tilt control handles (steering control lever) are not positioned correctly before lifting or lowering the cab.

Move control linkage to top hole in handles,so cab does not hit handles when being lifted or lowered



WARNING

Never modify operator cab by welding,grinding,drilling holes or adding attachments unless instructed to do so by WOLF company.Changes to the cab can cause loss of operator protection from rollover and falling objects,and result in injury or death.

Raising the operator cab

- 1、 Stop the loader on a level surface.
- 2、 Lower the lift arms
- 3、 Stop the engine.The lift arms must be up when raising the operator cab.Install the lift arm support device.
- 4、 Put jack stands under the rear of the loader frame
- 5、 Loosen the bolt (both sides) at the front corner of the operator cab
- 6、 Remove the bolt and plate
- 7、 Raise the operator cab by hand
- 8、 Fixed the cab fixing plates well (both sides)
- 9、 Remove the jackstands

Lowering the operator cab

NOTE:Be sure the engine is stopped before lowering the cab.The safety bar must be fully raised or lowered when lowering the cab.Always use the grad handle to lower the cab.

Drag down the bottom of the operator cab till it contacts with the frame of the loader.

NOTE:Move both steering control lever to vertical position,so don't let the cab hit steering control lever when lifted or lowered

Install the bolts (both sides)

Tighten the bolts to (12-14.5 kg/m) torque

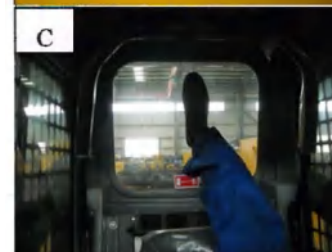

WARNING

Never modify operator cab by welding, grinding, drilling holes or adding attachments unless instructed to do so by Wolf company. Changes to the cab can cause loss of operator protection from rollover and falling objects, and result in injury or death.

Emergency Exit

The front door and rear window on the operator cab can provide exits.

To exit through the rear window, use the following procedure

- 1、 Remove the rubber cord around the rear window
- 2、 Push the rear window out of the rear of the operator cab with your foot

Exit through the rear of the operator cab.

NOTE: You can also exit through the front door on the operator cab.

SAFETY BAR

Use Of The Safety Bar:

The safety bar has a pivoting bar with arm rests.

The safety bar in the down position helps to protect the operator in the seat from serious rollover and impact from the outside.

Therefore, you must lower the safety bar and fasten it.

The safety bar will protect your safety in case that the loader will be overturned.

SAFETY BAR MAINTENANCE

Clean any debris or dirt from the moving parts inspect the linkage bolts and nuts.

If the safety bar does not function correctly. Check for free movement of each linkage part and excessive wear.

Replace parts that are worn or damaged

Use only genuine Wolf Company's replacement parts.





WARNING

Before you leave the operator's seat

- Lower the lift arms,put the attachment flat on the ground
 - Stop the engine
 - Raise safety bar and fasten it
 - Move the bucket and lift arm operation levers to the NEUTRAL POSITION
- Service the system if both levers are deactivated

SATEY BELT (If it is equipped)

When buckling the belt,make sure that it is not twisted and insert the plate on the right side into he buckle on the left until it clicks to the position.

If the belt length is short,lengthen the belt by adjusting it

If the belt is loose,pull the belt to eliminate any slack

When releasing the belt,press the button in the front of the buckle



WARNING

Always buckle the safety belt when operating the loader

Always make sure the safety belt is disconnected when leaving the operator's seat

AIR CLEANER

Cleaning the air filter (or element)

A dirty air cleaner will decrease engine output at worst.It will also increase the fuel

Consumption and the harmful contents of exhaust emissions and black smoke

So clean the air filter cyclically

Clean the air filter every 250 hours

Replacing the air filter

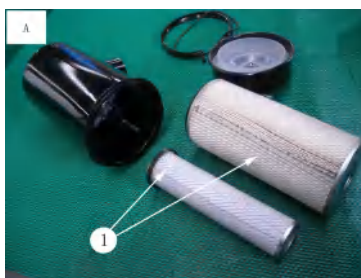

The period of replacement:every 1000 hours or after four cleaning

NOTE:when the engine is operated in dusty place

Shorten the cleaning intervals properly.

When clean the air filter,don't strike the air filter

Clean the air filter as follows:

- 1、 Remove the thumb nut from the dust cover
- 2、 Remove the dust cover
- 3、 Remove the thumber nut from the air filter bolt
- 4、 Take out the air filter

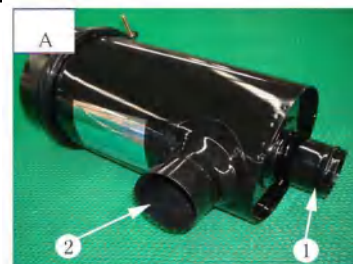

5、 Clean the air filter

Before installation, clean the inside of case, dust cover

Install the new air filter in the opposite order

NOTE: Make sure that a sealing surface are free of dirt and debris

Make sure that all coupling part are installed tightly

NOTE: Make sure that the air filter and dust cover are installed securely. If it is installed loosely, dust will be drawn in and the air cleaner will fail to function properly.

Filling The Fuel:

Use only clean, high quality diesel engine, Grade No.1 or No2

We recommend an operator to contact their fuel supplier for local recommendations

	<h1>WARNING</h1>
<p>Stop and cool the engine before adding fuel. NO SMOKING. Failure to obey warnings can cause an explosion or fire</p>	

Remove the fuel cap

Use a clean, approved safety container to add fuel of the correct specifications. Add fuel only in an area that has free movement of air and no open flames or sparks. NO SMOKING

Intall and tighten the fuel cap

Replacement of Fuel Filter

During operation, if the filter can not work properly, it must be replaced, otherwise it will shorten the engine life.

Loosen the plug:

Press the plug forcefully until the air comes out. Tighten the plug when there is no more bubbles inside the filter. Otherwise the fuel will be pressed out.

Finally check to be sure that there is no leakage of fuel.

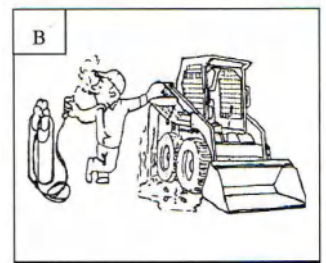

NOTE:

Do not smoke or have any other open flame near the engine while bleeding the fuel system.

Be sure to carefully clean away any fuel which spilled onto nearby parts coming out of the air plug, because such accumulations of fuel might ignite and cause a fire.

NOTE:

Diesel fuel or hydraulic oil under pressure can penetrate skin or eyes, causing serious injury or death. Do not use your bare hand. Wear safety goggles. If oil enters skin or eyes, get immediate medical attention from a physician familiar with this injury.

NOTE:

Once the oil comes out when working. Pay attention to avoid the fire.

NOTE:

Do not smoke when add fuel. Always clean up spilled fuel or oil. Keep heat, flames, sparks or lighted tobacco away from fuel and oil. Failure to use care around combustibles can cause explosion or fire.

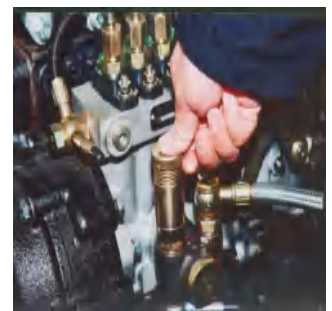

ENGINE LUBRICATION SYSTEM

Checking engine oil

Check the engine oil level every before starting the engine for the work shift. Check the dip stick. Keep the oil level between the marks on the dip stick. Use a good quality motor oil that meets (the oil chart below)

Oil chart

Kind of fluid	Capacity	Ambient temperature °C (F)					
		-20	-10	0	10	20	30
Engine oil	5.4L	SAE 30					
		SAE 10W					
		SAE 10W-30					
Hydraulic oil	58L	ISO VG 32					
		ISO VG 46					
		ISO VG 68					
Fuel	58L	ASTM D975 NO.1					
		ASTM D975 NO.2					
Coolant	Mixture of antifreeze and water 50:50 9L	Ethtyen plycol base permanent type					
Grease	As required	NLG1 NO.1					
		NLG1 NO.2					

Only use oils of the specifications above or similar.

Oils of different brands can not be mixed.



WARNING

If the oil is contaminated or diluted, change the oil regardless of the regular change interval

Check oil level after engine has been stopped for 15 minutes. ◦

Replacing engine oil and oil filter

Warm up the engine and then stop the engine.

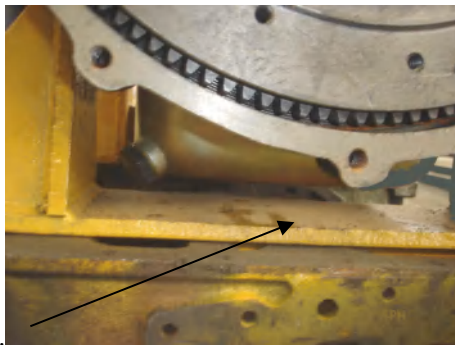

Remove drain bolt.

Drain the oil into a container and dispose of used oil in an environmentally safe manner.

Replace the oil filter, clean the oil outside the filter and tighten the lap



NOTE: mechanical over-tightening may distort the threads or damage the filter element.

Install and tighten the drain bolt

Remove the filter cap from the engine upper frame. (see picture)

Fill the engine with clean oil according to the requirement

Start the engine and let it run for several minutes then stop the engine

Check for the leakage of the oil filter and check the oil level.

Clean it

Add oil as needed if oil indication is not between the bottom mark and the top mark on the dip stick.



ENGINE COOLING SYSTEM

Check the cooling system every day to prevent over-heating, loss of performance or engine damage



WARNING

If the radiator must be replaced due to bent or broken fins which can cause the engine to overheat, refer to the manufacturer's replacement procedure.

Structure of cooling system

Cooling system ass'y is composed of oil cooler, radiator, overflow hose, radiator cap, water inlet hose, water outlet hose.

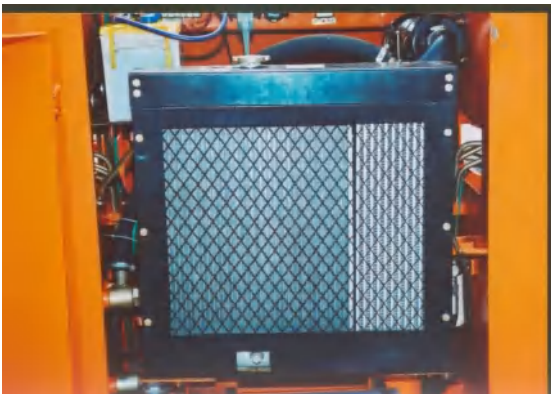

Checking the coolant level

Open the engine room cover, check the coolant level in the coolant recovery tank, if the coolant is low, fill clean water into the radiator

Cleaning the water oil radiator

Check the surface of the water oil radiator, if necessary, clean and dry the surface of the water oil radiator, if the loader works under dirty environment, clean the radiator more frequently, the step is as follows:

1. Open the engine room cover
2. Inspect the radiator ;
3. Use air pressure to blow the dirt and debris from the core. At this time, blow the air in the opposite direction of the fan air flow.
4. Inspect the radiator for bent or broken fins.
5. Check cooling system for leakage

Replacing The Coolant

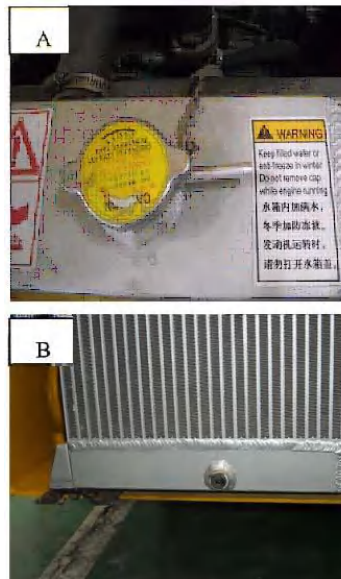

WARNING

Do not remove radiator cap when the engine is hot. You would be seriously scalded.

- 1、 Open the engine room cover
- 2、 Remove the radiator cap
- 3、 Open the drain valve and drain the coolant into a container

After all the coolant is removed, tight the drain valve

Mix the coolant in a separate container

NOTE: The loader is factory filled with monoethylene glycol coolant. Do not mix monoethylene glycol with propylene glycol

Add premixed coolant, 50% water and 50% monoethylene glycol to the reservoir in case the coolant level is low.

One gallon of monoethylene glycol mixed with one gallon of water is the correct mixture of coolant to provide -37.3°C freeze protection

Use a refractor-meter to check the ratio of monoethylene glycol and water in your cooling system

Fill the radiator with the premixed coolant.

Fill the radiator to one third

Tight the radiator cap

Run the engine until it is at operating temperature,then stop the engine.

Check the coolant level and add coolant into radiator if need



IMPORTANT

AVOID ENGINE DAMAGE

Use the correct ratio coolant

Too much coolant will effect the efficiency of the cooling system and may cause serious premature engine damage.

Too little coolant will effect the engine and can not protect it well,it will reduce the boiling point and damage whole system

Add full strength concentrated coolant can cause serious premature engine damage.

FAN BELT

Fan Belt Tension

Stop the engine

Open the engine room cover

check the tension by pressing the center of the fan belt with your thumb(10kgf)

Proper flexure of the fan belt is 10-15mm

If the tension is too high,the fan belt will be worn

Adjust the fan belt tension by looseing and moving the alternator fixing bolt and adjusting bolt

Do not allow oil to deposit on the fan belt because the fan belt slips and is early elongated

Replace the damaged fan belt and close the engine room cover

HYDRAULIC OIL

Cleaning hydraulic filter

Lower the lift arms,ground any attachment.

Stop the engine and then leave for 5 minutes

Remove the filter cover

Clean the filter head contact surface

Clean the filter by solvent or replace it

Install and tighten with O-ring

Fill some oil to filter element and gasket surface.

Replacing Hydraulic Oil

The oil must be replaced if it is contaminated or repaired

NOTE:If the HYD'oil tank is not clean,it may cause damage to hydraulic system



Replace the hydraulic oil according to the following procedure

- 1、 Stop the loader on a level surface
- 2、 Lower the lift arms and tilt the bucket fully back
- 3、 Stop the engine and then leave for about 5 minutes
- 4、 Remove the drain bolt (item 1) and drain all fluid from the HYD' oil tank. After finishing it, then tight the drain bolt.



WARNING

Hydraulic oil escaping under pressure can have sufficient force to enter a person's body by penetrating the skin and cause serious injury and possibly death if proper medical treatment by a physician familiar with this injury is not received immediately



WARNING

Always clean up spilled fuel or oil. Keep heat, flames, sparks or lighted tobacco away from fuel and oil. Failure to use care around combustibles can cause explosion or fire which can result in injury or death

Replace hydraulic oil

Loose the oil bolt

Remove the hydraulic oil cap

Fill the hydraulic oil till the oil overflow through the oil level bolt

Tight the oil bolt and oil cap

Start the engine and check if the hydraulic system works properly

Stop the engine, Check for the leakage



CHAIN CASE

Check the oil of chain

After checking the chain case, add gear oil as following procedure

- 1、 Stop the loader on a level ground
- 2、 Stop the engine and let the oil settle for a few minutes
- 3、 Loose the oil bolt (1)

If oil just starts flowing out when the bolt is removed, then the oil level is correct. If not, remove the oil cap (1) [C] and fill the oil till the oil starts flowing out through oil level bolt

- 4、 Tight the oil bolt and cap

Changing oil

- 1、 Lower the lift arms and ground any attachment
- 2、 Stop the engine and then leave for 5 minutes
- 3、 Remove the drain bolt (1) [B], and drain the oil into a container.
- 4、 After draining the oil completely, install the drain bolt and tight it
- 5、 Remove the oil bolt (1) [A] and oil cap (1) [C]

Fill oil as needed till the oil starts flowing out through oil level bolt

Tight the oil bolt and install the oil cap



A

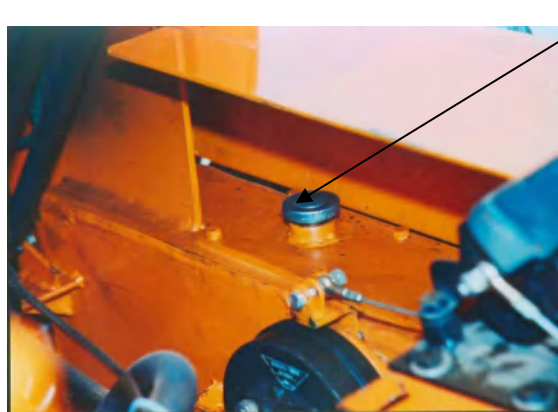

C



B

LUBRICATION

Procedure

Grease the loader as specified in the SERVICE SCHEDULE page 48 for the best performance of the loader

Fill the lubricant until extra grease flows out

Record the operating time each time your grease the loader

Pls use good quality SPHEEROL EPL-2 of CASTROL to grease the loader

Grease the both side 12nipple points (1) [A] on the loader every 8-10 hours or daily

Grease other pivot point, every 50 hours lubricate the arm of some jack-up(both ends), the upper part of the lifting cylinder, the lower part of the lifting cylinder, the bucket cylinder etc

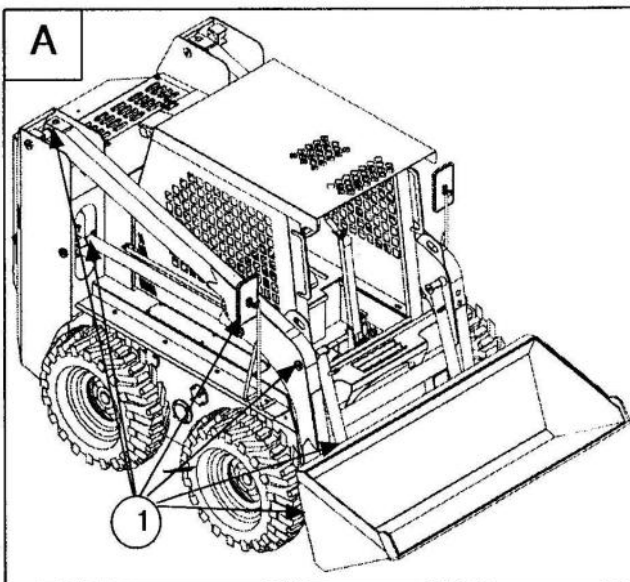

Grease fitting location

Grease the following locations (nipples) on the loader before operating. Wipe dirt from the fittings before greasing them to prevent contamination. Replace any missing or damaged fitting. To minimize dirt build-up, avoid excessive greasing.



QUICK COUPLER

Inspection and maintenance

Move the levers to engage the wedges. The levers and wedges must move freely. The wedges must extend through the holes in the attachment mounting frame (1) [A]



WARNING

Quick coupler wedges must extend through the holes in attachment. Levers must be fully down and locked. Failure to secure wedges can allow attachment to come off and cause injury or death.

The wedge (item 1) must contact the lower edge of the hole in the attachment. If the wedge does not contact the lower edge of the hole, the attachment will be loose and can come off the loader.

Inspect the flange on the attachment and the quick coupler, linkages and wedges for excessive wear or damage.

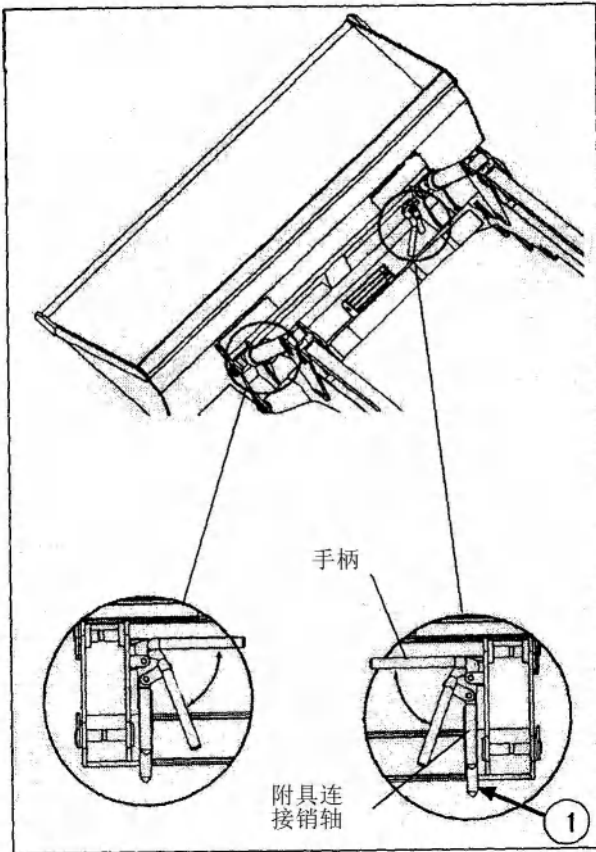

Replace any parts that are damaged, bent or missing. Keep all fasteners tight.
 Pls contact your dealer for repairing or replacement parts.
 Lubricate the wedges.

ELECTRICAL SYSTEM

Wiring and gauges

Check regularly and repair loose or malfunction gauges when found

Battery

Keeping the battery and treatment

Note: ZJ skid steer loader is equipped with the wet-charge typed battery

Keep the battery at a cool area where air is well ventilated. Do not expose the battery under a direct ray and avoid

humid area. Don't hit it with metal tools when installing. Don't place metal tools on the upper part of the battery. Wash the terminal with hot water if it is contaminated, and apply grease to the terminals after washing.

Inspecting electrolyte

Disconnect the cable of the battery.

Loosen the vent plug

Check for a amount of electrolyte in each cell

Inject regulation rated-distilled water when the level of electrolyte is below "the lowest limit"

Safety instructions

Wear proper personal safety tools (safety goggles, rubber gloves, etc) called for by job or conditions when handle the battery.

Handle it carefully because it contains sulfuric acid

Wash out sulfuric acid immediately with which skin or clothes is stained, otherwise it can cause serious injury or death.

Keep the battery away from flames or heat

Use the battery only for the purpose of starting the engine, otherwise it can cause the battery to be damaged or flames by hydrogen gases which are generated from the battery.

Removal and installation

Stop the engine and pull the start key out

Disconnect the cathode cable first

Disconnect the anode cable later

Loosen the fixing bolts and remove the battery

Confirm directions of terminal on the battery which will be installed

Reverse the removal procedure of the battery to install it exactly

Note: be sure that you should not connect each cathode anode terminal in the opposite place

Tighten the M5 terminal to 20-30 (kgf-cm) torque and M6 terminal to 40-60 (kgf-cm) torque

Handling the battery in winter

While the battery needs a higher voltage and more sufficient electric current to start the engine especially in winter than other seasons, the slow diffusion of electrolyte due to low temperature can cause the battery to fall its capacity for supplying an electric current. That is why it is more difficult to start the engine in winter than summer.

Don't keep the battery being electric discharged

Never try to restart the engine immediately when you can not start it with only one try. It needs more about 1 minute to restore a voltage

Inspect and maintain the battery lineage especially in winter.

Warning: never start the engine by means of the battery of other vehicles in case the loader's battery is discharged electricity and electrolyte is frozen.



MUFFLER

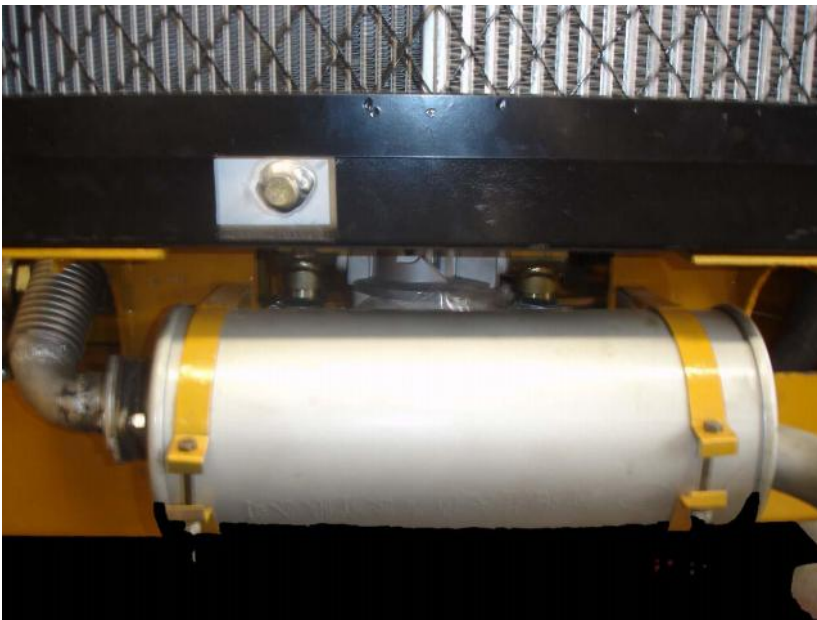

Muffler maintenance

Do not operate the loader with a defective exhaust system

Stop the engine. Open the engine room cover and rear grill

Make a visual inspection of the muffler and replace the damaged muffler with new one, if there are holes and cracks on the muffler.

Lower the rear grill and close the engine room cover

Note: when the engine is running during service, the steering control lever must be in neutral. Failure to do so can cause injury or death.



WARNING

When an engine is running in an enclosed area, fresh air must be added to avoid concentration of exhaust fumes. If the engine is stationary, vent the exhaust outside. Exhaust fumes contain odorless invisible gases which can kill without warning

Stop the engine and allow the muffler to cool before checking for the muffler. Wear safety glasses or goggles. Failure to obey can cause serious injury

Never use machine in atmosphere with explosive dust or gases or where exhaust can contact flammable material. Failure to obey warnings can cause injury or death.

TYRE



Tyre pressure

Check the tyre when tire is at normal temperature and the machine is not loaded

Inappropriate tire pressure is a primary cause for tie damage. Insufficient tyre pressure will damage internal carcass of tire. Excessive tire pressure will also cause premature damage of tyre.

Continuous operation will produce heat and increase pressure on tire. but such phenomenon was already taken into account when designing a tyre. Do not try to remove normally increased air because tires may be crushed or overinflated

The three major causes for excessive heat and pressure of tire are insufficient pressure, excessive load and overspeed.

Avoid excessive load and overspeed in order to keep tyres in good shape

Recommended tire pressure when tyre is normal condition

Size	pressure
10x16.5	2.4 Bar(35Ps)

tyre rotation

check the tyres regularly for wear, damage and pressure

rear tyres usually wear faster than front tires. To keep both of front rear wear equally, exchange the front tyres for the rear and rear tires for the front periodically

it is important to keep the same size tires on each side of the loader. If different sizes are used, each tyre will be turning at a different rate and cause excessive wear. The thread bars of all the tyres must face the same direction

recommended tire pressure must be maintained to avoid excessive tire wear and loss of stability and handling capacity. Check for the correct pressure before operating the loader

wheel nuts

check torque on all wheels to prevent shearing of the wheel studs and wheel damage

the correct torque is 28-30 kgf.m torque

replace damaged wheel

tyre maintenance

tyres are to be repaired only by an authorized person using the proper procedures and safety equipment. Tyres and rims must always be checked for correct size before mounting, otherwise it is easy to be damaged

the rim flanges must be cleaned and free of rust. The tyre bear and rim flange must be lubricated before mounting the tyres. avoid excessive pressure which can rupture the tyre and cause serious injury or death. During inflation of the tyre, check the tyre pressure frequently to avoid over inflation

storing tyres

As basic rule, store tyres in a warehouse where unauthorized persons can not enter. If tires are stored outside, always erect a fence around tyres and put up “NO ENTRY” and other warning signs that even young children can understand

Stand the tyre on level ground, and block it securely so that it can not roll or fall over.

If the tyre should fall over, get out of the way quickly. The tyres for construction equipment are extremely heavy, so trying to hold the tyre may lead to serious injury.

Use only above oils listed or equivalent.

Do not mix different brand oil

TROUBLE SHOOTING-ENGINE

This trouble shooting is not intended to cover every conditions, however many of the more common possibilities are listed

Trouble	service	Remark
Engine oil warning light fails to go off immediately after the engine is started	Add the oil to the specified level Replace the oil filter Check oil leakage from the tube or the joint	
Steam is emitted from the top part of radiator (the pressure valve)	Supply the cooling water and check leakage Adjust the tension of fan belt Clean outside of cooling system Clean or repair the radiator fin Check the thermostat Check the engine cooling water temp, gauge Tighten the radiator cap firmly or replace the gasket of it	
Engine does not start when the starting motor is turned over	Repair where air is inhaled into fuel system Check the injection pump or the nozzle	
Exhaust gas is white or blue	Check the valve clearance	
Exhaust gas occasionally turns black	Adjust the oil level to the specified level Replace the fuel Clean or repair the air cleaner filter Check the nozzle	
Combustion noise occasionally change to breathing sound	Check engine compression pressure	
Unusual combustion noise or mechanical noise	Check the nozzle Check the injection pump Replace the fuel Check overheating Check the muffler Check the valve clearance	

TROUBLE SHOOTING-ELECTRICAL SYSTEM

Trouble	service	Remark
Starting motor does not turn when main switch is turned on	Inspect and repair the wiring Charge the battery Inspect the main switch	
Starting motor turns the engine sluggishly	Charge the battery Inspect the starting motor	
Starting motor disengages before the engine starts up	Check and repair the wiring Charge the battery	
Engine oil warning light does not light up when engine is stationery (when the main switch is “ON” position)	Inspect the warning light	
Charging warning light does not light up when engine is stationery (when the main switch is “ON” positon)	Inspect the warning light Check and repair the wiring	

TROUBLE SHOOTING-HYDRAULIC SYSTEM

Trouble	service	remark
Bucket lifting speed is slow Bucket lacks lifting power	Check the hydraulic oil level and add if necessary Replace filter on rear	
Rubbles in oil	Replace oil Add oil if needed	
Oil pressure is low	Bleed air from oil line Add oil and bleed air	
Cylinder vibrates when operating	Add oil	

Safety alert symbol

This safety alert symbol means: “ATTENTION” BECOME ALERT” “YOUR SAFETY IS INVLOVED”

The safety alert symbol identifies important safety message on machines,safety signs in manual or elsewhere.when you see this symbol,be alert to the possibility of personal injury or death.Follow the instruction in the safety message

Safety operation manual

Foreword

this safety manual is intended to point out some of basic safety situations which may be encountered during the normal operation and maintenance of your machine and to suggest possible ways of dealing with these conditions

additional precautions may be necessary, depending on attachments used and conditions at the worksite or in the service area. The manufacturer has no direct control over machine application, operation, inspection, lubrication or maintenance. Therefore it is your responsibility to use good safety practices in these areas

this information provided in this manual supplements the specific information about your machine that is contained in the manufacturer's manual. Other information which may affect the safe operation of your machine may be concerned on safety signs or in insurance requirements, employer's safety programs, safety codes, local laws, rules and regulations.

Important: if you do not have the manufacturer's manual for your particular machine, get a replacement manual from your employer, equipment dealer or from the manufacturer of your machine. Keep this safety manual and the manufacturer's manual with your machine.

It is your responsibility to read and understand this safety manual and the manufacturer's manual for this machine. This safety manual takes you step-by-step through your working day.

In reading this manual, you will note that any illustration depicting an unsafe work procedure or illustration is labeled both with the word "wrong" and the mark of an "X" on the illustration. Each illustration is also numbered and the same number appears in the text in parenthesis. This number is placed at the end of the written text that refers to the illustration

Remember that you are the key to safety. Good safety practices not only protect you but also protect the people around you. Study this manual and the manufacturer's manual for your specific machine. Make them a working part of your safety program. Keep in mind that this safety manual is written for only this type of machine. Practice all other usual and customary safety working precautions, and all –

REMEMBER SAFETY IS UP TO YOU

YOU CAN PREVENT SERIOUS INJURY OR DEATH

FOLLOW A SAFETY PROGRAM

Protect yourself

Wear all the protective clothing and personal safety devices issued to you or called for by job condition

You may need:

safety hat

Safety shoes

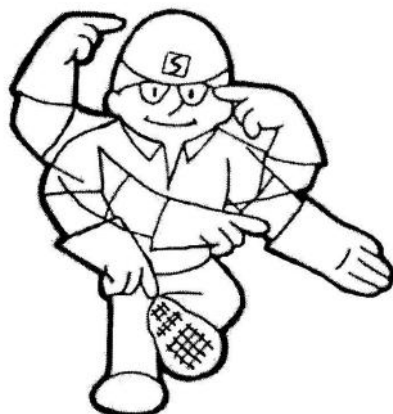

Safety glasses,goggle,or face shield
Heavy gloves
Heating protection wear
Reflective clothing

Filter mark

Wear whatever is needed,do not take chances (1)

 Warning: do not wear loose clothing or any accessory flopping cuffs,dangling neckties and scarves,or jewellery and wrist watches that can catch in moving parts (2)

Be Alert

Know where to get assistance. Know how to use a first aid kit and fire extinguisher/fire suppression system

Be Aware

Take advantage of training programs offered

Be careful

Human error is caused by many factors: carelessness,fatigue,overload,preoccupation,unfamiliarity of operator with the machine,drugs,and alcohol to name a few. Damage to the machine can be fixed in a short period of time. But injury or death ,has a lasting effect. For your safety and the safety of others,encourage your fellow workers to act safety.

For safe operation of this machine,you must be a qualified and authorized operator.To be qualified,you must understand the written instruction supplied by the manufacturer,you must be trained including actual operation of this machine and know the safety rules.

Most employers know the rules of operation and maintenance of equipment,before you start work at a new location,first ask your supervisor or the safety coordinator about the rules which you should obey.(3)

Warning:

Do not operate this machine if your are under the influence of drugs or alcohol which can impair your alertness or coordination.An operator on prescription or over-the-counter drugs needs medical advice on if he can safety operate machine

You must obey some rules

- Know the capacity and operating characteristics
- Never modify or remove any part of the machine (except for service and reinstallation before operating)

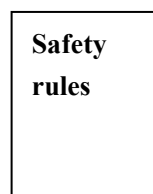
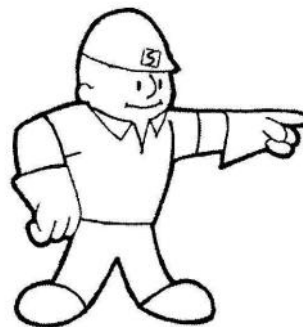

3

- Fasten your seat belt before starting
- Keep others away from your machine
- Look before you backing up
- Carry the load lower
- Whenever you leave your machine,always lower the lift arms and put the bucket or attachments flat on the ground or lock the lift arms with the lift arm restraint devices.Stop the engine,cycle the hydraulic controls to eliminate pressure,and remove the key before you dismount (see page 17)

Make sure you understand the traffic rules at your jobsite.Make sure you know all signs flags and mark meaning.

Follow a safety program

Know your equipment

Know your skid-steer loader. Know how to operate your machine. Know the purpose of all the controls,gauges and indicators. Know the rated load capacity,speed range,braking and steering characteristics,turning radius,and operating clearance.

Keep in mind that rain,snow,ice.loose gravel,soft ground,etc,change the operating capabillities of your machine.

Study the DANGER,WARNING,safety signs on your machine and the information signs.

Read and understand the manufacturer's operator's manual before starting the engine.Is there is no manual with the machine,get one study it before you start working If there is something in the manual you don't understand,ask your supervisor or equipment dealer to explain it to you.

If your machine is equipment with other attachments.read the manufacturer's operating and safety manuals pertaining to that equipment before using it.

To protect you and others around you,your machine may be equipped with the following safety equipment.

- FOPS (Falling object protective structure)
- ROPS(Rolling object protective structure)
- safety belt
- safety bar
- grab handle
- life arm support device
- lights
- guard
- warning strokes
- lock device

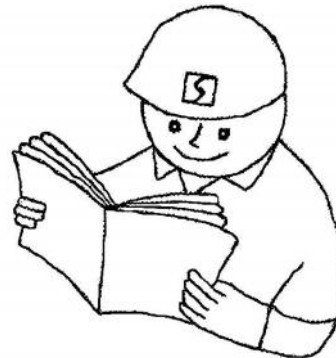

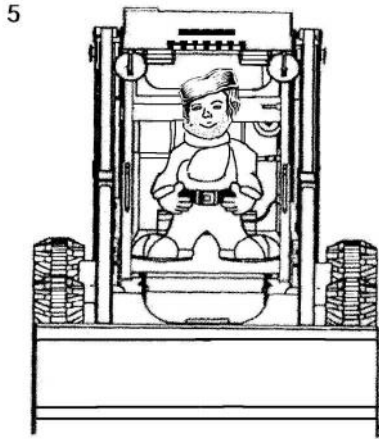

Never remove or disconnected any safety device

•
Check the machine

Before you begin your work ,you must inspect your machine accoring to the following procedure

- check for broken,missing or damaged parts make necessary repairs
- check if the tyres are in good condition
- check the brake for proper operation
- perform all maintenance procedures outlined by the manufacturer of your machine
- check the hydraulic system.for any leakage

Note: pls check if the fuel or hydraulic oil is leaky before operating the machine

Note: lower the lifting arm and stop engine before cleaning loader

Make sure the operator's area,steering levers,pedals,steps and grab handles are clean(7).oil,grease,snow,ice,mud or debris in these areas can exause you to slip and fall.clean your boots of excess mud before getting on the machine

6

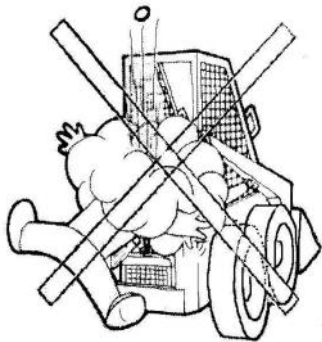

wrong

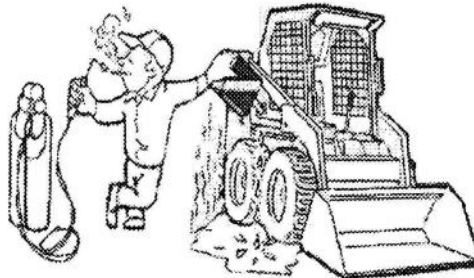

wrong

SAFETY MANUAL

-Check cooling system.

Warning:check the coolant level before the coolant becomes cool

Warning:Never fill the fuel tank with the engine running,do not smoke or stand under the lifting arm

Never overfill the tank or spill fuel.if fuel is spilled clean it up immediately

Be sure to use the correct type and grade of fuel

If the oil tank or the nozzle is damaged,pls replace them

Know The Working Area

Learn beforehand as much about your working area as possible,check if there are rocks,sand on the ground.also check if the ground is muddy or soft to avoid the wobble of the loader and keep the control to the loader. During operating your machine,you have to know the specification of your loader,including the maximum load etc.

In your working area,you should check the ground carefully in case that the eye can puncture the tyres (8)

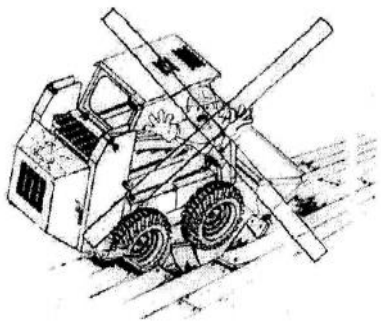

8 wrong

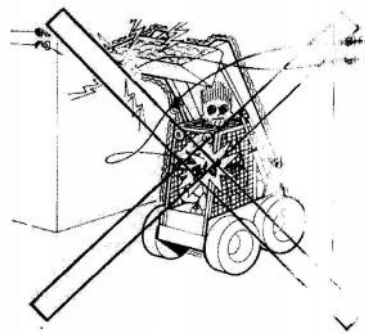

9 wrong

Before operating,pls check where the loader will lift and turn. You have to know the load data of it.

Do not remove any parts of the loader,do not let the electrical wire contact the bucket of the loader (9),before operating,you should check all kinds of wires in your working area

Rules of the road

Make sure lights and warning signs are available on your loader, the sign of “slow moving” must be available on the rear of the loader.

When traveling on public roads,you should use the indicator light.Place the bucket in the transportation position. observe speed and traffic control signs avoid panic stop and turn (10).Keep the rear indicator light on,it means other vehicles could pass.If you want to stop at roadside,you can use the horn and the rearview mirror.if drive at night,you should use the light.(11)

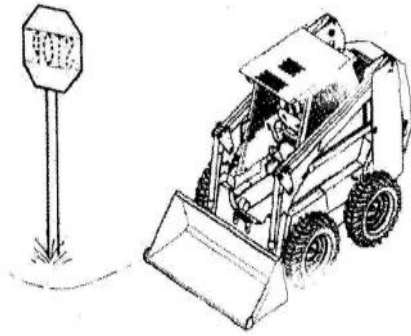

10 right

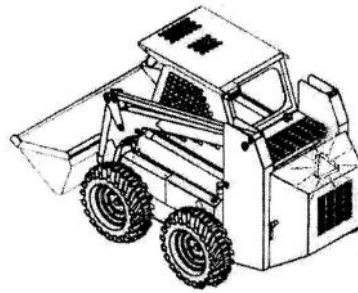

11 right

Start safely

Mount safety

Never mount a machine unless the life arms are lowered or restrained by a lift arm restraint device

When you get on or leave the machine always obey the following procedures:

- maintain a three point contact with the steps and grasp handles provided
- face the loader
- never jump on or off the machine never attempt to mount or dismount a moving machine



12 right

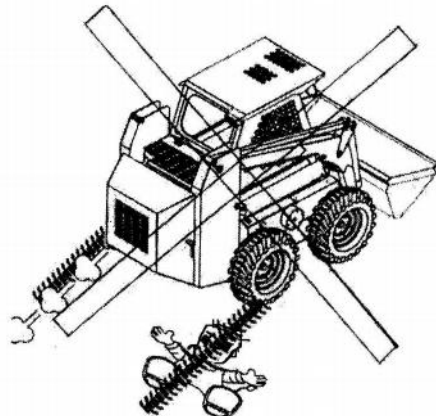

13 wrong

Do not use a steering of control lever as a hand held when you enter or leave the machine

Warn other person before starting

Before starting the machine make sure no one is under the machine or close to it. Let other workers and bystanders know you are starting the machine, otherwise don't start it.

Starting the engine

Warning: the driver only can start the engine when he sits on the driver's seat. Never attempt to start the engine by other method, if the machine move uncontrollably, it will cause serious injury or death to anyone. (14)

Know the exact starting procedure for your machine Read the manufacture's manual's for starting before operating the machine

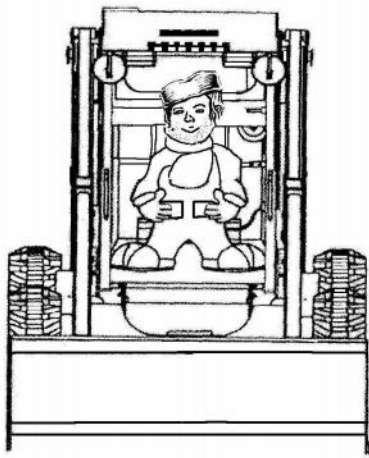

14 right

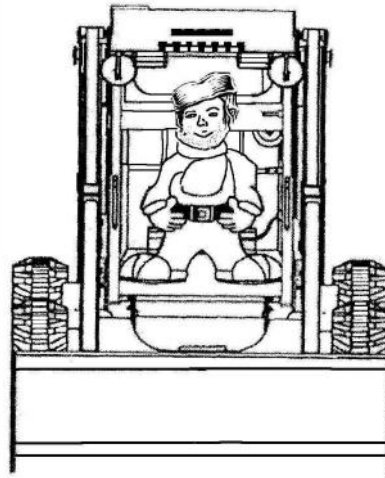

15 right

1. sit on the operator's seat and adjust the seat so you can operate all the controls properly
2. fasten the safety belt (if it is equipped) (15)
3. familiarize yourself with warning devices, gauges and operating controls
4. lower the operator bar (if it is equipped)
5. engage the brake and put all controlling instruments in the neutral park position
6. clear the area of all persons
7. start the engine following the instructions in the manufacturer's manuals

if necessary to run the engine or operate the machine in an enclosed area, be sure there is adequate ventilation.

Warning: A battery explosion or a run-away machine could result from improper jump starting procedures

Warning: do not use ether if the engine is equipped with glow plug type preheater or other intake manifold type preheater. it could cause an explosion or fire and severe injury or death

After starting engine

Observe gauges, instrument and warning light to assure that they are functioning and their readings are within the operating range.

Run an operating inspect

Do not use a machine if it is not in proper operating condition. It is the operator's responsibility to check the condition of all systems in a safety area

Test control system

Make sure the engine is operating correctly

By the control levers in neutral to test engine speed control system

Operate each control pedal or lever to make sure all lift arm and bucket's functions are correct

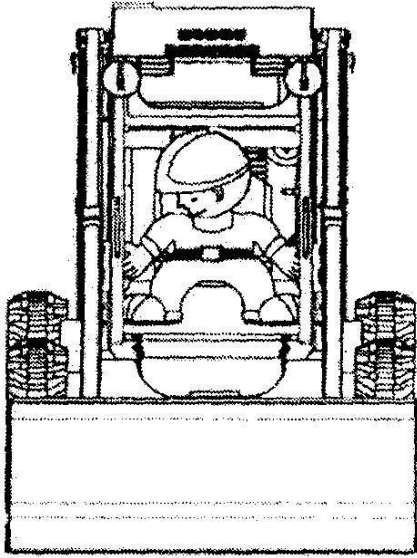

16 right

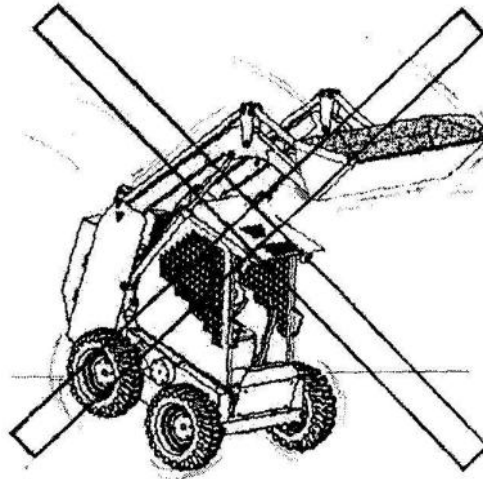

17 wrong

Start safely

Test control system

Warning: make sure that you can control both speed and direction before moving

Operate the travel control lever(s) well to ensure forward and reverse . Test steering-forward and reverse or right and left-while moving slowly in a clean safety area

Work safely

Remember the following rules

Do not overload the bucket or other attachments or carry a load which can fall from bucket or other attachments (Fig17)

Different attachments can change the weight distribution of the loader they can also effect its stability and handing response,be sure you can keep the loader under complete control

Warning: never modify your loader's pros (roll-over protective structure) to avoid the severe injury or death

When changing bucket or installing attachment.make sure all connection securely fastened and tight all bolts,nuts and screws to the torques recommended by the manufacturer

Prohibit operating the machine except driver

Never allow an untrained or unqualified person to operate your machine because it could cause severe injury or death (18)

Warning: your loader is one person machine,never allow many persons to operate

Never use the bucket as a work platform or personnel carrier



18 wrong

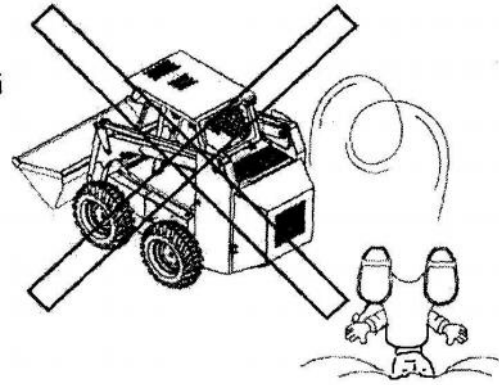

19 wrong

Always look around before you back up, or swing an attachment. Be sure that everyone is in the clear. Know the pinch points and rotating parts on the loader; awareness on your part can prevent accidents. Never overload the bucket with material which can injure someone if it spills. Keep loaded bucket level as lift arms are moved and as loader moves a load over anyone (Fig 20). Keep others away from your operation.

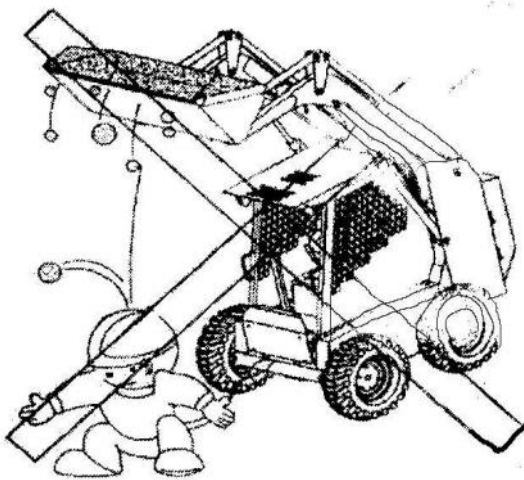

20 wrong

Follow safety operating practices

- fasten your safety belt
- never leave the operator's seat without first raising the operator seat bar if so equipped, lower the lift arm or engaging the lift arm restraints and stopping the engine.
- operate the control system smoothly
- do not pull the steering levers suddenly
- carry the load low
- suddenly stop, start and turn is not allowed
- use carefully and good judgement
- never attempt to operate unless properly seated (Fig 21)

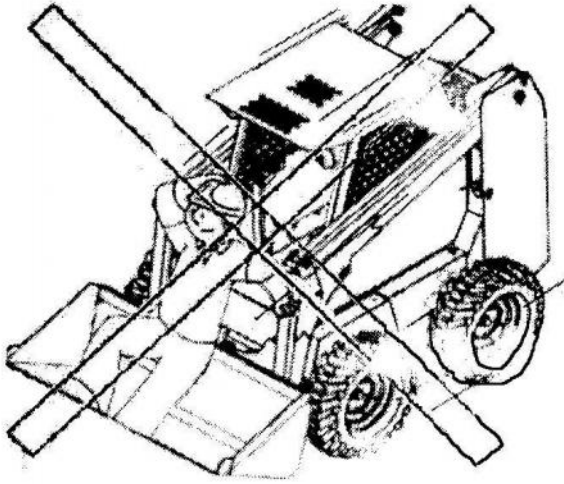

Fig 21 wrong

warning: keep your body inside the operators's cab while operating the skid steer loader.never work with your arms,feet or legs beyond the operator's compartment

Keep alert all the time. If something is broken,come loose,or fail to operate on your loader,stop work,lower the lift arms,stop the engine and inspect the machine.

Operate safely

Always keep the lift arms down when traveling or turning.When the loader loads,unloads and turns,it should be on flat level ground.

Never ram the bucket into a matetial pile,most loaders have force at slow speeds

When traveling over rough terrain,slow down to prevent losing control

False loads slowly at an even rate and be ready to lower load quickly if loader gets in unstable situation

Avoid steep slopes or unstable ground. If you must drive on a slope.keep the load low and proceed with extreme caution.Do not drive across an excessively steep slope under any circumstances.(Fig 22)Travel straight up and down the slopes

Warning: travel up and down on slopes as follow: travel up and down slope with the heavy end of the loader pointed uphill

Loaded bucket: with bucket load pointed uphill

Empty bucket: with bucket pointed downhill

Warning: do not dump while raising the lift arm.if you do so,it can cause lift arm to be dropped (Fig 23)

Follow the manufacturer's recommended dumping procedures

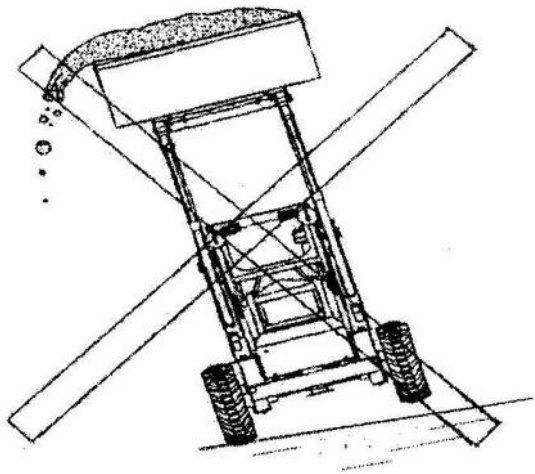

Fig 22 wrong

-raise the lift arm

-put control level in the neutral position

-dump

when you dump the raising material you have to operate elaborately and dump a little

traveling on jobsite

take it slow and easy when traveling through congested areas.traffic courtesy pays off.

Drive the loaded machine properly and keep a safe distance from other vehicles pass cautiously

Don't obstruct your vision when traveling or working, Carry the bucket low for maximum stability and visibility while traveling at speeds slow enough so you have complete control at all times,travel slowly over rough or slippenry terrain and hillsides.

According to the loader manufacturer's recommendations, most loaders are heavier on the rear axle when unloaded and heavier on the front axle when fully loaded

If you are working on a ramp or slope, it should always have a flat,level turn-around area so you can turn,load and unload safely

Warning: keep the load as low as possible for maximum stability

The barycenter of your skid steer loader shifts as loads are lifted and lowered.never attempt to make sharp turns or travel on steep slopes with raised load (Fig 24)

Warning: make sure you can see where you are going.Never travel with a load obstructing your vision

Watch out for hazardous working conditions

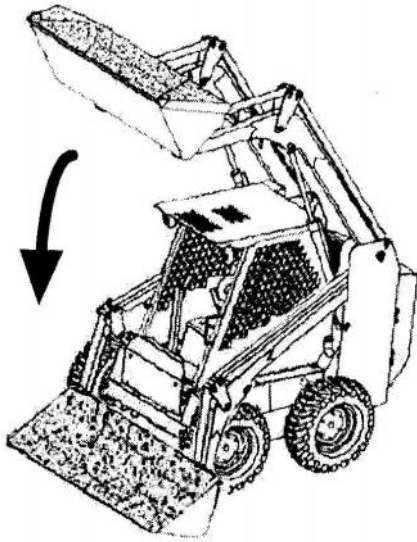

Fig 23 Wrong

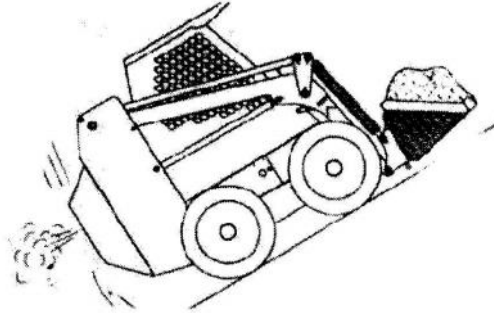

Fig 24 Wrong

Be alert for hazards. Know where you are at all times. Watch for branches ,cables or doorways

Use caution when working along docks, runways, banks, slopes. Keep away from the edges of drop offs

Use caution when working beneath suspenders

Warning: never undercut a high bank (Fig 26)

Extreme caution should be used when working along the top of banks or slopes keep away from the edge

Warning: never operate the machine too close to the suspenders or the edge of valley. collapse or coast could cause serve injury or death

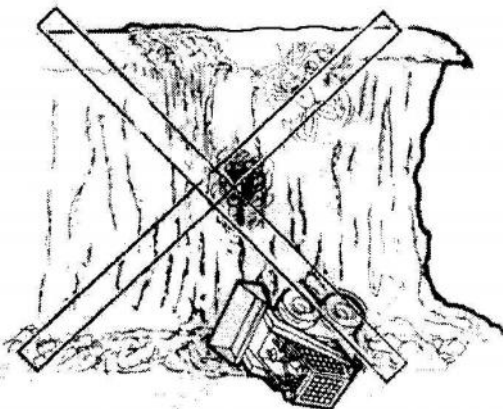

Fig 25 Wrong

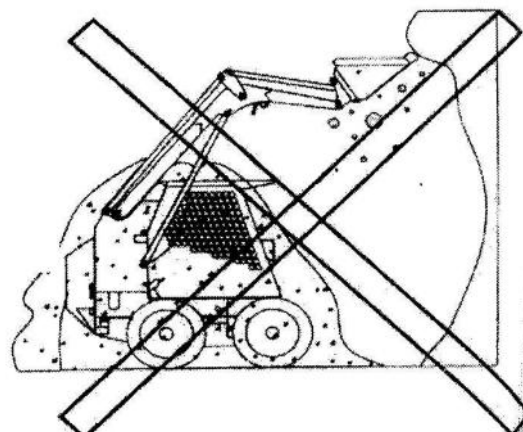

Fig 26 Wrong

Use caution when the loader is backfilling

Do not get too close to the trench wall. The combined weight of your equipment and the load could cause the trench wall to give way (Fig 27).Before backfilling,read the manufacturer's operator manual

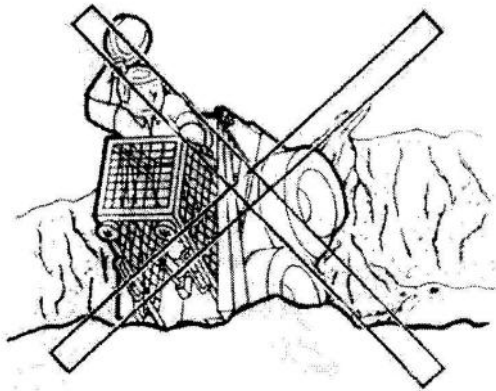

Fig 27 Wrong

When working under hazardous conditions, another person must work with you, but he can not get too close to your loader. When handling special material such as rocks, gas cylinders, barrels etc, you must be carefully. Lifting too high or rolling bucket too far back could result in these materials falling into the operator's cab. (Fig 28). Special enclosures must be used with the attachment. You can check from your dealer.

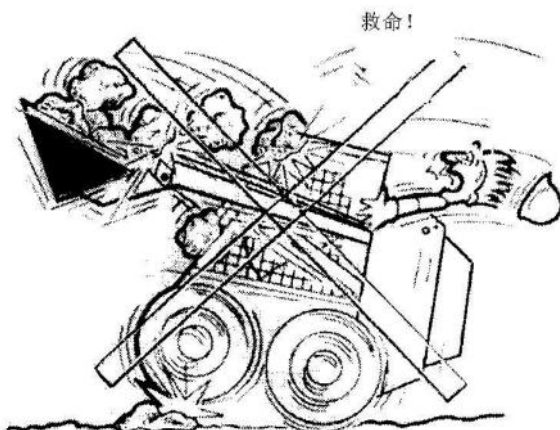

Fig 28 Wrong

Operation in flammable/explosive atmospheres

Ventilation is very important when loader is used in a closed space. Exhaust from loader have deadly components which are odorless and invisible.

Warning: Exhaust from diesel engine is very harmful to people (Fig 29)

Only use "approved" skid steer loader when operating in areas with flammable or explosive atmospheres.

The normal loader or loader with spark protection can not work under such condition because it will result in fires or explosions which could cause serious injury or death. (Fig 30)

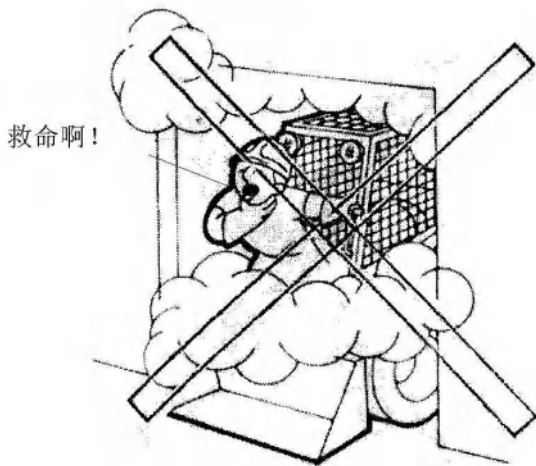

Fig 29 Wrong

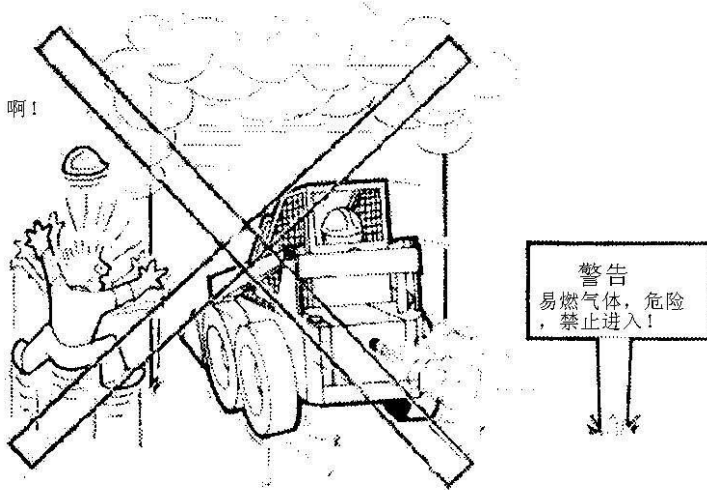

Fig 30 Wrong

Caution of the obstacle

Adjust your speed according to the working conditions

Be cautious of the obstacle,go around rocks ,stub,ditches,or tracks of railway(Fig 31).if it can't go around the obstacle,pls reduce the speed and lift the bucket or attachments to go through with some angle. If the loader is used to scrape the road surface pls inspect the concealed obstacle to avoid the hit. when passing the railway,first stop and take off the earphone,if it is necessary first hear and look whether the train comes.

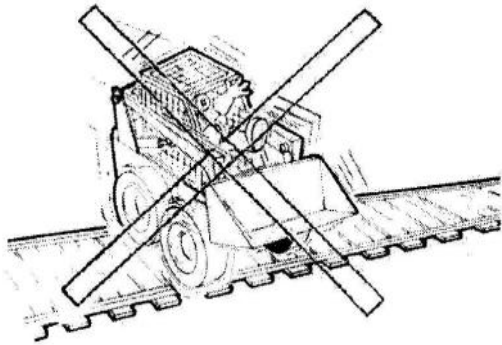

Fig 31 Wrong

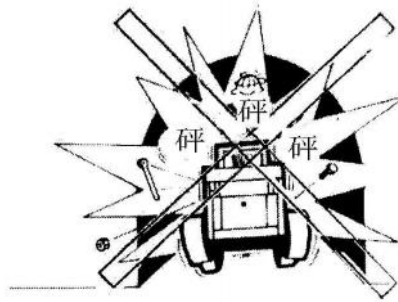

Fig 32 Wrong

Keep the loader under the control all the time, while entering the channel or coal warehouse be cautious of the traffic condition and obstacle (Fig 32).

When the visibility is down to some degree, pls reduce the speed the minimum.

Load and unload the loader safely

When loading and unloading the loader the safety belt should be tightened. please comply with the advice of manufacturer and procedure of loading and unloading.

Several procedures listed are suitable for all kind of engineering machinery:

1. Load and unloaded on the level field
2. the transportation facility should be fixed to avoid the moving
3. using the sufficient size, strong, gradient and high suitable slope
4. keep the clean of the trailer, don't have the mud, oil, ice or other things leading to the slide
5. reverse the loader to the transportation facility through the slope when loading, (drive the loader directly when unloading the loader)
6. fix the loader with chain and wood to increase the security of transportation (Fig 33)

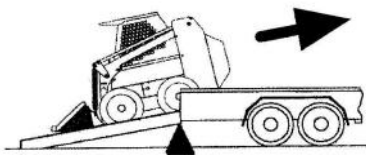

Fig 33 Right

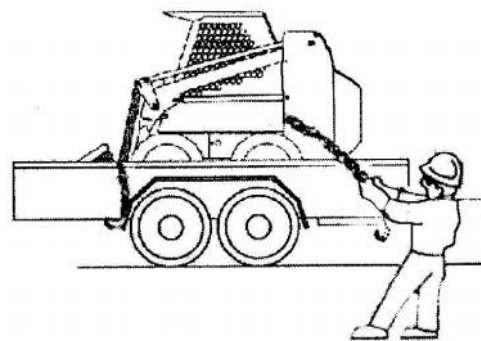

Fig 34 Right

Safety parking

1. Choose the place

Try to choose the level place, if you have to park the loader on the slope, pls park the loader in the right angle, make the operating bar in the middle, lower the bucket to the road surface and block the wheel of the loader. (Fig 35)

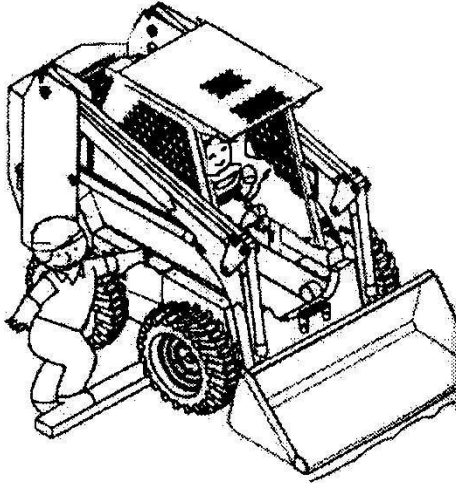

Fig 35 Right

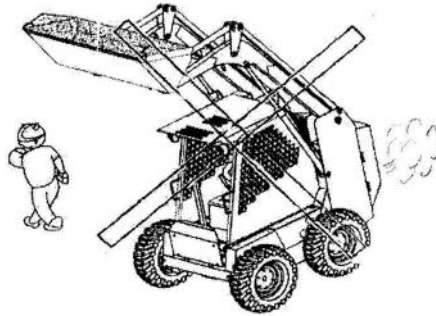

Fig 36 Wrong

WARNING: Don't leave the loader when it is running or the lifting arm is up (Fig 36)

Locking

Locking procedure is detailedly listed on the operation manual, usually include below procedures:

1. stop machine
2. lower the bucket to the road surface
3. make the operation equipment in the middle
4. run the engine at empty gear position to cool in short time
5. stopping
6. lift the operation bar (if equipped)
7. inspect if the operation equipment fixed in the middle
8. loosen the safety belt
9. take out key (Fig 37)
10. shut off the controlling electric switch (if equipped)
11. When leaving the loader, hold the handle and make three point of body contact with the machine, don't jump off the machine (Fig 38)
12. when leaving the loader be cautious of the sliding of the handle
13. if parking on the slope Please block the wheel

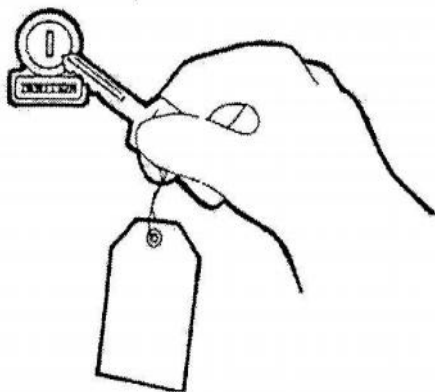

Fig 37 Wrong



Fig 38 Wrong

Safety maintenance and safeguard

Regular procedures

Don't operate the loader unless you are allowed or qualified to do this

If you are authorized to maintain the machine Please read the operation manual,study the guide of operation,check the lubrication meter,check the all the guiding information.the wrong operation will lead to the accident.Operator must grasp the skills and be familiar with the feature of the machine, moreover operators maintain the machine with the proper tools or equipments(Fig39).after the maintenance of the loader the mark of warning such as "operation forbidden" should be paste on the starting switch or operation bar.if not stating the machine, take out the starting key.

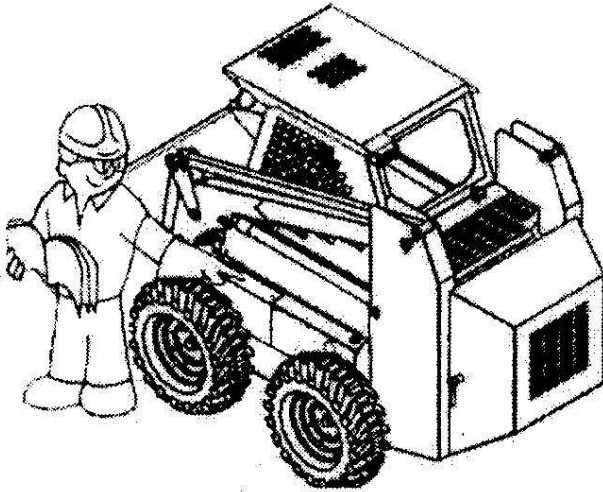

Fig 39 Right

Prepare the working area

Choose the clear and flat working area,ensure there is sufficient space.Check and clean the working area make sure the light is enough and are aeration.Wipe out the oil and water of the surface of working area, ensure the maintenance is going on the clean surface of the work area. (Fig 40)



Fig 40 Wrong



Fig 41 Wrong

Preparation for the maintenance worker

1. wear the protection dress required by the work(Fig 41)
2. workers must wear the rubber apron and gloves when contacting the caustic material and wear the glove and protecting shoes when deal with wood of the sharp metals.

Safety maintenance

Self preparation

When the machine working or using the tools,you must wear the protection veil to avoid the eyes hurt by the welding,high pressure oil,or the metal scrap(Fig42) .

Wear the protection veil when taking down the implement of the spring or contacting the liquid of battery.wear the helmet when welding or cutting.

Please refer the operation manual or inquiry the manufacturer if need weld on the machine.

WARNING:All the rotating parts must keep clean,packing material or things tangling on it will lead to the serious injury or death.The operator's hand and clothes should be far from the rotating part.Tie,loose sleeve,ear ring,long hair and other object which is easy to be tangled to the rotating part will lead to accident,don't put the small stuff which be easy fall to the machine in the pocket (Fig 44).Please ask other to cooperate when moving the heavy tools or spare parts.



Fig 42 Wrong

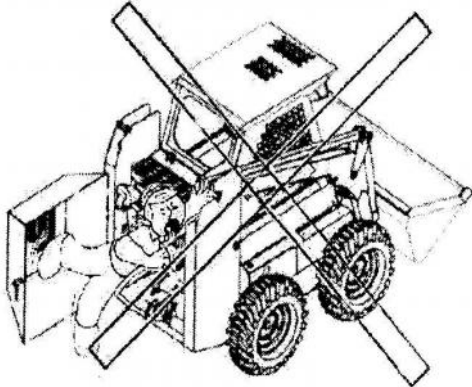

Fig 43 Wrong

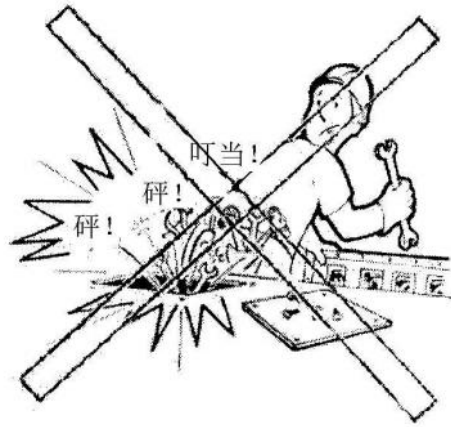

Fig 44 Wrong

Safety maintenance the machine

Preparation

WARNING: Operate the loader unless you sit on the driving seat, otherwise the machine may be out of control and lead to the serious injury or death.

Move the machine on the flat road, then stop, reduce all the pressure of the hydraulic equipment. Fix the lifting arm or lock attachments or lower them to the ground. Keep the the operating level in the lock position.

WARNING: When the engine is running, do not work on the loader unless the items which are listed in the operation manual

WARNING: Don't operate the machine when the ventilation is poor, the gas exhausted by the machine will lead to danger, if it is necessary to work in the sealed room, pls extend the muffler to make the exhausted gas out the seal room or open the door to make the fresh air in.

If the running machine is needed to adjust, it require two worker regularly, one is in the driving cabin another one do the work. (Fig 45).

Blocking the wheels: make the operating level in the middle, cut off the electric and take out the

ignition key.

Open the engine room cover,wipe out the surplus grease and lubrication oil.

Don't keep the engine room cover open when nobody takes charge the machine,if the cover open let the surrounding people far away from the machine.

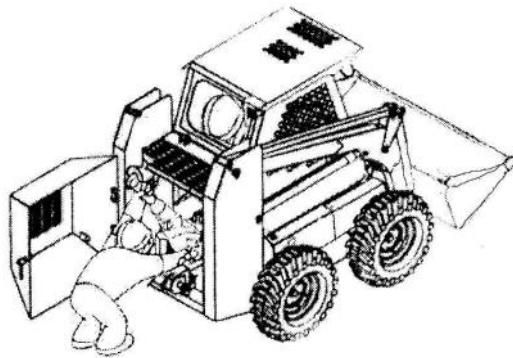

Fig 45 Right

Make sure all the protection devices,instruments, safety warning signs are back to the position the manufacturer stipulate

Using the jack and crane carefully

If you have to work under the hoisting equipment you must use the wood,jack or other rigidity,stable sustainer to sustain it solidly. Make sure the sustainers have the enough force.

WARNING:DON'T USE THE CEMENT AS THE SUSTAINER,IT WILL COLLAPSE ALTHOUGH THE PRESSURE IS LIGHT. (Fig 46)



Fig 46 Wrong

Avoid the injury of electric system

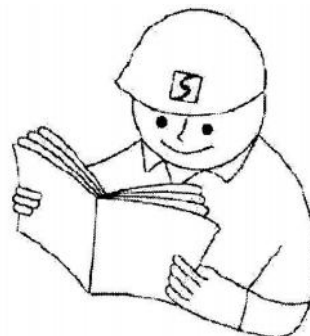

Fig 47 Right

Before deal with the electric system, shut off the connection with the battery, remove the wire, reconnecting the wire when the battery is connected again

Don't deal with the fault of the electric system unless you are familiar with it (Fig 47)

Note the pressure of flowing liquid

The hydraulic system has the pressure no matter the engine running or not

Install the lifting arm restraint device(the head of the cylinder rod) or hydraulic system protection device

No fire or flame are allowed close to the hydraulic system,if there is leakage of the hydraulic oil, it must be wiped out at once.

WARNING:diesel or hydraulic oil may penetrate the skin or eyes under the pressure,it may lead to serious injury,blind,or death.the leakage under the pressure maybe not obvious,you may test it by the paper plate or wood,never test it by naked hand.Wear the protecting glasses to protect the eyes,if the liquid splash on the skin,ask the professional doctor to treat it(Fig48).

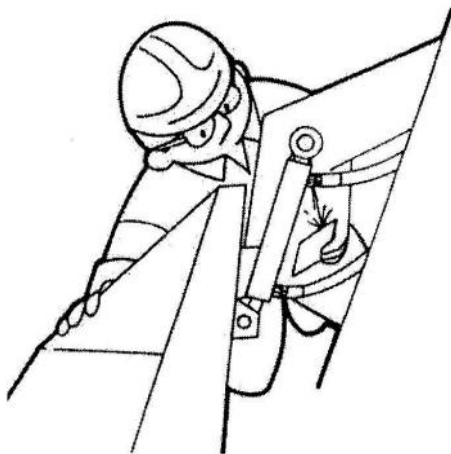

Fig 48 Right

Note the cooling system

WARNING:When the engine becomes hot the cooling system will create the some pressure, so shut off the engine to let the cooling system cool before open the radiator cover(Fig 49), open the radiator cover after the cooling water become normal.

When the cooling system has the water tank that water can overflow, you can check the cooling water without removing the radiator cover.

Avoid the fire or explosion

When add the fuel to the loader,first stop the engine,shut off the electric system.when adding fuel to the hot engine,it must be specially careful,put the filler contact with the neck of the filter to avoid the spark.

WARNING:Don't smoke when adding the fuel,it will lead to explosive if using the fire to fume

the fuel tank, don't cut or weld the fuel pipe, fuel tank or other fuel containers. (Fig 50)

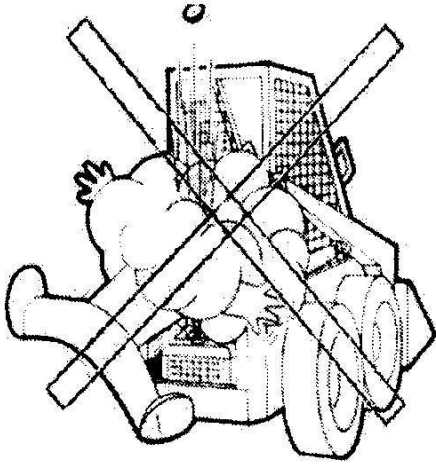

Fig 49 Wrong



Fig 50 Wrong

The right way to clean the fuel tank is by the dissoluble or dry chemical, it must be done on the condition of aeration.

Take out the garbage or fragment to make sure there is no remains or other flammable stuff. Check the diesel, oil and hydraulic oil leakage or not, if there is such leakage it must be repaired by operating, meanwhile clean the surface of the machine. Aether is flammable, never smoke when using the aether, pls comply with the rule of the manufacturer manual to operate, if finding the machine installed the hot line ignition plug or other preheat device, don't use the aether.

When cleaning the part, choose the inflammable impregnant, don't use the gasoline, diesel, or other flammable liquid.

Be acquainted with the location of the fire extinguisher
Check the preparation of fire extinguisher and fire warning detector

Avoid the hurt of battery

WARNING: Vitriol in the acid battery can hurt the eyes or skin, so wear the veil to protect the eye, if the vitriol enter the eyes, rinse the eyes with clean water at once and cure it with proper medicine. Wear the rubber glove and shield to protect the skin. If the skin is splashed the vitriol rinse the skin with plenty of water.

Acid battery can produce flammable gas, so keep away from the sparks and flames (Fig 51)

Check the electrolyte of battery with torch, stop the engine when checking (Fig 52)

If the battery freezes don't charge the battery or start the engine by pushing. The right way is to heat the temperature up to 15°C, then operate it.

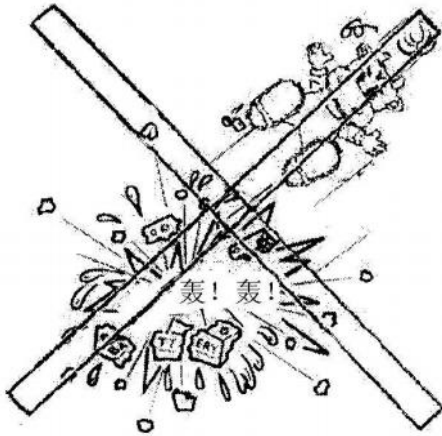

Fig 51 Wrong



Fig 52 Right

Maintenance of tyre

Warning: The abruptly separation of tyre or hub will cause seriously injury. Please follow the suggestion of the producer or consult the supplier of tyre.

To replace the truck's tyre or high-speed tyre need special tools and procedure, in order to be safety, must operate in the correct way and operate step by step according to the servicing manual. At the same time, To replace the tyre, It is better charged by the Tyre servicing compay. Keep the tyre suitable pressure and do not charge the tyre more than suggested pressure. Withdraw the load on the machine when charging. Pls refer to the stipulation from the manufacturer.

Check the tyre and hub everyday, Do not work when the tyre is low pressure or the hub damaged or lack of bolt or nut. Pls tighten the nut of the wheel according to the manufacturer's request.

It is normal that the pressure of the tyre increase during working. Do not deflate. Please keep distance when charging the tyre. Stand at the behind of the tyre when adjusting the pressure of the tyre. (Fig. 53)

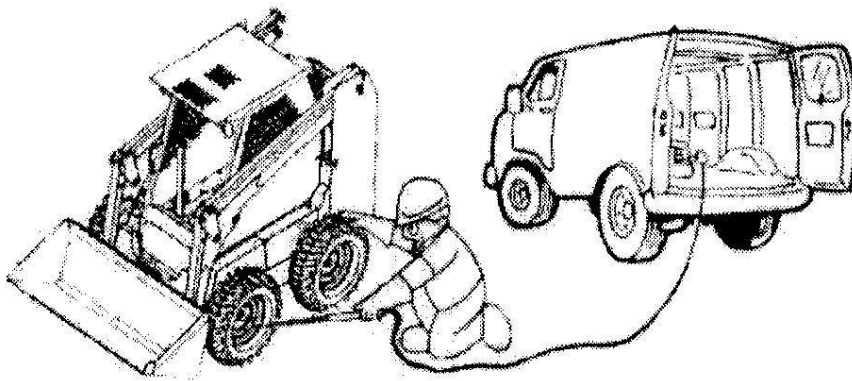

Fig53 correct

Maintenance of tyre:

Do not use flammable gas or ethanol nozzle system charging the tyre.

Do not cut or weld the hub when the hub fixing the charged tyre. It can cause crack of the tyre.

Repair of tyre:

To repair the tyre need a salted technician with safty equipment in correct prodedure.. Check the dismension of the new hub before mounting

Tighten all the bolts and buts and reach the stipulated torque of the manufacturer.

Fix all the guards and covers, repair or replace the damaged parts after maintenance. Adjust the pressure system according to the manufacturer's advice.

Starting the machine to check the leakage.Operate all the control system to make sure the machine work properly. If it is necessary, test the loader on the road. Stop the engine, check the machine (Any loosing gob pin,gasket,locknut etc) (Fig.54).

Check all the oil level before operation.

All the parts shoud be checked whether it is worn out or damaged. Excessively worn or damaged may cause injury. Must replace the bad parts in time.

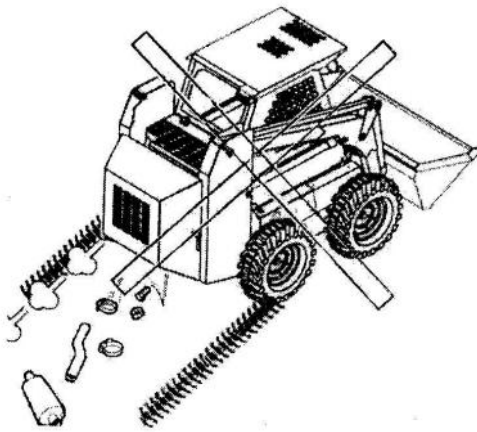

Fig54 error

Now test the knowledge you grasped

You have looked through the safty manual, do you understand the follows:

- your safty issue.
- The manufacturer's manual book of your machine.
- Correct clothes and personal safety facility.
- The control of the machine and warning signs,and safety facility.
- How to check, install, and start your machine.
- How to check your machine whether it is work properly
- Your working site and any possible risk.
- The proper operating procedure
- The maximum capacity of the bucket and other attachments
- The correct way of parking, shutdown and dismounting procedures
- The correct maintenance procedure
- The correct way of loading unloading and transporting
- You can not operate your machine under what kind of conditions
- Other local rules that can affect your use of the machine.

Tag

Well, you have studied the safety manual of the skid steering loader, The manual included all the possible risks during operation. But only the correct judgement of working condition and environment, can help you deal with the breaking out affairs properly. Therefore, Our goal is help you to have a good, criterion working habit. To be a excellent loader driver.

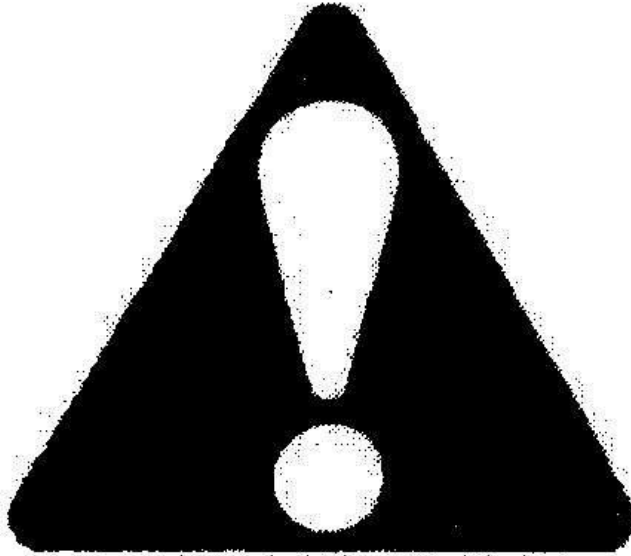

Remember: Safety first! This is your duty and obligation.