



Village of Bayside
9075 N Regent Road
Board of Trustees Meeting
May 20, 2021
Remote Teleconferencing, 6:00pm

**BOARD OF TRUSTEES
AGENDA**

PLEASE TAKE NOTE: Due to the COVID-19 Pandemic, the Village Board will be meeting via remote teleconferencing at the above noted time and date, at which the following items of business will be discussed and possibly acted upon.

I. CALL TO ORDER AND ROLL CALL

II. PLEDGE OF ALLEGIANCE

III. CITIZENS AND DELEGATIONS

Open to any citizen who wishes to speak on items not on the agenda. Please note there may be limited discussion on the information received, however, no action will be taken. Please state your name and address for the record.

IV. CONSENT AGENDA

Upon request of any Trustee, any item may be removed from the Consent Agenda for separate consideration.

A. Approval of:

1. Board of Trustees meeting minutes, April 15, 2021.
2. Summary of Claims for April 9, 2021 through May 7, 2021 in the amount of \$548,343.21.
3. April 2021 Financial Statement.
4. April 2021 Community Impact Report.
5. Raze/repair order 550 E Glencoe Place.

V. BUSINESS AGENDA

A. COMMITTEE AND COMMISSION REPORTS

1. Public Safety Committee

- a. Discussion/action on April 2021 Communication Center Report.
- b. Discussion/introduction of Brittany Jelenc, Deputy Communications Director (Bayside Communications Center).
- c. Discussion/action on April 2021 Police Department Report.
- d. Discussion/action on myBlue Neighbor Mediation Program partnership with Mediation and Restorative Justice Center, A Program of Wisconsin Community Services, Inc.

2. Public Works Committee

- a. Discussion/action on April 2021 Department of Public Works Report.
- b. Discussion/update on 2021 capital projects.

3. Finance and Administration Committee

- a. Discussion/action on April 2021 Administrative Services Report.
- b. Discussion/action on Resolution 21-____, A Resolution to Rescind Declaration of Public Health Emergency in Response to the COVID-19, Coronavirus.
- c. Discussion/action on Resolution 21____, a Resolution to Authorize the Sale and Consumption of Fermented Malt Beverages in Village Parks Under Section 125.06(6) Wis. Stats.
- d. Discussion/action on purchase of playground equipment from MidStates Recreation and Boland Recreation LLC. for Ellsworth Park.
- e. Discussion/action on scheduling Independence Day Parade, Village Picnic, Bayside Five and Wine, and Movie in the Park.

4. Intergovernmental Cooperation Council

5. Board of Zoning Appeals

- a. Discussion/action on the request for a special exception by Matthew and Claire Evans, for the property located at 309 E Fairy Chasm Road, to construct an 8'x10' shed that will encroach into the rear yard setback, contrary to Section 125-91(b)(5).

6. Architectural Review Committee

7. Plan Commission

- a. Discussion/action on the request for a Conditional Use Permit for R Design at 333 W Brown Deer Road Suite #10 for an interior design office/studio.

8. Library Board

- a. Discussion/action on the April 2021 Library Report.

9. North Shore Fire Department

10. Community Development Authority

VI. VILLAGE PRESIDENT'S REPORT

- A. Discussion/action on appointment to Village committees.

VII. VILLAGE MANAGER'S REPORT

VIII. VILLAGE ATTORNEY'S REPORT

IX. MISCELLANEOUS BUSINESS BY THE TRUSTEES AS MAY PROPERLY BE BROUGHT BEFORE THE BOARD

X. ADJOURNMENT

Lynn Galyardt, Administrative Services Director

The Board of Trustees will utilize Zoom videoconferencing software for this meeting. To join the Zoom meeting using a computer or tablet, visit <https://us02web.zoom.us/j/88307088242?pwd=Y3NXak9XbDh5ZkdqVIZvUkpRajA3dz09>
Meeting ID: 883 0708 8242; Passcode: 68474, 1-312-626-6799. Upon reasonable notice, efforts will be made to accommodate the needs of disabled individuals through appropriate aids and services.

Contact Village Hall at 414-206-3915. It is possible that members of and possibly a quorum of members of other Boards, Commissions, or Committees of the Village may be in attendance in the above stated meeting to gather information; no action will be taken by any other Boards, Commissions, or Committees of the Village except by the Board, Commission, or Committee noticed above. Agendas and minutes are available on the Village website (www.baysidewi.gov)



Village of Bayside
9075 N Regent Road
Board of Trustees Meeting
May 20, 2021
Remote Teleconferencing, 6:00pm

**BOARD OF TRUSTEES
SUPPLEMENTAL AGENDA NOTES**

- I. **CALL TO ORDER AND ROLL CALL**
- II. **PLEDGE OF ALLEGIANCE**
- III. **CITIZENS AND DELEGATIONS**
- IV. **CONSENT AGENDA**

A. Approval of:

- 1. **Board of Trustees meeting minutes, April 15, 2021.**
- 2. **Summary of Claims for April 9, 2021 through May 7, 2021 in the amount of \$548,343.21.**
- 3. **April 2021 Financial Statement.**

Included in the packet is the April 2021 Financial Statement. Revenues and expenditures are on track year-to-date. **Approval is recommended.**

- 4. **April 2021 Community Impact Report.**

Included in the packet is the April 2021 Community Impact Report. Of significant note, social media reach has increased 12% year-to-date due to the new Twitter scheduling features provided through Canva, our content creating program. **Approval is recommended.**

- 5. **Raze/repair order 550 E Glencoe Place.**

The property at 550 E Glencoe experienced a significant fire in January of 2021. SAFEBuilt, Inc., the Village's building inspector has determined that the structure is out of repair and consequently dangerous, unsafe, and otherwise unfit for use or occupation. The owner of this property has 30 days from service of this order to repair or raze the structure. The Board has previously approved the report on this property. This is the formal raze order that would be served to the property owner. **Approval is recommended.**

V. BUSINESS AGENDA

A. COMMITTEE AND COMMISSION REPORTS

- 1. **Public Safety Committee**
 - a. **Discussion/action on April 2021 Communication Center Report.**

Included in the packet is the April 2021, Communication Center Report. Of significant note, the Center has been conducting interviews to bring on three new dispatchers. Dispatch calls are up 7% year-to-date. **Approval is recommended.**

b. Discussion/introduction of Brittany Jelenc, Deputy Communications Director (Bayside Communications Center).

Brittany Jelenc began working with the Village on April 5, 2021 as Deputy Communications Director for the Bayside Communications Center. She brings an extensive background in dispatch and public safety services to the Center. Welcome to the team, Brittany!

c. Discussion/action on April 2021 Police Department Report.

Included in the packet is the April 2021 Police Department Report. Of significant note, the Department received \$5,000 for high visibility speed enforcement. Traffic stops have increased 16% year-to-date. **Approval is recommended.**

d. Discussion/action on myBlue Neighbor Mediation Program partnership with Mediation and Restorative Justice Center, A Program of Wisconsin Community Services, Inc.

A portion of the myBlue Program is to mediate concerns amongst residents. Issues can go beyond the capabilities of the Sector Officers to come to a resolution. Chief Larsson has worked with Mediation and Restorative Justice Center to enter an arrangement for mediation services.

Part of the mission to create a safe and friendly environment is to offer mediation to solve ongoing issues. The attached program brochure provides an overview of the program.

The Bayside mediation service is a process that assists people in resolving conflicts or disputes. The mediation session offers people the opportunity to create their own mutually agreeable solutions with the assistance of a trained, impartial third-party – a mediator. The mediator does not make decisions for the people involved or determine who is right or wrong. Mediation is not a court hearing or a counseling session.

Mediation sessions are casual yet structured to help clarify the issues and move towards agreement. Parties are given the opportunity to speak without interruption. If an agreement is reached, it may be signed by the parties. Before participating in a mediation session, the parties should think about possible solutions to the problem. **Approval is recommended.**

2. Public Works Committee

a. Discussion/action on April 2021 Department of Public Works Report.

Included in the packet is the April 2021 Department of Public Works Report. Of significant note, the first Clean Up Day was hosted since Fall of 2019 yielding 336 residents who participated. **Approval is recommended.**

b. Discussion/update on 2021 capital projects.

The lift stations at Hermitage Rd. and Bay Point Rd. are primarily finished with construction. The internal controls at the Bay Point lift station are completed and fully functioning. The Hermitage lift station should be completed in the following weeks. Landscaping and site work would be completed in late spring/early summer.

We anticipated ditching and stormwater work for the 2021 Road Project is scheduled to begin in June. Road paving will begin in late August/early September. The stormwater management pre-construction meeting will be held in the near future.

Arch Electric completed the installation of the solar panels on the DPW building. The project was completed in 3 weeks. The project will be commissioned and finalized during the week of May 17.

3. Finance and Administration Committee

a. Discussion/action on April 2021 Administrative Services Report.

Included in the packet is the April 2021 Administrative Services Report. Of significant note, Accurate Appraisal completed the 2021 assessment data for the Village. Notices are anticipated to be mailed to residents with a change in their assessment on May 20. **Approval is recommended.**

b. Discussion/action on Resolution 21-____, A Resolution to Rescind Declaration of Public Health Emergency in Response to the COVID-19, Coronavirus.

The Village first declared a Public Health Emergency in March, 2020. The declaration was extended indefinitely in August, 2020. Based on local vaccination rates, case load, and other factors, the proposed resolution establishes a June 1 date to rescind the order. Village operations have resumed a sense of normalcy. This resolution also modifies mask requirements in Village facilities, where they will now be recommended and encouraged, but not required. Village staff will continue to be required to wear masks when engaging with the public at front counters, traffic stops, etc. **Approval is recommended.**

c. Discussion/action on Resolution 21____, a Resolution to Authorize the Sale and Consumption of Fermented Malt Beverages in Village Parks Under Section 125.06(6) Wis. Stats.

The resolution permits the operation of outdoor beer gardens for 2021 with 1840 Brewing as well as at the Village Picnic, Five and Wine, and Movie in the Park events. **Approval is recommended.**

d. Discussion/action on purchase of playground equipment from MidStates Recreation and Boland Recreation LLC. for Ellsworth Park.

The Village has experienced a significant increase in park usage in the past year since the onset of the COVID-19 Pandemic. Due to the changing utilization of equipment, community desire for additional amenities that allow for social distancing, and age of existing equipment, Village staff has extensively researched new free-standing equipment for Ellsworth Park. The Village has received quotes from multiple vendors and taken part in a modified bidding process to examine various structures and alternatives for the equipment. The two attached quotes from Boland Recreation and MidStates Recreation are recommended for free-standing play structures and adult exercise equipment. The Village has received discounts from both vendors. The installation would be performed through a public-private partnership with DPW and volunteers in a community build. Due to the pandemic, there are significant lead times on equipment delivery. Anticipated installation is currently planned for September. **Approval is recommended.**

e. Discussion/action on scheduling Independence Day Parade, Village Picnic, Bayside Five and Wine, and Movie in the Park.

The Independence Day Parade was modified in 2020 and was conducted as a car parade. Given the conditions of the COVID-19 pandemic at that time, the Village received positive feedback about the driving parade. Most municipalities who have chosen to hold an Independence Day parade in 2021 have planned to expand their route to allow for greater distancing. Due to the area restrictions in the Village, we suggest continuing the car parade in 2021 and returning to the normal parade format in 2022.

The Village has begun planning a modified event for the Village Picnic which is scheduled to take place on September 25. The Picnic will be held from 2pm to 7pm with food being served from 2pm to 6pm and drinks from 2pm to 9pm. The Movie in the Park will become the Movie on the Sled Hill and will begin at 7:15pm. Lawn games and other events have also been planned to take place throughout the day. Staff has run into logistical and vendor issues due to availability. Staff is seeking approval of the above timelines for events to allow for more in-depth planning.

The Five and Wine, previously known as the 5K and 2-mile walk, will start at 4pm in front of Village Hall and end in front of Village Hall. Routes are still being determined as there is a conflict with the Schlitz Audubon Nature Center and we cannot utilize their property for the route. **Approval is recommended.**

4. **Intergovernmental Cooperation Council** – No report.
5. **Board of Zoning Appeals**
 - a. **Discussion/action on the request for a special exception by Matthew and Claire Evans, for the property located at 309 E Fairy Chasm Road, to construct an 8'x10' shed that will encroach into the rear yard setback, contrary to Section 125-91(b)(5).**

The Board of Zoning Appeals unanimously recommended approval of the project on May 5, 2021. **Approval is recommended.**

6. **Architectural Review Committee** – No report.
7. **Plan Commission**
 - a. **Discussion/action on the request for a Conditional Use Permit for R Design at 333 W Brown Deer Road Suite #10 for an interior design office/studio.**

The Plan Commission unanimously recommended approval of the project on May 4, 2021. **Approval is recommended.**

8. **Library Board**
 - a. **Discussion/action on the April 2021 Library Report.**

Included in the packet is the April 2021 Library Report. **Approval is recommended.**

9. **North Shore Fire Department** – No report.
10. **Community Development Authority** – No report.

VI. VILLAGE PRESIDENT'S REPORT

A. Discussion/action on appointment to Village committees.

VII. VILLAGE MANAGER'S REPORT

VIII. VILLAGE ATTORNEY'S REPORT

IX. MISCELLANEOUS BUSINESS BY THE TRUSTEES AS MAY PROPERLY BE BROUGHT BEFORE THE BOARD

X. ADJOURNMENT



I. CALL TO ORDER AND ROLL CALL

President Walny called the meeting to order at 6:00pm via remote teleconferencing.

ROLL CALL

President: Eido Walny
Trustees: Mike Barth
Darren Fisher
Joshua Roling
Bob Rudman
Margaret Zitzer

Also Present: Village Manager Andy Pederson
Village Attorney Chris Jaekels
Administrative Services Director Lynn Galyardt
Public Works Operations Superintendent Shane Albers
Assistant to the Village Manager Leah Hofer
Communications Center Director Liane Scharnott
There was one person in the audience.

II. PLEDGE OF ALLEGIANCE

III. CITIZENS AND DELEGATIONS

A. Presentation from Kim Sebastian from Wisconsin DNR regarding the Village of Bayside Tree City USA award.

Ms. Sebastian presented the Village with its thirteenth consecutive Tree City USA award and acknowledged the Village's efforts in planning and protecting trees in the community. By doing this, the Village has shown its commitment to maintaining a high quality of life for residents. The Village met all four standards of Tree City USA, joining 197 other communities who have also received the award.

IV. CONSENT AGENDA

Upon request of any Trustee, any item may be removed from the Consent Agenda for separate consideration.

A. Approval of:

1. Board of Trustees meeting minutes, March 18, 2021.
2. Summary of Claims for March 13, 2021 through April 8, 2021 in the amount of \$115,650.47.
3. Proclamation Recognizing April 11-17, 2021 as National Public Safety Telecommunications Week.
4. Proclamation Recognizing May 2-8, 2021 as Municipal Clerks Week.
5. Proclamation Recognizing May 9-15, 2021 as National Police Week.
6. Proclamation Recognizing May 16-22, 2021 as National Public Works Week.
7. Proclamation Recognizing May 16-22, 2021 as Emergency Medical Services Week.
8. Resolution 21-___, A Resolution of Appreciation for North Shore Health

- Department Director Ann Christiansen.**
- 9. March 2021 Financial Statement.**
- 10. March 2021 Community Impact Report.**
- 11. Municipal Maintenance Easement for 845 Glenbrook Rd, 857 Glenbrook Rd, and 700 Laramie Ln.**

Motion by Trustee Zitzer, seconded by Trustee Roling, to approve Board of Trustees meeting minutes, March 18, 2021; Summary of Claims for March 13, 2021 through April 8, 2021 in the amount of \$115,650.47; Proclamation Recognizing April 11-17, 2021 as National Public Safety Telecommunications Week; Proclamation Recognizing May 2-8, 2021 as Municipal Clerks Week; Proclamation Recognizing May 9-15, 2021 as National Police Week; Proclamation Recognizing May 16-22, 2021 as National Public Works Week; Proclamation Recognizing May 16-22, 2021 as Emergency Medical Services Week; Resolution 21-18, A Resolution of Appreciation for North Shore Health Department Director Ann Christiansen; March 2021 Financial Statement; March 2021 Community Impact Report; and Municipal Maintenance Easement for 845 Glenbrook Rd, 857 Glenbrook Rd, and 700 Laramie Ln. Motion carried unanimously.

V. BUSINESS AGENDA

A. COMMITTEE AND COMMISSION REPORTS

1. Finance and Administration Committee

a. Discussion/acceptance of Government Finance Officers Association Certificate of Achievement for Excellence in Financial Reporting.

Trustee Barth stated this is the tenth year the Village has received the Government Finance Officers Association Certificate of Achievement for Excellence in Financial Reporting. The Government Finance Officers Association Certificate of Achievement for Excellence in Financial Reporting recognizes all the work Village staff has done regarding the reporting and tracking of Village finances.

Manager Pederson stated that this is the highest level of financial reporting excellence that a community can receive.

Motion by Trustee Zitzer, seconded by Trustee Roling, to accept Government Finance Officers Association Certificate of Achievement for Excellence in Financial Reporting. Motion carried unanimously.

b. Discussion/action on March 2021 Administrative Services Report.

Director Galyardt provided an overview of the March 2021 Administrative Services Report noting the Village received the lottery and gaming credit, completed the Cities and Villages Mutual Insurance Company worker's comp audit, collected taxes, and mailed 798 absentee ballots as of March 31.

Motion by Trustee Fisher, seconded by Trustee Roling, to the accept March 2021 Administrative Services Report. Motion carried unanimously.

c. Discussion/action on Resolution 21-____, A Resolution to amend the 2021 Budget to reflect changes in revenues and expenditures.

Trustee Barth stated the resolution reflects the expenditures for the Next Gen 911 project.

Motion by Trustee Zitzer, seconded by Trustee Fisher, to approve Resolution 21-19, A Resolution to amend the 2021 Budget to reflect changes in revenues and expenditures. Motion carried unanimously by roll call vote.

d. Discussion/action on Ordinance 21-____, An Ordinance to Repeal and Recreate Section 104-4(n) and to Create Section 104-4(o) of the Municipal Code with Regard to Solar Energy Systems.

Trustee Barth stated the ordinance relates to the legal requirements and the limits as to what the Village can do regarding solar.

Motion by Trustee Roling, seconded by Trustee Fisher, to approve Ordinance 21-722, An Ordinance to Repeal and Recreate Section 104-4(n) and to Create Section 104-4(o) of the Municipal Code with Regard to Solar Energy Systems. Motion carried unanimously by roll call vote.

e. Discussion/action on We Energies LED Street Light Conversion.

Trustee Barth stated that there will be a 23-month payback by converting the streetlights to LEDs.

Motion by Trustee Fisher, seconded by Trustee Roling, to approve the We Energies LED Street Light Conversion. Motion carried unanimously.

2. Public Works Committee

a. Discussion/action on March 2021 Department of Public Works Report.

Operations Superintendent Albers provided an overview of the March 2021 Department of Public Works Report noting 96 trees had been removed, the launch of the first ever Salt Take Back program, and a trial run for the salt brine pilot program, which proved to be successful.

Motion by Trustee Zitzer, seconded by Trustee Fisher, to accept the March 2021 Department of Public Works Report. Motion carried unanimously.

b. Discussion/action on agreement with Clark Dietz, Inc. to complete the WDNR Urban Nonpoint Source Planning grant and update the Stormwater Management Plan.

Manager Pederson stated the Village last updated the Stormwater Management Plan in 2009. The Village has solicited quotes from multiple firms and interviewed them and are recommending Clark Dietz. The plan will consist of computer modeling and determining whether the Village meets pollutant reduction goals by the DNR and EPA. The proposal is at \$51,300, which is lower than the \$80,000 the Village was expecting for the project. The Village is applying for a grant and will hear back by October. Most of the work will be done in 2022, with the Board adopting the plan in early 2023.

Motion by Trustee Barth, seconded by Trustee Zitzer, to approve the agreement with Clark Dietz, Inc. to complete the WDNR Urban Nonpoint Source Planning grant and update the Stormwater Management Plan. Motion carried unanimously.

c. Discussion/action on Resolution 21-____, A Governmental Responsibility Resolution for Runoff Management Grants.

Motion by Trustee Barth, seconded by Trustee Zitzer, to approve Resolution 21-20, A Governmental Responsibility Resolution for Runoff Management Grants. Motion carried unanimously by a roll call vote.

d. Discussion/update on 2021 capital projects.

Manager Pederson stated the lift station projects are carrying over into 2021. The lift stations should

be operational within the next couple of weeks.

The public meeting was held for the 2021 road projects, where four residents attended. Residents are currently paying for their culvert replacements. The project is set to begin in early June and go past Labor Day.

Arch Electric has started work on the side of the DPW building and are hoping to begin the installation of solar panels at the end of April or early May.

3. Public Safety Committee

a. Discussion/action on March 2021 Police Department Report.

Manager Pederson provided an overview of the March 2021 Police Department Report noting the union ratified the collective bargaining agreement, the Village is working on identifying why citation revenue is low, and additional enforcement is starting to occur. Chief Larsson is initiating a home inspection program that will do home security assessments for residents and advise them on how to increase the safety around their home.

Motion by Trustee Barth, seconded by Trustee Fisher, to accept the March 2021 Police Department Report. Motion carried unanimously.

b. Discussion/action on March 2021 Communication Center Report.

Director Scharnott provided an overview of the March 2021 Communication Center Report noting that call volume is down, training is being provided for staff, and a smart board was installed in the Communications Center as part of a grant and will be useful in the training program. Brittany Jelenc, the new Deputy Director of Communications started.

Motion by Trustee Fisher, seconded by Trustee Barth, to accept the March 2021 Communication Center Report. Motion carried unanimously.

4. Intergovernmental Cooperation Council – No report.

5. Board of Zoning Appeals – No report.

6. Architectural Review Committee – No report.

7. Plan Commission

a. Discussion/action on Resolution 21-____, A Resolution Recommending the Adoption of a Public Participation Plan for the Update of the Comprehensive Plan.

Manager Pederson stated that the Village has retained Vandewalle and Associates to assist with the update of the Comprehensive Plan. A public meeting will be held on Wednesday, April 21. The Village Board is required to adopt a public participation plan as part of the Comprehensive Plan process, as mandated by the State.

Motion by Trustee Barth, seconded by Trustee Roling, to approve Resolution 21-21, A Resolution Recommending the Adoption of a Public Participation Plan for the Update of the Comprehensive Plan. Motion carried unanimously by a roll call vote.

8. Library Board

a. Discussion/action on the March 2021 Library Report.

Trustee Zitzer provided an overview of the March 2021 Library Report noting a new Library Director will start on April 26. There will be a summer adult program outside of Ellsworth Park and money was received to help the library buy some of their wish list items.

Motion by Trustee Fisher, seconded by Trustee Rudman, to accept the March 2021 Library Report. Motion carried unanimously.

9. North Shore Fire Department-No report.

10. Community Development Authority-No report.

VI. VILLAGE PRESIDENT'S REPORT

A. Discussion/action on Village Committee and Commission appointments.

President Walny noted that there was some shifting of committee and commission appointments.

Motion by Trustee Fisher, seconded by Trustee Barth, to approve Village Committee and Commission appointments. Motion carried unanimously.

VII. VILLAGE MANAGER'S REPORT

Manager Pederson stated the Village was contacted by 1840 Brewing Company in Bay View. They will be hosting a beer garden at Ellsworth Park in May, June, July, and August. The Village will possibly include them in the picnic this upcoming September. They are tentatively scheduled to host a beer garden on May 21, June 5, July 17, August 14, and September 25. In lieu of paying the rental fee, they have agreed to provide beer and live music for the Village picnic.

Manager Pederson provided an overview of the State of the Village. The State of the Village has demographic information and recognitions from the year. This includes highlights of the Village, such as joining the Municipal Court and the myBlue Neighborhood Mediation Program. The Police Department drove a total of 112,881 miles, the Village removed 225 trees, and the Communications Center answered over 100,000 calls. The impacts of COVID-19 are also included, the new strategic plan, and the list of 2021 events.

Saturday, April 17, is the Village's Clean Up Day. The Village is anticipating a high turnout.

VIII. VILLAGE ATTORNEY'S REPORT- No report.

IX. MISCELLANEOUS BUSINESS BY THE TRUSTEES AS MAY PROPERLY BE BROUGHT BEFORE THE BOARD

X. ADJOURNMENT

Motion by Trustee Barth, seconded by Trustee Zitzer, to adjourn the meeting at 6:48 pm. Motion carried unanimously.

Respectfully submitted,

Lynn Galyardt, Administrative Services Director

SUMMARY OF CLAIMS

April 9, 2021 through May 7, 2021

April 9, 2021	\$74,250.42
April 16, 2021	\$269,088.66
April 19, 2021	\$946.61
April 23, 2021	\$1,047.13
April 30, 2021	\$193,480.12
May 7, 2021	\$9,530.27
TOTAL	\$548,343.21

Report Criteria:

Report type: Summary

Check Issue Date	Check Number	Payee	Amount
04/09/2021	36839	CAPSTONE CLASSROOM	163.72
04/09/2021	36840	CLEAN SOURCE LLC	3,600.00
04/09/2021	36841	Five Star Telecom Inc	41,882.33
04/09/2021	36842	GREATAMERICA FINANCIAL SERVIC	107.00
04/09/2021	36843	GUETZKE & ASSOCIATES INC.	165.00
04/09/2021	36844	HUMPHREY SERVICE PARTS INC	1,388.24
04/09/2021	36845	OFFICE COPYING EQUIPMENT LTD	135.10
04/09/2021	36846	PACKERLAND RENT-A-MAT INC.	39.00
04/09/2021	36847	PAYNE & DOLAN	9,195.12
04/09/2021	36848	UNEMPLOYMENT INSURANCE	1,130.98
04/09/2021	36849	UTILITY NETWORK LLC	2,850.00
04/09/2021	36850	WE ENERGIES	13,593.93
Grand Totals:			<u>74,250.42</u>

Report Criteria:
Report type: Summary

Check Issue Date	Check Number	Payee	Amount
04/16/2021	36854	AMAZON/SYNCB	528.83
04/16/2021	36855	BAKER & TAYLOR	7,021.92
04/16/2021	36856	BAKER TILLY VIRCHOW KRAUSE LLP	18,000.00
04/16/2021	36857	BERINGER, MATT	17.00
04/16/2021	36858	BOND TRUST SERVICES	400.00
04/16/2021	36859	CHAD LEWIS	200.00
04/16/2021	36860	CITY OF GLENDALE	348.80
04/16/2021	36861	CONCENTRA	71.00
04/16/2021	36862	DAVIS & KUELTHAU S.C.	4,452.50
04/16/2021	36863	DIGGERS HOTLINE INC	144.00
04/16/2021	36864	DIVERSIFIED BENEFIT SERVICES	1,000.00
04/16/2021	36865	Draeger-Anderson, Susan	500.00
04/16/2021	36866	HERBST OIL	5,559.47
04/16/2021	36867	HUMPHREY SERVICE PARTS INC	680.37
04/16/2021	36868	KAPUR & ASSOCIATES	4,922.36
04/16/2021	36869	KAWAI, HIROKO	65.00
04/16/2021	36870	KRAVTSOV, SERGEY	37.50
04/16/2021	36871	LINCOLN CONTRACTORS SUPPLY	425.80
04/16/2021	36872	MADACC	752.01
04/16/2021	36873	Milwaukee Metropolitan Sewerage	6,325.00
04/16/2021	36874	OSWALT, GRETCHEN	9.50
04/16/2021	36875	PREMIUM WATERS INC.	51.90
04/16/2021	36876	SAFEBUILT LLC Lockbox #88135	1,878.86
04/16/2021	36877	SAVARY, ANNA	9.50
04/16/2021	36878	SECURIAN FINANCIAL GROUP	644.28
04/16/2021	36879	SPECTRUM ENTERPRISE	88.65
04/16/2021	36880	WE ENERGIES -	2,727.52
04/16/2021	36881	WIL-surge Electric Inc	66,500.00
04/16/2021	36882	ACCURATE APPRAISAL LLC	16,185.00
04/16/2021	36883	AMAZON/SYNCB	326.01
04/16/2021	36884	CDW GOVERNMENT	6,892.24
04/16/2021	36885	DAVIS & KUELTHAU S.C.	55.50
04/16/2021	36886	INTRADO SYSTEMS CORPS	112,992.51
04/16/2021	36887	NORTH SHORE BANK	2,597.50
04/16/2021	36888	Northland Business System	5,553.90
04/16/2021	36889	WI DEPT OF JUSTICE-93970	399.00
04/16/2021	999997527	CARTER, JULIE	725.23
Grand Totals:			269,088.66

Report Criteria:
Report type: Summary

Check Issue Date	Check Number	Payee	Amount
04/19/2021	36890	HUNGER TASK FORCE	946.61
Grand Totals:			<u>946.61</u>

Report Criteria:
Report type: Summary

Check Issue Date	Check Number	Payee	Amount
04/23/2021	36893	ELLING, JOHN	9.50
04/23/2021	36894	Mitel	1,028.13
04/23/2021	36895	POPA, IONEL	9.50
Grand Totals:			<u>1,047.13</u>

Report Criteria:
Report type: Summary

Check Issue Date	Check Number	Payee	Amount
04/30/2021	36896	Axon Enterprise	6,120.00
04/30/2021	36897	CITY OF MEQUON	1,150.96
04/30/2021	36898	Collaborative Summer Library Prog	588.38
04/30/2021	36899	COMPASS MINERALS AMERICA INC	3,098.50
04/30/2021	36900	DAVIS & KUELTHAU S.C.	7,039.46
04/30/2021	36901	DELTA DENTAL	133.20
04/30/2021	36902	EBSCO INDUSTRIES INC.,	89.36
04/30/2021	36903	EWALD AUTOMOTIVE GROUP	39,871.00
04/30/2021	36904	HUMPHREY SERVICE PARTS INC	152.56
04/30/2021	36905	KAPUR & ASSOCIATES	4,751.00
04/30/2021	36906	LINCOLN CONTRACTORS SUPPLY	43,712.75
04/30/2021	36907	MILWAUKEE COUNTY FEDERATED LI	682.13
04/30/2021	36908	Milwaukee Metropolitan Sewerage	66,238.52
04/30/2021	36909	NORTH SHORE HEALTH DEPARTMEN	7,281.25
04/30/2021	36910	OFFICE COPYING EQUIPMENT LTD	89.24
04/30/2021	36911	PACKERLAND RENT-A-MAT INC.	39.00
04/30/2021	36912	REGISTRATION FEE TRUST	165.50
04/30/2021	36913	UNEMPLOYMENT INSURANCE	747.91
04/30/2021	36914	UTILITY NETWORK LLC	1,995.00
04/30/2021	36915	WE ENERGIES -	7,328.65
04/30/2021	36916	WI DEPT OF JUSTICE - TIME	2,205.75
Grand Totals:			193,480.12

Report Criteria:

Report type: Summary

Check Issue Date	Check Number	Payee	Amount
05/07/2021	36920	ABRAHAM'S ON-SITE SHREDDING SE	45.00
05/07/2021	36921	ARCHIVESOCIAL	1,788.00
05/07/2021	36922	AT&T MOBILITY	27.69
05/07/2021	36923	ATM AMERICAN INDUSTRIAL MEDIC	186.00
05/07/2021	36924	BAKER TILLY VIRCHOW KRAUSE LLP	2,500.00
05/07/2021	36925	BUELOW VETTER BUIKEMA OLSON V	120.00
05/07/2021	36926	DAVIS & KUELTHAU S.C.	55.50
05/07/2021	36927	GREATAMERICA FINANCIAL SERVIC	107.00
05/07/2021	36928	HUMPHREY SERVICE PARTS INC	416.90
05/07/2021	36929	LOCOCO, VINCE	84.00
05/07/2021	36930	OZAUKEE COUNTY HIGHWAY DEPT	104.21
05/07/2021	36931	UNEMPLOYMENT INSURANCE	750.49
05/07/2021	36932	We Energies	3,345.48
Grand Totals:			<u>9,530.27</u>

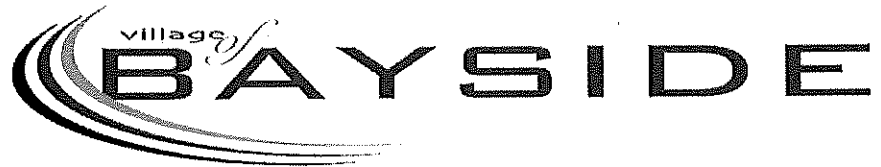

APRIL 2021

FINANCIAL STATEMENT

VILLAGE OF BAYSIDE
REVENUES WITH COMPARISON TO BUDGET
FOR THE 4 MONTHS ENDING APRIL 30, 2021

GENERAL FUND

	PERIOD ACTUAL	YTD ACTUAL	BUDGET	UNEARNED	%	
<u>TAXES</u>						
10-41100	PROPERTY TAXES	361,406.95	2,543,969.35	3,226,561.00	682,591.65	78.8
10-41300	INTEREST ON DELINQUENT TAXES	1,398.33	4,612.37	12,000.00	7,387.63	38.4
10-41500	PAYMENT IN LIEU OF TAXES	.00	14,172.94	46,533.00	32,360.06	30.5
	TOTAL TAXES	362,805.28	2,562,754.66	3,285,094.00	722,339.34	78.0
<u>INTERGOVERNMENTAL</u>						
10-43210	COMMUNITY DEVELOPMENT BLOC	.00	.00	5,598.00	5,598.00	.0
10-43225	PUBLIC SAFETY COMMUNICATION	.00	97,488.00	97,488.00	.00	100.0
10-43235	NORTH SHORE LIBRARY REVENUE	.00	.00	19,521.00	19,521.00	.0
10-43410	STATE SHARED REVENUES	.00	.00	60,296.00	60,296.00	.0
10-43415	VIDEO SERVICE PROVIDER AID	.00	.00	7,330.00	7,330.00	.0
10-43510	RECYCLING GRANT	.00	.00	25,676.00	25,676.00	.0
10-43530	EXEMPT COMPUTER AID	.00	.00	15,160.00	15,160.00	.0
10-43535	PERSONAL PROPERTY AID	.00	.00	1,737.00	1,737.00	.0
10-43540	STATE TRANSPORTATION AIDS	106,884.71	176,221.42	412,020.00	235,798.58	42.8
10-43545	ST 32 HIGHWAY AIDS	4,246.23	8,492.46	16,954.00	8,461.54	50.1
10-43555	INTERGOVERNMENTAL GRANT	.00	.00	10,000.00	10,000.00	.0
10-43600	EXPENDITURE RESTRAINT	.00	.00	78,900.00	78,900.00	.0
	TOTAL INTERGOVERNMENTAL	111,130.94	282,201.88	750,680.00	468,478.12	37.6
<u>LICENSES & PERMITS</u>						
10-44100	OPERATORS LICENSE	.00	165.00	1,000.00	835.00	16.5
10-44120	LIQUOR LICENSE	.00	2,500.00	2,900.00	400.00	86.2
10-44140	CIGARETTE LICENSE	.00	200.00	200.00	.00	100.0
10-44220	ANIMAL LICENSES	120.00	642.68	1,750.00	1,107.32	36.7
10-44300	CABLE FRANCHISE FEES	3,361.64	20,009.83	65,000.00	44,990.17	30.8
10-44415	ARC APPLICATION FEES	420.00	900.00	2,000.00	1,100.00	45.0
10-44420	OCCUPANCY PERMITS	.00	100.00	250.00	150.00	40.0
10-44435	TRANSIENT MERCHANT PERMIT	.00	.00	300.00	300.00	.0
10-44460	BUILDING PERMITS	5,073.40	17,233.58	65,000.00	47,766.42	26.5
10-44480	VACANT PROPERTY FEE	.00	750.00	.00	750.00	.0
10-44495	EXCAVATION/RIGHT OF WAY/PRIVL	1,000.00	2,950.00	15,000.00	12,050.00	19.7
10-44530	RUMMAGE SALE PERMITS	15.00	45.00	120.00	75.00	37.5
10-44535	DUMPSTER PERMITS	550.00	2,065.00	2,000.00	65.00	103.3
10-44540	SIGN PERMITS	380.00	680.00	500.00	180.00	136.0
10-44550	CONDITIONAL USE APPLICATION	.00	300.00	300.00	.00	100.0
10-44555	BOARD OF ZONING APPEALS FEES	1,000.00	2,000.00	500.00	1,500.00	400.0
10-44560	TREE PROGRAM	3,725.00	6,900.00	5,000.00	1,900.00	138.0
10-44570	SPECIAL EVENT PERMITS	.00	240.00	50.00	190.00	480.0
	TOTAL LICENSES & PERMITS	15,645.04	57,681.09	161,870.00	104,188.91	35.6

VILLAGE OF BAYSIDE
REVENUES WITH COMPARISON TO BUDGET
FOR THE 4 MONTHS ENDING APRIL 30, 2021

GENERAL FUND

	PERIOD ACTUAL	YTD ACTUAL	BUDGET	UNEARNED	%
<u>FINES & FORFEITURES</u>					
10-45100 FINES & FORFEITURES	5,907.09	15,196.70	40,000.00	24,803.30	38.0
10-45125 NOTARY/FINGER	25.00	25.00	100.00	75.00	25.0
TOTAL FINES & FORFEITURES	5,932.09	15,221.70	40,100.00	24,878.30	38.0
<u>PUBLIC CHARGES FOR SERVICES</u>					
10-46110 PROPERTY STATUS REVENUE	850.00	1,300.00	4,000.00	2,700.00	32.5
10-46120 PUBLICATION FEES	.00	100.00	175.00	75.00	57.1
10-46130 DATA SALES	106.00	510.70	550.00	39.30	92.9
10-46150 BRICK DONATIONS	350.00	350.00	.00	350.00-	.0
10-46310 SPECIAL PICKUPS	1,326.74	3,264.74	8,000.00	4,735.26	40.8
10-46315 MULCH DELIVERIES	2,194.50	2,757.00	4,800.00	2,043.00	57.4
10-46330 WELL PERMIT/ABANDONMENT FEES	.00	200.00	.00	200.00-	.0
10-46400 EQUIPMENT RENTAL- SEWER FUND	.00	20,000.00	20,000.00	.00	100.0
10-46415 EQUIPMENT RENTAL- STORMWATER	.00	20,000.00	20,000.00	.00	100.0
10-46710 PARK FACILITY RENTAL & PROGRA	228.00	312.00	800.00	488.00	39.0
10-46715 PUBLIC WORKS SERVICE REVENUE	45.00	45.00	300.00	255.00	15.0
TOTAL PUBLIC CHARGES FOR SERVI	5,100.24	48,839.44	58,625.00	9,785.56	83.3
<u>MISCELLANEOUS REVENUE</u>					
10-48100 INTEREST	6,593.22	29,004.15	110,000.00	80,995.85	26.4
10-48120 REALIZED/UNREALIZED GAIN/LOSS	(2,236.08)	(29,601.52)	.00	29,601.52	.0
10-48200 MISCELLANEOUS REVENUE	304.68	584.80	500.00	84.80-	117.0
10-48210 COPIES	.00	.00	150.00	150.00	.0
10-48220 FALSE ALARM FEES	620.00	930.00	5,000.00	4,070.00	18.6
10-48230 RECYCLING PROCEEDS	1,364.47	1,957.07	500.00	1,457.07-	391.4
10-48240 CREDIT CARD REVENUE	.00	2,635.08	7,000.00	4,364.92	37.6
10-48310 EQUIPMENT SALE PROCEEDS	.00	1,995.79	.00	1,995.79-	.0
10-48500 DONATIONS	4,000.00	4,000.00	10,000.00	6,000.00	40.0
TOTAL MISCELLANEOUS REVENUE	10,646.29	11,505.37	133,150.00	121,644.63	8.6
TOTAL FUND REVENUE	511,259.88	2,978,204.14	4,429,519.00	1,451,314.86	67.2

VILLAGE OF BAYSIDE
EXPENDITURES WITH COMPARISON TO BUDGET
FOR THE 4 MONTHS ENDING APRIL 30, 2021

GENERAL FUND

	PERIOD ACTUAL	YTD ACTUAL	BUDGET	UNEXPENDED	%	
<u>GENERAL GOVERNMENT</u>						
10-51000-110	WAGES FT	19,356.38	65,185.13	236,083.00	170,897.87	27.6
10-51000-117	HEALTH INSURANCE BUYOUT	166.68	666.72	2,000.00	1,333.28	33.3
10-51000-119	DENTAL INSURANCE BUYOUT	11.32	45.28	208.00	162.72	21.8
10-51000-120	TRUSTEE WAGES	700.00	2,300.00	8,400.00	6,100.00	27.4
10-51000-125	ELECTION WAGES	960.00	1,528.50	3,000.00	1,471.50	51.0
10-51000-130	ELECTIONS SUPPLIES	195.84	1,856.86	3,800.00	1,943.14	48.9
10-51000-150	WISCONSIN RETIREMENT SYSTEM	1,306.57	5,019.63	15,017.00	9,997.37	33.4
10-51000-151	SOCIAL SECURITY	1,520.63	5,709.19	20,402.00	14,692.81	28.0
10-51000-152	LIFE INSURANCE	65.63	336.78	796.00	459.22	42.3
10-51000-153	HEALTH INSURANCE	1,397.69	7,104.11	17,393.00	10,288.89	40.8
10-51000-154	DENTAL INSURANCE	36.23	184.41	362.00	177.59	50.9
10-51000-208	LEGAL SERVICES-MISC	4,452.50	117.00	2,000.00	1,883.00	5.9
10-51000-210	CONTRACTUAL SERVICES	57.77	3,398.60	13,379.00	9,980.40	25.4
10-51000-211	LEGAL COUNSEL - CONTRACTED	5,028.17	15,084.51	58,583.00	43,498.49	25.8
10-51000-214	AUDIT SERVICES	13,191.04	13,191.04	18,743.00	5,551.96	70.4
10-51000-217	PUBLIC HEALTH SERVICES	7,281.25	14,562.50	29,395.00	14,832.50	49.5
10-51000-219	ASSESSOR SERVICES	16,185.00	21,165.00	24,900.00	3,735.00	85.0
10-51000-221	TELECOMMUNICATIONS	348.42	896.33	2,614.00	1,717.67	34.3
10-51000-225	COMPUTER SUPPORT	.00	.00	1,000.00	1,000.00	.0
10-51000-226	BENEFIT ADMINISTRATIVE FEES	82.19	94.04	200.00	105.96	47.0
10-51000-229	BANKING FEES	454.97	1,891.82	4,200.00	2,308.18	45.0
10-51000-230	MATERIALS & SUPPLIES	43.83	362.89	2,200.00	1,837.11	16.5
10-51000-238	FINANCIAL ADVISING SERVICES	400.00	800.00	6,000.00	5,200.00	13.3
10-51000-300	ADMINISTRATIVE	.00	.00	800.00	800.00	.0
10-51000-310	OFFICE SUPPLIES	5.49	449.66	4,000.00	3,550.34	11.2
10-51000-311	POSTAGE	31.80	2,331.80	2,600.00	268.20	89.7
10-51000-321	DUES & SUBSCRIPTIONS	60.00	1,972.77	6,430.00	4,457.23	30.7
10-51000-322	TRAINING, SAFETY & CERTS	45.00	1,909.00	8,255.00	6,346.00	23.1
10-51000-323	WELLNESS	.00	.00	1,000.00	1,000.00	.0
10-51000-324	PUBLICATIONS/PRINTING	.00	.00	100.00	100.00	.0
10-51000-350	EQUIPMENT REPLACEMENT	.00	.00	2,000.00	2,000.00	.0
10-51000-390	PUBLIC RELATIONS	.00	.00	100.00	100.00	.0
10-51000-500	CONTINGENCY	.00	.00	50,000.00	50,000.00	.0
10-51000-501	COVID 19 CONTINGENCY	41,882.33	41,882.33	89,554.00	47,671.67	46.8
10-51000-510	GENERAL LIABILITY	.00	39,158.69	44,307.00	5,148.31	88.4
10-51000-511	AUTO LIABILITY	.00	4,427.00	5,606.00	1,179.00	79.0
10-51000-512	BOILER INSURANCE	.00	708.00	708.00	.00	100.0
10-51000-513	WORKERS COMPENSATION	.00	50,272.18	50,523.00	250.82	99.5
10-51000-515	COMMERCIAL CRIME POLICY	.00	125.24	166.00	40.76	75.5
10-51000-516	PROPERTY INSURANCE	.00	7,099.07	7,418.00	318.93	95.7
10-51000-517	PUBLIC OFFICIAL BONDS	.00	7,399.07	9,816.00	2,416.93	75.4
10-51000-591	MUNICIPAL CODE	.00	.00	4,000.00	4,000.00	.0
	TOTAL GENERAL GOVERNMENT	115,255.75	319,235.15	758,058.00	438,822.85	42.1

VILLAGE OF BAYSIDE
EXPENDITURES WITH COMPARISON TO BUDGET
FOR THE 4 MONTHS ENDING APRIL 30, 2021

GENERAL FUND

	PERIOD ACTUAL	YTD ACTUAL	BUDGET	UNEXPENDED	%	
<u>POLICE</u>						
10-52100-110	WAGES FT	82,998.21	315,127.65	1,108,010.00	792,882.35	28.4
10-52100-111	OVERTIME	402.74	227.97	30,000.00	29,772.03	.8
10-52100-116	HOLIDAY PAY	.00	.00	36,286.00	36,286.00	.0
10-52100-117	HEALTH INSURANCE BUYOUT	.00	.00	12,600.00	12,600.00	.0
10-52100-118	SHIFT DIFFERENTIAL PAY	250.00	800.00	3,360.00	2,560.00	23.8
10-52100-119	DENTAL INSURANCE BUYOUT	18.88	75.52	680.00	604.48	11.1
10-52100-150	WISCONSIN RETIREMENT SYSTEM	8,704.81	32,697.61	122,031.00	89,333.39	26.8
10-52100-151	SOCIAL SECURITY	6,378.09	24,121.72	91,673.00	67,551.28	26.3
10-52100-152	LIFE INSURANCE	68.54	342.56	855.00	512.44	40.1
10-52100-153	HEALTH INSURANCE	8,812.49	44,010.75	155,107.00	111,096.25	28.4
10-52100-154	DENTAL INSURANCE	126.38	630.76	2,705.00	2,074.24	23.3
10-52100-209	HOUSE OF CORRECTION FEES	.00	.00	751.00	751.00	.0
10-52100-210	CONTRACTUAL SERVICES	8,745.27	14,385.28	36,174.00	21,788.72	39.8
10-52100-211	LEGAL COUNSEL-CONTRACTED	2,011.29	6,033.87	24,897.00	18,863.13	24.2
10-52100-213	LEGAL COUNSEL-PERSONNEL	55.50	415.50	1,000.00	584.50	41.6
10-52100-215	MADACC	488.06	976.12	1,300.00	323.88	75.1
10-52100-221	TELECOMMUNICATIONS	552.07	1,767.25	5,195.00	3,427.75	34.0
10-52100-225	COMPUTER SUPPORT SERVICES	.00	.00	5,000.00	5,000.00	.0
10-52100-226	BENEFIT ADMINISTRATIVE FEES	205.02	1,580.11	1,586.00	5.89	99.6
10-52100-230	MATERIALS & SUPPLIES	8,374.20	13,299.41	15,250.00	1,950.59	87.2
10-52100-231	FLEET MAINTENANCE	496.38	3,838.62	7,000.00	3,161.38	54.8
10-52100-310	OFFICE SUPPLIES	.00	48.37	1,000.00	951.63	4.8
10-52100-311	POSTAGE	.00	611.00	800.00	189.00	76.4
10-52100-321	DUES & SUBSCRIPTIONS	.00	425.00	990.00	565.00	42.9
10-52100-322	TRAINING, SAFETY & CERTIFICATI	2,474.97	2,225.97	4,000.00	6,225.97	(55.7)
10-52100-323	AMMUNITION	1,141.00	1,141.00	1,600.00	459.00	71.3
10-52100-330	UNIFORM SUPPLIES	758.39	3,724.38	6,500.00	2,775.62	57.3
10-52100-333	MEDICAL SUPPLIES	.00	.00	1,090.00	1,090.00	.0
10-52100-340	FUEL MAINTENANCE	1,777.34	5,582.39	18,060.00	12,477.61	30.9
10-52100-519	GASB 45 OBLIGATIONS	11,615.51	33,908.11	46,334.00	12,425.89	73.2
	TOTAL POLICE	140,699.72	503,544.98	1,741,834.00	1,238,289.02	28.9
<u>NORTH SHORE FIRE DEPT</u>						
10-52200-224	NORTH SHORE FIRE DEPARTMENT	.00	432,342.00	864,506.00	432,164.00	50.0
	TOTAL NORTH SHORE FIRE DEPT	.00	432,342.00	864,506.00	432,164.00	50.0
<u>BUILDING INSPECTION</u>						
10-52400-110	WAGES FT	.00	20,000.00	20,000.00	.00	100.0
10-52400-250	BUILDING INSPECTIONS	1,878.86	6,731.75	35,750.00	29,018.25	18.8
	TOTAL BUILDING INSPECTION	1,878.86	26,731.75	55,750.00	29,018.25	48.0

VILLAGE OF BAYSIDE
EXPENDITURES WITH COMPARISON TO BUDGET
FOR THE 4 MONTHS ENDING APRIL 30, 2021

GENERAL FUND

	PERIOD ACTUAL	YTD ACTUAL	BUDGET	UNEXPENDED	%
--	---------------	------------	--------	------------	---

DEPARTMENT OF PUBLIC WORKS

10-53000-110	WAGES FT	31,524.12	132,760.09	303,960.00	171,199.91	43.7
10-53000-111	OVERTIME	.00	4,696.14	4,200.00	-496.14	111.8
10-53000-150	WISCONSIN RETIREMENT SYSTEM	1,922.65	7,628.28	20,057.00	12,428.72	38.0
10-53000-151	SOCIAL SECURITY	2,106.87	8,587.34	23,574.00	14,986.66	36.4
10-53000-152	LIFE INSURANCE	62.57	287.48	557.00	269.52	51.6
10-53000-153	HEALTH INSURANCE	9,805.48	44,524.91	91,315.00	46,790.09	48.8
10-53000-154	DENTAL INSURANCE	211.87	962.03	1,903.00	940.97	50.6
10-53000-200	FACILITY MAINTENANCE & SUPPLIE	769.20	37,422.37	97,500.00	60,077.63	38.4
10-53000-201	CLEANING & JANITORIAL SERVICES	595.34	2,369.68	11,400.00	9,030.32	20.8
10-53000-202	HVAC MAINTENANCE	.00	.00	4,200.00	4,200.00	.0
10-53000-210	CONTRACTUAL SERVICES	35.13	981.59	38,727.00	37,745.41	2.5
10-53000-216	ENGINEERING	1,404.00	1,327.00	20,000.00	18,673.00	6.6
10-53000-220	UTILITIES	13,074.17	13,176.67	55,000.00	41,823.33	24.0
10-53000-221	TELECOMMUNICATIONS	248.15	695.15	2,300.00	1,604.85	30.2
10-53000-226	BENEFIT ADMINISTRATIVE FEES	85.18	91.94	114.00	22.06	80.7
10-53000-230	MATERIALS & SUPPLIES	554.39	2,212.89	5,100.00	2,887.11	43.4
10-53000-231	FLEET MAINTENANCE	3,110.19	10,350.58	31,163.00	20,812.42	33.2
10-53000-233	TOOLS	335.45	493.02	1,500.00	1,006.98	32.9
10-53000-310	OFFICE SUPPLIES	.00	.00	150.00	150.00	.0
10-53000-321	DUES & SUBSCRIPTIONS	16.53	16.53	525.00	541.53	(3.2)
10-53000-322	TRAINING, SAFETY & CERTIFICATI	465.00	952.00	1,950.00	998.00	48.8
10-53000-330	UNIFORM SUPPLIES	161.22	201.21	1,800.00	1,598.79	11.2
10-53000-334	WINTER OPERATIONS	3,190.64	19,401.30	40,000.00	20,598.70	48.5
10-53000-340	FUEL MAINTENANCE	4,132.29	2,162.14	20,000.00	17,837.86	10.8
10-53000-350	EQUIPMENT REPLACEMENT	.00	4,894.84	6,200.00	1,305.16	79.0
10-53000-360	EQUIPMENT RENTAL	4,845.00	7,695.00	8,500.00	805.00	90.5
10-53000-370	TIPPING FEES	.00	8,515.96	71,000.00	62,484.04	12.0
10-53000-377	YARD WASTE TUB GRINDING	.00	.00	8,500.00	8,500.00	.0
10-53000-390	PUBLIC RELATIONS	.00	.00	100.00	100.00	.0
10-53000-400	STREET MAINTENANCE	.00	.00	7,700.00	7,700.00	.0
10-53000-450	SIGNAGE	.00	.00	2,000.00	2,000.00	.0
10-53000-460	FORESTRY & LANDSCAPING	.00	.00	7,000.00	7,000.00	.0
10-53000-465	TREE DISEASE MITIGATION	.00	32.98	15,000.00	14,967.02	.2
	TOTAL DEPARTMENT OF PUBLIC WO	78,622.38	312,406.06	902,995.00	590,588.94	34.6

NORTH SHORE LIBRARY

10-55100-227	NORTH SHORE LIBRARY	.00	.00	160,277.00	160,277.00	.0
	TOTAL NORTH SHORE LIBRARY	.00	.00	160,277.00	160,277.00	.0

VILLAGE OF BAYSIDE
EXPENDITURES WITH COMPARISON TO BUDGET
FOR THE 4 MONTHS ENDING APRIL 30, 2021

GENERAL FUND

	PERIOD ACTUAL	YTD ACTUAL	BUDGET	UNEXPENDED	%
<u>PARKS</u>					
10-55200-110 WAGES FT	.00	.00	5,200.00	5,200.00	.0
10-55200-151 SOCIAL SECURITY	.00	.00	398.00	398.00	.0
10-55200-230 MATERIALS & SUPPLIES	7.46	7.46	500.00	492.54	1.5
10-55200-235 COMMUNITY EVENTS	8.05-	8.05-	15,000.00	15,008.05	(.1)
TOTAL PARKS	.59-	.59-	21,098.00	21,098.59	.0
<u>DEPARTMENT 59242</u>					
10-59242-900 TRANSFER OUT	.00	46,000.00	46,000.00	.00	100.0
TOTAL DEPARTMENT 59242	.00	46,000.00	46,000.00	.00	100.0
TOTAL FUND EXPENDITURES	336,456.12	1,640,259.35	4,550,518.00	2,910,258.65	36.1
NET REVENUE OVER EXPENDITURES	174,803.76	1,337,944.79	120,999.00-	-1,458,943.79	1105.8

VILLAGE OF BAYSIDE
 REVENUES WITH COMPARISON TO BUDGET
 FOR THE 4 MONTHS ENDING APRIL 30, 2021

SANITARY SEWER FUND

	PERIOD ACTUAL	YTD ACTUAL	BUDGET	UNEXPENDED	%
<u>PUBLIC CHARGES FOR SERVICES</u>					
20-46410 RESIDENTIAL SEWER	10,979.60	788,144.00	795,088.00	6,944.00	99.1
20-46420 COMMERCIAL SEWER	22,900.62	22,900.62	100,000.00	77,099.38	22.9
20-46425 POLICE LEASE REVENUE	.00	34,230.00	34,230.00	.00	100.0
20-46450 SEWER INTERGOVERNMENTAL REV	11,709.00	11,709.00	.00	-11,709.00	.0
TOTAL PUBLIC CHARGES FOR SERVI	45,589.22	856,983.62	929,318.00	72,334.38	92.2
<u>MISCELLANEOUS REVENUE</u>					
20-48100 INTEREST	8.55	36.60	.00	-36.60	.0
TOTAL MISCELLANEOUS REVENUE	8.55	36.60	.00	-36.60	.0
TOTAL FUND REVENUE	45,597.77	857,020.22	929,318.00	72,297.78	92.2

VILLAGE OF BAYSIDE
EXPENDITURES WITH COMPARISON TO BUDGET
FOR THE 4 MONTHS ENDING APRIL 30, 2021

SANITARY SEWER FUND

	PERIOD ACTUAL	YTD ACTUAL	BUDGET	UNEXPENDED	%	
<u>GENERAL SEWER</u>						
20-51000-110	WAGES FT	4,844.99	39,638.17	123,597.00	83,958.83	32.1
20-51000-111	OVERTIME	.00	.00	900.00	900.00	.0
20-51000-117	HEALTH INSURANCE BUYOUT	41.66	166.64	500.00	333.36	33.3
20-51000-119	DENTAL INSURANCE BUYOUT	3.78	15.12	54.00	38.88	28.0
20-51000-150	WISCONSIN RETIREMENT SYSTEM	327.05	1,054.67	8,404.00	7,349.33	12.6
20-51000-151	SOCIAL SECURITY	362.90	1,175.60	9,566.00	8,390.40	12.3
20-51000-152	LIFE INSURANCE	13.80	94.04	263.00	168.96	35.8
20-51000-153	HEALTH INSURANCE	556.98	5,359.78	21,741.00	16,381.22	24.7
20-51000-154	DENTAL INSURANCE	12.80	119.23	453.00	333.77	26.3
20-51000-210	CONTRACTUAL SERVICES	72,589.04	72,691.09	274,993.00	202,301.91	26.4
20-51000-214	AUDIT SERVICES	2,480.84	2,480.84	3,525.00	1,044.16	70.4
20-51000-216	ENGINEERING	6,546.36	6,546.36	34,678.00	28,131.64	18.9
20-51000-220	UTILITIES	1,622.58	3,732.28	6,000.00	2,267.72	62.2
20-51000-221	TELECOMMUNICATIONS	.00	19.85	100.00	80.15	19.9
20-51000-226	BENEFIT ADMINISTRATIVE FEES	19.43	20.79	23.00	2.21	90.4
20-51000-230	MATERIALS & SUPPLIES	.13	.13	2,000.00	1,999.87	.0
20-51000-231	FLEET MAINTENANCE	.00	238.72	1,500.00	1,261.28	15.9
20-51000-232	LIFT STATION MAINTENANCE	.00	.00	10,550.00	10,550.00	.0
20-51000-233	TOOLS	.00	.00	1,500.00	1,500.00	.0
20-51000-234	DIGGERS HOTLINE	144.00	240.00	2,000.00	1,760.00	12.0
20-51000-311	POSTAGE	.00	300.00	400.00	100.00	75.0
20-51000-322	TRAINING, SAFETY & CERTIFICATI	.00	96.00	2,400.00	2,304.00	4.0
20-51000-340	FUEL MAINTENANCE	.00	3,200.00	3,200.00	.00	100.0
20-51000-350	EQUIPMENT REPLACEMENT	.00	.00	1,000.00	1,000.00	.0
20-51000-360	EQUIPMENT RENTAL-GENENERAL FU	.00	20,000.00	20,000.00	.00	100.0
20-51000-510	GENERAL LIABILITY INSURANCE	.00	1,769.62	2,134.00	364.38	82.9
20-51000-513	WORKERS COMPENSATION	.00	1,649.26	1,652.00	2.74	99.8
20-51000-515	COMMERCIAL CRIME POLICY	.00	8.30	11.00	2.70	75.5
20-51000-516	PROPERTY INSURANCE	.00	2,789.10	2,914.00	124.90	95.7
20-51000-801	CAPITAL PROJECTS	66,500.00	4,437.10	320,331.00	324,768.10	(1.4)
	TOTAL GENERAL SEWER	156,066.34	158,968.49	856,389.00	697,420.51	18.6
<u>DEPRECIATION</u>						
20-53000-700	DEPRECIATION	.00	.00	3,138.00	3,138.00	.0
	TOTAL DEPRECIATION	.00	.00	3,138.00	3,138.00	.0
<u>DEBT</u>						
20-58100-617	PRINCIPAL REDEMPTION - CWFL	.00	.00	80,806.00	80,806.00	.0
20-58100-618	PRINCIPAL REDEMPTION - BOND	.00	.00	173,750.00	173,750.00	.0
20-58100-621	INTEREST - BOND	3,569.98	19,603.73	48,426.00	28,822.27	40.5
20-58100-626	INTEREST-CLEAN WATER FUND LOA	3,959.86	3,959.86	6,964.00	3,004.14	56.9
	TOTAL DEBT	7,529.84	23,563.59	309,946.00	286,382.41	7.6

VILLAGE OF BAYSIDE
EXPENDITURES WITH COMPARISON TO BUDGET
FOR THE 4 MONTHS ENDING APRIL 30, 2021

SANITARY SEWER FUND

	PERIOD ACTUAL	YTD ACTUAL	BUDGET	UNEXPENDED	%
<u>AMORTIZATION OF DEBT</u>					
20-58291-226 BOND ISSUANCE FEES	39,446.38	39,446.38	.00	-39,446.38	.0
TOTAL AMORTIZATION OF DEBT	39,446.38	39,446.38	.00	-39,446.38	.0
TOTAL FUND EXPENDITURES	203,042.56	221,978.46	1,169,473.00	947,494.54	19.0
NET REVENUE OVER EXPENDITURES	157,444.79-	635,041.76	240,155.00-	-875,196.76	264.4

VILLAGE OF BAYSIDE
REVENUES WITH COMPARISON TO BUDGET
FOR THE 4 MONTHS ENDING APRIL 30, 2021

STORMWATER UTILITY FUND

	PERIOD ACTUAL	YTD ACTUAL	BUDGET	UNEXPENDED	%
22-43210 INTERGOVERNMENTAL GRANTS	.00	.00	40,000.00	40,000.00	.0
TOTAL SOURCE 43	.00	.00	40,000.00	40,000.00	.0
<u>PUBLIC CHARGES FOR SERVICES</u>					
22-46405 RESIDENTIAL STORMWATER	5,612.00	384,714.80	384,178.00	-536.80	100.1
22-46425 COMMERCIAL STORMWATER	32,113.45	32,113.45	154,449.00	122,335.55	20.8
22-46430 RIGHT-OF-WAY MANAGEMENT	4,600.00	6,700.00	10,000.00	3,300.00	67.0
TOTAL PUBLIC CHARGES FOR SERVI	42,325.45	423,528.25	548,627.00	125,098.75	77.2
<u>OTHER FINANCING SOURCES</u>					
22-49100 PROCEEDS OF LONG-TERM DEBT	310,000.00	310,000.00	.00	-310,000.00	.0
22-49120 PROCEEDS OF PREMIUM	10,890.00	10,890.00	.00	-10,890.00	.0
TOTAL OTHER FINANCING SOURCES	320,890.00	320,890.00	.00	-320,890.00	.0
TOTAL FUND REVENUE	363,215.45	744,418.25	588,627.00	-155,791.25	126.5

VILLAGE OF BAYSIDE
EXPENDITURES WITH COMPARISON TO BUDGET
FOR THE 4 MONTHS ENDING APRIL 30, 2021

STORMWATER UTILITY FUND

	PERIOD ACTUAL	YTD ACTUAL	BUDGET	UNEXPENDED	%
22-53000-110 WAGES FT	4,169.56	29,203.73	123,597.00	94,393.27	23.6
22-53000-111 OVERTIME	.00	.00	900.00	900.00	.0
22-53000-117 HEALTH INSURANCE BUYOUT	41.66	166.64	500.00	333.36	33.3
22-53000-119 DENTAL INSURANCE BUYOUT	3.78	15.12	54.00	38.88	28.0
22-53000-150 WISCONSIN RETIREMENT SYSTEM	281.42	1,149.46	8,404.00	7,254.54	13.7
22-53000-151 SOCIAL SECURITY	314.86	1,277.24	9,566.00	8,288.76	13.4
22-53000-152 LIFE INSURANCE	12.51	67.99	263.00	195.01	25.9
22-53000-153 HEALTH INSURANCE	371.26	3,673.47	21,741.00	18,067.53	16.9
22-53000-154 DENTAL INSURANCE	8.77	82.78	453.00	370.22	18.3
22-53000-210 CONTRACTUAL SERVICES	25.52	93.22	1,029.00	935.78	9.1
22-53000-214 AUDIT SERVICES	1,164.06	1,164.06	1,654.00	489.94	70.4
22-53000-216 ENGINEERING	1,723.00	1,723.00	62,164.00	60,441.00	2.8
22-53000-220 UTILITY EXPENSES	319.43	319.43	2,400.00	2,080.57	13.3
22-53000-221 TELECOMMUNICATIONS	.00	.00	100.00	100.00	.0
22-53000-226 BENEFIT ADMINISTRATIVE FEES	13,820.91	13,822.27	23.00	-13,799.27	60096.8
22-53000-230 MATERIALS & SUPPLIES	82.38	2,114.57	2,500.00	385.43	84.6
22-53000-232 LIFT STATION MAINTENANCE	.00	.00	2,000.00	2,000.00	.0
22-53000-322 TRAINING, SAFETY & CERTIFICATI	.00	.00	1,000.00	1,000.00	.0
22-53000-327 CULVERT MATERIALS	.00	.00	27,000.00	27,000.00	.0
22-53000-328 LANDSCAPING MATERIALS	.00	224.00	37,000.00	36,776.00	.6
22-53000-329 EXCAVATION AND DISPOSAL	.00	.00	15,000.00	15,000.00	.0
22-53000-340 FUEL MAINTENANCE	.00	2,500.00	2,500.00	.00	100.0
22-53000-350 EQUIPMENT REPLACEMENT	44,138.55	44,138.55	62,000.00	17,861.45	71.2
22-53000-360 EQUIPMENT RENTAL	.00	20,000.00	20,000.00	.00	100.0
22-53000-510 GENERAL LIABILITY INSURANCE	.00	2,182.30	2,634.00	451.70	82.9
22-53000-513 WORKERS COMPENSATION	.00	1,617.10	1,620.00	2.90	99.8
22-53000-515 COMMERCIAL CRIME POLICY	.00	8.30	11.00	2.70	75.5
22-53000-516 PROPERTY INSURANCE	.00	2,707.72	2,829.00	121.28	95.7
22-53000-801 CAPITAL PROJECTS	.00	20,503.51	163,331.00	142,827.49	12.6
TOTAL DEPARTMENT 53000	66,477.67	148,754.46	572,273.00	423,518.54	26.0
TRANSFER TO OTHER FUND					
22-59200-900 ADMINISTRATIVE/TRANSFER TO	.00	64,430.00	64,430.00	.00	100.0
TOTAL TRANSFER TO OTHER FUND	.00	64,430.00	64,430.00	.00	100.0
TOTAL FUND EXPENDITURES	66,477.67	213,184.46	636,703.00	423,518.54	33.5
NET REVENUE OVER EXPENDITURES	296,737.78	531,233.79	48,076.00-	-579,309.79	1105.0

VILLAGE OF BAYSIDE
REVENUES WITH COMPARISON TO BUDGET
FOR THE 4 MONTHS ENDING APRIL 30, 2021

PUBLIC SAFETY COMMUNICATIONS

	PERIOD ACTUAL	YTD ACTUAL	BUDGET	UNEXPENDED	%	
<u>TAXES</u>						
26-41100	PROPERTY TAXES	.00	297,783.00	297,783.00	.00	100.0
	TOTAL TAXES	.00	297,783.00	297,783.00	.00	100.0
<u>SOURCE 46</u>						
26-46220	INTERGOVERNMENTAL REVENUE	3,262.50	93,373.21	266,538.00	173,164.79	35.0
	TOTAL SOURCE 46	3,262.50	93,373.21	266,538.00	173,164.79	35.0
<u>INTERGOVERNMENT REVENUE</u>						
26-47130	CONTRACT REVENUE	38,414.06	1,042,241.86	2,084,484.00	1,042,242.14	50.0
	TOTAL INTERGOVERNMENT REVENUE	38,414.06	1,042,241.86	2,084,484.00	1,042,242.14	50.0
<u>MISCELLANEOUS REVENUE</u>						
26-48100	CONSOLIDATED SERVICE BILLINGS	12,648.17	44,487.51	53,025.00	8,537.49	83.9
	TOTAL MISCELLANEOUS REVENUE	12,648.17	44,487.51	53,025.00	8,537.49	83.9
	TOTAL FUND REVENUE	54,324.73	1,477,885.58	2,701,830.00	1,223,944.42	54.7

VILLAGE OF BAYSIDE
EXPENDITURES WITH COMPARISON TO BUDGET
FOR THE 4 MONTHS ENDING APRIL 30, 2021

PUBLIC SAFETY COMMUNICATIONS

	PERIOD ACTUAL	YTD ACTUAL	BUDGET	UNEXPENDED	%	
<u>PUBLIC SAFETY COMMUNICATIONS</u>						
26-51000-110	WAGES FT	95,636.55	355,371.99	1,502,249.00	1,146,877.01	23.7
26-51000-111	OVERTIME	5,144.54	17,898.77	35,000.00	17,101.23	51.1
26-51000-116	HOLIDAY PAY	670.64	7,565.68	30,902.00	23,336.32	24.5
26-51000-117	HEALTH INSURANCE BUYOUT	666.66	2,833.30	7,500.00	4,666.70	37.8
26-51000-119	DENTAL INSURANCE BUYOUT	37.76	151.04	997.00	845.96	15.2
26-51000-150	WISCONSIN RETIREMENT SYSTEM	6,820.92	25,644.71	105,850.00	80,205.29	24.2
26-51000-151	SOCIAL SECURITY	7,384.44	27,642.89	120,551.00	92,908.11	22.9
26-51000-152	LIFE INSURANCE	187.40	835.22	2,550.00	1,714.78	32.8
26-51000-153	HEALTH INSURANCE	21,415.35	107,954.20	392,087.00	284,132.80	27.5
26-51000-154	DENTAL INSURANCE	449.24	2,265.87	7,157.00	4,891.13	31.7
26-51000-180	RECRUITMENT	67.95	276.35	1,000.00	723.65	27.6
26-51000-200	FACILITY MAINTENANCE & SUPPLIE	9.36	900.23	14,298.00	13,397.77	6.3
26-51000-201	CLEANING & JANITORIAL SERVICES	855.12	3,403.72	11,183.00	7,779.28	30.4
26-51000-210	CONTRACTUAL SERVICES	124.35	555.97	2,853.00	2,297.03	19.5
26-51000-213	LEGAL COUNSEL-PERSONNEL	.00	.00	1,000.00	1,000.00	.0
26-51000-214	AUDIT SERVICES	1,164.06	1,164.06	1,654.00	489.94	70.4
26-51000-220	UTILITIES	6,707.84	6,707.84	24,240.00	17,532.16	27.7
26-51000-221	TELECOMMUNICATIONS	13,409.27	26,667.78	119,062.00	92,394.22	22.4
26-51000-225	COMPUTER SUPPORT SERVICES	.00	.00	3,500.00	3,500.00	.0
26-51000-226	BENEFIT ADMINISTRATIVE FEES	373.58	401.96	479.00	77.04	83.9
26-51000-230	MATERIALS & SUPPLIES	1,235.63	1,822.80	5,000.00	3,177.20	36.5
26-51000-236	LICENSING & MAINTENANCE	.00	123,680.06	180,868.00	57,187.94	68.4
26-51000-310	OFFICE SUPPLIES	.00	.00	1,800.00	1,800.00	.0
26-51000-311	POSTAGE	.00	400.00	500.00	100.00	80.0
26-51000-321	DUES & SUBSCRIPTIONS	.00	1,986.00	3,000.00	1,014.00	66.2
26-51000-322	TRAINING, SAFETY & CERTIFICATI	.00	199.00	3,000.00	2,801.00	6.6
26-51000-500	CONTINGENCY	.00	.00	14,112.00	14,112.00	.0
26-51000-510	GENERAL LIABILITY	.00	4,740.14	5,728.00	987.86	82.8
26-51000-513	WORKERS COMPENSATION	.00	2,395.52	2,400.00	4.48	99.8
26-51000-515	COMMERCIAL CRIME POLICY	.00	70.16	93.00	22.84	75.4
26-51000-516	PROPERTY INSURANCE	.00	3,162.11	3,730.00	567.89	84.8
	TOTAL PUBLIC SAFETY COMMUNIC	162,360.66	726,697.37	2,604,343.00	1,877,645.63	27.9
<u>TRANSFER TO OTHER FUND</u>						
26-59217-900	ADMINISTRATIVE/TRANSFER TO	.00	97,488.00	97,488.00	.00	100.0
	TOTAL TRANSFER TO OTHER FUND	.00	97,488.00	97,488.00	.00	100.0
	TOTAL FUND EXPENDITURES	162,360.66	824,185.37	2,701,831.00	1,877,645.63	30.5
	NET REVENUE OVER EXPENDITURES	108,035.93-	653,700.21	1.00-	-653,701.21	653700

VILLAGE OF BAYSIDE
REVENUES WITH COMPARISON TO BUDGET
FOR THE 4 MONTHS ENDING APRIL 30, 2021

LONG TERM FINANCIAL FUND

	PERIOD ACTUAL	YTD ACTUAL	BUDGET	UNEXPENDED	%
<u>TAXES</u>					
30-41100 PROPERTY TAXES	.00	792,089.00	792,089.00	.00	100.0
TOTAL TAXES	.00	792,089.00	792,089.00	.00	100.0
<u>LICENSES & PERMITS</u>					
30-44350 CELL TOWER FEES	2,027.33	8,042.48	23,031.00	14,988.52	34.9
TOTAL LICENSES & PERMITS	2,027.33	8,042.48	23,031.00	14,988.52	34.9
<u>INTERGOVERNMENT REVENUE</u>					
30-47111 FOX POINT REVENUE	.00	.00	14,705.00	14,705.00	.0
30-47115 B SERIES ADMIN FEE	.00	14,525.00	14,525.00	.00	100.0
TOTAL INTERGOVERNMENT REVENUE	.00	14,525.00	29,230.00	14,705.00	49.7
<u>MISCELLANEOUS REVENUE</u>					
30-48300 NSFD	.00	5,257.50	170,515.00	165,257.50	3.1
TOTAL MISCELLANEOUS REVENUE	.00	5,257.50	170,515.00	165,257.50	3.1
<u>OTHER FINANCING SOURCES</u>					
30-49100 PROCEEDS OF LONG-TERM DEBT	4,148,176.41	4,148,176.41	.00	-4,148,176.41	.0
30-49120 PROCEEDS OF PREMIUM	76,953.39	76,953.39	.00	-76,953.39	.0
30-49250 TRANSFER FROM STORMWATER FUN	.00	64,430.00	64,430.00	.00	100.0
TOTAL OTHER FINANCING SOURCES	4,225,129.80	4,289,559.80	64,430.00	-4,225,129.80	6657.7
TOTAL FUND REVENUE	4,227,157.13	5,109,473.78	1,079,295.00	-4,030,178.78	473.4

VILLAGE OF BAYSIDE
EXPENDITURES WITH COMPARISON TO BUDGET
FOR THE 4 MONTHS ENDING APRIL 30, 2021

LONG TERM FINANCIAL FUND

	PERIOD ACTUAL	YTD ACTUAL	BUDGET	UNEXPENDED	%
<u>DEBT</u>					
30-58100-215 MADACC	263.95	263.95	2,583.00	2,319.05	10.2
30-58100-226 BENEFIT ADMINISTRATIVE FEES	19,064.18	19,064.18	1,400.00	-17,664.18	1361.7
30-58100-595 PAYMENT TO ESCROW AGENT	57,251.37	57,251.37	.00	-57,251.37	.0
30-58100-611 NSFD STATION #5	.00	.00	160,000.00	160,000.00	.0
30-58100-612 FOX POINT/RIVER HILLS DISPATCH	2,352.50	2,352.50	34,833.00	32,480.50	6.8
30-58100-614 UNFUNDED LIABILITY PRINCIPAL	.00	26,000.00	26,000.00	.00	100.0
30-58100-616 2011 GENERAL OBLIGATION	975,200.00	975,200.00	76,250.00	-898,950.00	1279.0
30-58100-618 PRINCIPAL- 2014 BOND	.00	125,000.00	330,000.00	205,000.00	37.9
30-58100-619 2016 GENERAL OBLIGATION	.00	.00	125,000.00	125,000.00	.0
30-58100-620 2018 GENERAL OBLIGATION	.00	70,000.00	70,000.00	.00	100.0
30-58100-621 INTEREST ON BOND	12,866.90	45,244.40	196,465.00	151,220.60	23.0
30-58100-623 UNFUNDED LIABILITY INTEREST	.00	4,465.55	4,466.00	.45	100.0
TOTAL DEBT	<u>1,066,998.90</u>	<u>1,324,841.95</u>	<u>1,026,997.00</u>	<u>-297,844.95</u>	<u>129.0</u>
TOTAL FUND EXPENDITURES	<u>1,066,998.90</u>	<u>1,324,841.95</u>	<u>1,026,997.00</u>	<u>-297,844.95</u>	<u>129.0</u>
NET REVENUE OVER EXPENDITURES	<u><u>3,160,158.23</u></u>	<u><u>3,784,631.83</u></u>	<u><u>52,298.00</u></u>	<u><u>-3,732,333.83</u></u>	<u><u>7236.7</u></u>

VILLAGE OF BAYSIDE
 REVENUES WITH COMPARISON TO BUDGET
 FOR THE 4 MONTHS ENDING APRIL 30, 2021

POLICE CAPITAL

	PERIOD ACTUAL	YTD ACTUAL	BUDGET	UNEXPENDED	%
<u>TAXES</u>					
40-41100 PROPERTY TAXES	.00	71,480.00	71,480.00	.00	100.0
40-41130 FIRE & RESCUE PROPERTY TAXES	.00	28,711.00	28,711.00	.00	100.0
TOTAL TAXES	.00	100,191.00	100,191.00	.00	100.0
<u>INTERGOVERNMENTAL</u>					
40-43210 INTERGOVERNMENTAL GRANTS	.00	.00	750.00	750.00	.0
40-43215 POLICE REVENUE	.00	.00	10,500.00	10,500.00	.0
TOTAL INTERGOVERNMENTAL	.00	.00	11,250.00	11,250.00	.0
TOTAL FUND REVENUE	.00	100,191.00	111,441.00	11,250.00	89.9

VILLAGE OF BAYSIDE
EXPENDITURES WITH COMPARISON TO BUDGET
FOR THE 4 MONTHS ENDING APRIL 30, 2021

POLICE CAPITAL

	PERIOD ACTUAL	YTD ACTUAL	BUDGET	UNEXPENDED	%
<u>CAPITAL PROJECTS</u>					
40-91000-801 CAPITAL PROJECTS	39,871.00	68,851.00	75,711.00	6,860.00	90.9
40-91000-802 CAPITAL LEASE	.00	34,230.00	34,230.00	.00	100.0
40-91000-803 CAPITAL EQUIPMENT	.00	.00	1,500.00	1,500.00	.0
TOTAL CAPITAL PROJECTS	39,871.00	103,081.00	111,441.00	8,360.00	92.5
TOTAL FUND EXPENDITURES	39,871.00	103,081.00	111,441.00	8,360.00	92.5
NET REVENUE OVER EXPENDITURES	39,871.00-	2,890.00-	.00	2,890.00	.0

VILLAGE OF BAYSIDE
REVENUES WITH COMPARISON TO BUDGET
FOR THE 4 MONTHS ENDING APRIL 30, 2021

DEPARTMENT OF PUBLIC WORKS

	PERIOD ACTUAL	YTD ACTUAL	BUDGET	UNEXPENDED	%
<u>TAXES</u>					
41-41100	.00	50,000.00	50,000.00	.00	100.0
TOTAL TAXES	.00	50,000.00	50,000.00	.00	100.0
<u>INTERGOVERNMENTAL</u>					
41-43540	.00	37,548.00	37,548.00	.00	100.0
TOTAL INTERGOVERNMENTAL	.00	37,548.00	37,548.00	.00	100.0
<u>PUBLIC CHARGES FOR SERVICES</u>					
41-46320	1,491.29	5,013.99	.00	-5,013.99	.0
TOTAL PUBLIC CHARGES FOR SERVI	1,491.29	5,013.99	.00	-5,013.99	.0
<u>OTHER FINANCING SOURCES</u>					
41-49100	1,015,000.00	1,015,000.00	.00	-1,015,000.00	.0
41-49120	54,939.58	54,939.58	.00	-54,939.58	.0
TOTAL OTHER FINANCING SOURCES	1,069,939.58	1,069,939.58	.00	-1,069,939.58	.0
TOTAL FUND REVENUE	1,071,430.87	1,162,501.57	87,548.00	-1,074,953.57	1327.8

VILLAGE OF BAYSIDE
EXPENDITURES WITH COMPARISON TO BUDGET
FOR THE 4 MONTHS ENDING APRIL 30, 2021

DEPARTMENT OF PUBLIC WORKS

	PERIOD ACTUAL	YTD ACTUAL	BUDGET	UNEXPENDED	%	
<u>CAPITAL PROJECTS</u>						
41-91000-226	BENEFIT ADMINISTRATIVE FEES	25,545.51	25,545.51	.00	-25,545.51	.0
41-91000-801	CAPITAL PROJECTS	9,195.12	3,837.45	200,000.00	196,162.55	1.9
41-91000-803	CAPITAL EQUIPMENT	.00	.00	12,016.00	12,016.00	.0
	TOTAL CAPITAL PROJECTS	<u>34,740.63</u>	<u>29,382.96</u>	<u>212,016.00</u>	<u>182,633.04</u>	<u>13.9</u>
	TOTAL FUND EXPENDITURES	<u>34,740.63</u>	<u>29,382.96</u>	<u>212,016.00</u>	<u>182,633.04</u>	<u>13.9</u>
	NET REVENUE OVER EXPENDITURES	<u>1,036,690.24</u>	<u>1,133,118.61</u>	<u>124,468.00-</u>	<u>-1,257,586.61</u>	<u>910.4</u>

VILLAGE OF BAYSIDE
REVENUES WITH COMPARISON TO BUDGET
FOR THE 4 MONTHS ENDING APRIL 30, 2021

ADMIN SERVICES CAPITAL

	PERIOD ACTUAL	YTD ACTUAL	BUDGET	UNEXPENDED	%
<u>TAXES</u>					
42-41100 PROPERTY TAXES	.00	125,602.00	125,602.00	.00	100.0
TOTAL TAXES	.00	125,602.00	125,602.00	.00	100.0
<u>OTHER FINANCING SOURCES</u>					
42-49210 TRANSFER FROM GENERAL FUND	.00	46,000.00	46,000.00	.00	100.0
TOTAL OTHER FINANCING SOURCES	.00	46,000.00	46,000.00	.00	100.0
TOTAL FUND REVENUE	.00	171,602.00	171,602.00	.00	100.0

VILLAGE OF BAYSIDE
EXPENDITURES WITH COMPARISON TO BUDGET
FOR THE 4 MONTHS ENDING APRIL 30, 2021

ADMIN SERVICES CAPITAL

	PERIOD ACTUAL	YTD ACTUAL	BUDGET	UNEXPENDED	%
<u>CAPITAL PROJECTS</u>					
42-91000-519 GASB 45 OBLIGATIONS	.00	.00	136,717.00	136,717.00	.0
42-91000-801 CAPITAL PROJECTS	4,896.00	4,896.00	29,896.00	25,000.00	16.4
42-91000-803 CAPITAL EQUIPMENT	.00	.00	75,000.00	75,000.00	.0
TOTAL CAPITAL PROJECTS	4,896.00	4,896.00	241,613.00	236,717.00	2.0
TOTAL FUND EXPENDITURES	4,896.00	4,896.00	241,613.00	236,717.00	2.0
NET REVENUE OVER EXPENDITURES	4,896.00-	166,706.00	70,011.00-	-236,717.00	238.1

VILLAGE OF BAYSIDE
 REVENUES WITH COMPARISON TO BUDGET
 FOR THE 4 MONTHS ENDING APRIL 30, 2021

PUBLIC SAFETY COMM CAPITAL

	PERIOD ACTUAL	YTD ACTUAL	BUDGET	UNEXPENDED	%
<u>TAXES</u>					
46-41100 PROPERTY TAXES	.00	21,962.00	21,962.00	.00	100.0
TOTAL TAXES	.00	21,962.00	21,962.00	.00	100.0
<u>INTERGOVERNMENTAL REVENUE</u>					
46-47110 CONTRACT REVENUE	.00	153,735.07	153,735.00	-.07	100.0
TOTAL INTERGOVERNMENTAL REVE	.00	153,735.07	153,735.00	-.07	100.0
TOTAL FUND REVENUE	.00	175,697.07	175,697.00	-.07	100.0

VILLAGE OF BAYSIDE
EXPENDITURES WITH COMPARISON TO BUDGET
FOR THE 4 MONTHS ENDING APRIL 30, 2021

PUBLIC SAFETY COMM CAPITAL

	PERIOD ACTUAL	YTD ACTUAL	BUDGET	UNEXPENDED	%
<u>DEPARTMENT 91000</u>					
46-91000-801 CAPITAL PROJECTS	112,992.51	112,992.51	155,211.51	42,219.00	72.8
46-91000-803 CAPITAL EQUIPMENT	.00	.00	51,000.00	51,000.00	.0
TOTAL DEPARTMENT 91000	<u>112,992.51</u>	<u>112,992.51</u>	<u>206,211.51</u>	<u>93,219.00</u>	<u>54.8</u>
TOTAL FUND EXPENDITURES	<u>112,992.51</u>	<u>112,992.51</u>	<u>206,211.51</u>	<u>93,219.00</u>	<u>54.8</u>
NET REVENUE OVER EXPENDITURES	<u>112,992.51-</u>	<u>62,704.56</u>	<u>30,514.51-</u>	<u>-93,219.07</u>	<u>205.5</u>

VILLAGE OF BAYSIDE
 REVENUES WITH COMPARISON TO BUDGET
 FOR THE 4 MONTHS ENDING APRIL 30, 2021

LIBRARY FUND

	PERIOD ACTUAL	YTD ACTUAL	BUDGET	UNEXPENDED	%
<u>LIBRARY FUND</u>					
50-47400 JOINT LIBRARY RECEIVABLES	197,587.66	395,142.82	953,032.00	557,889.18	41.5
50-47410 LIBRARY COPY FEES	252.32	366.22	10,000.00	9,633.78	3.7
50-47420 LIBRARY FINES	2,204.10	5,195.49	27,000.00	21,804.51	19.2
50-47430 NET LENDER REVENUE	.00	169.00	175.00	6.00	96.6
50-47440 MISC REVENUE	.00	32.50	.00	-32.50	.0
50-47500 DONATIONS	.00	2.48	250.00	247.52	1.0
TOTAL LIBRARY FUND	200,044.08	400,908.51	990,457.00	589,548.49	40.5
TOTAL FUND REVENUE	200,044.08	400,908.51	990,457.00	589,548.49	40.5

VILLAGE OF BAYSIDE
EXPENDITURES WITH COMPARISON TO BUDGET
FOR THE 4 MONTHS ENDING APRIL 30, 2021

LIBRARY FUND

	PERIOD ACTUAL	YTD ACTUAL	BUDGET	UNEXPENDED	%
50-50230-900 WIS RETIREMENT UNFUNDED PAYME	.00	.00	13,571.00	13,571.00	.0
TOTAL DEPARTMENT 50230	.00	.00	13,571.00	13,571.00	.0

GENERAL LIBRARY

50-61000-110 LIBRARY DIRECTOR SALARY	5,769.60	22,058.18	84,068.00	62,009.82	26.2
50-61000-120 SALARIES-OTHER LIBRARY STAFF	27,214.98	110,964.80	529,655.00	418,690.20	21.0
50-61000-150 WISCONSIN RETIREMENT	1,236.38	5,024.22	26,594.00	21,569.78	18.9
50-61000-151 SOCIAL SECURITY	2,433.39	10,418.38	46,950.00	36,531.62	22.2
50-61000-152 LIFE INSURANCE	2.05	24.25	120.00	95.75	20.2
50-61000-153 HEALTH INSURANCE	4,410.07	24,184.61	100,476.00	76,291.39	24.1
50-61000-154 DENTAL INSURANCE	37.75	234.04	.00	-234.04	.0
50-61000-156 UNEMPLOYMENT	.00	.00	4,000.00	4,000.00	.0
50-61000-210 CONTRACTUAL SERVICES	.00	.00	19,521.00	19,521.00	.0
50-61000-218 LEGAL FEES	.00	.00	2,500.00	2,500.00	.0
50-61000-221 ELECTRIC	2,693.39	11,684.75	33,530.00	21,845.25	34.9
50-61000-222 TELEPHONE	1,116.78	1,506.72	3,450.00	1,943.28	43.7
50-61000-223 WATER/SEWER	400.70	566.40	2,850.00	2,283.60	19.9
50-61000-227 SYSTEM EXPENSE	99.13	43,706.13	46,357.00	2,650.87	94.3
50-61000-230 MAINTENANCE	3,678.00	5,046.75	36,500.00	31,453.25	13.8
50-61000-233 EQUIPMENT MAINTENANCE	331.34	3,942.62	10,634.00	6,691.38	37.1
50-61000-310 SUPPLIES	2,860.47	5,415.04	18,800.00	13,384.96	28.8
50-61000-311 POSTAGE	52.73	52.73	600.00	547.27	8.8
50-61000-321 DUES-EDUCATIONAL	114.51	114.51	1,200.00	1,085.49	9.5
50-61000-322 STAFF TRAINING	332.93	663.93	3,390.00	2,726.07	19.6
50-61000-323 PROMO & ADVERTISING	.00	34.75	1,350.00	1,315.25	2.6
50-61000-345 MILEAGE	.00	.00	700.00	700.00	.0
50-61000-399 BANK SERVICE FEE	.00	.00	100.00	100.00	.0
50-61000-501 SALES TAX EXPENSE	.00	169.11	500.00	330.89	33.8
50-61000-510 INSURANCE AND BONDING	.00	.00	1,400.00	1,400.00	.0
50-61000-513 WORKERS COMP INSURANCE	.00	247.94	1,350.00	1,102.06	18.4
50-61000-535 LEASE/CONDO FEES	.00	.00	23,139.00	23,139.00	.0
50-61000-811 REFERENCE-SERIALS	89.36	771.36	8,985.00	8,213.64	8.6
50-61000-812 ADULT BOOKS	2,971.90	3,090.07	21,000.00	17,909.93	14.7
50-61000-813 JUVENILE BOOKS	3,361.58	6,885.13	16,500.00	9,614.87	41.7
50-61000-815 NONPRINT MEDIA	620.26	1,470.01	8,200.00	6,729.99	17.9
50-61000-830 ADULT PROGRAMS	30.99	130.99	2,000.00	1,869.01	6.6
TOTAL GENERAL LIBRARY	59,858.29	258,407.42	1,056,419.00	798,011.58	24.5
TOTAL FUND EXPENDITURES	59,858.29	258,407.42	1,069,990.00	811,582.58	24.2
NET REVENUE OVER EXPENDITURES	140,185.79	142,501.09	79,533.00-	-222,034.09	179.2

Village of Bayside Community Impact Report April 2021

PUBLIC MEETINGS/EVENTS



15
↑ **66%**

BOND RATING



Aa

ACCREDITATION



Police
Fire
Dispatch

POLICE VISIBILITY



37,098
↓ **6%**

MYBLUE CONTACTS



39
↑ **105%**

GFOA EXCELLENCE



Since
2008

DISPATCH TIME



30 secs
↓ **29%**

DISPATCH CALLS



33,717
↑ **7%**

GFOA CAFR



Since
2011

GRANT \$ AWARDED

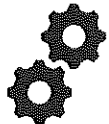

\$75,184.97
↓ **74%**

FUND BALANCE



29%
→ **0%**

ICMA CPM EXCELLENCE



Since
2012

GARBAGE TONS YTD



398
↑ **2%**

RECYCLING TONS YTD



159
↓ **4%**

TREE CITY USA



Since
2008

DIVERSION RATE



28%
↓ **2%**

ACCESS BAYSIDE REQUESTS



732
↑ **23%**

BIRD CITY USA



Since
2010

WEB SITE VISITS



16,455
↓ **5%**

SOCIAL MEDIA REACH



58,317
↑ **12%**

BUZZ OPEN RATE



53%
↓ **15%**

*Metrics compared to 2020 YTD

**VILLAGE OF BAYSIDE
MILWAUKEE COUNTY, WISCONSIN**

RAZE OR REPAIR ORDER

TO: Milton and Sarah Hwang
550 East Glencoe Place
Bayside, WI 53217

RE: 550 East Glencoe Place
Tax Key No. 021-0147-000

PLEASE TAKE NOTICE that the Village of Bayside Building Inspector has determined that the structure located at 550 East Glencoe Place, Village of Bayside, Wisconsin, also known by Tax Key No. 021-0147-000 is out of repair and consequently dangerous, unsafe and otherwise unfit for use or occupation until necessary repairs have been made. The owner of this property has 30 days from service of this Order in which to repair or raze the structure. In order to satisfy this Raze or Repair Order, repairs to be made shall include the following:

- Repair to bring structure into compliance with Village Code.

This Order is made pursuant to the provisions of Section 66.0413 Wis. Stats. The failure to comply with the terms of this Order shall result in the Village of Bayside seeking remedies available under the statutory section cited including the razing of the offending structure by Court Order.

Dated this _____ day of May, 2021.

Tod Doeblen
Village of Bayside Building Inspector



Bayside Communications Center April 2021

Highlights / Accomplishments

- BCC is proud to welcome the addition of Paige Moss to the training team. Paige will be completing her Certified Training Officer Certification and will be assisting in training new hires.
- We are currently recruiting for the position of dispatcher in the Communications Center. We have narrowed down the candidates and will be conducting final interviews over the next few weeks.
- Staff are completing training on restricting radio channels during large scale incidents and are working with North Shore Fire on training topics to enhance fire operations and awareness in the center.
- BCC Supervisor Reed is working with Stormonth School to provide 911 education at an upcoming safety fair in conjunction with Fox Point Police.

PHONE CALLS



911 CALLS



CALL REVIEWS



POLICE CALLS



FIRE CALLS

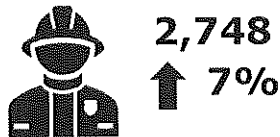

ALS CALLS



REQUEST FOR POLICE



TRAFFIC STOPS



911 HANG UPS

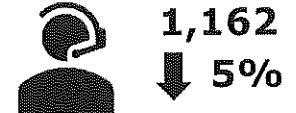

ANSWER TIME



DISPATCH TIME

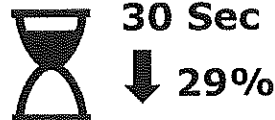

ACCREDITATION





Police Department April 2021

Highlights / Accomplishments

- As part of the new weekly training program, the North Shore Fire Department presented a roll call workshop on how police officers can aid firefighters in response to fires.
- The Department received \$5,000 for high visibility speed enforcement from June 1 through September 15, 2021. This was \$1,000 less than requested.
- Body armor for three officers is being ordered. Using a longstanding grant from the federal government, the Village will pay 50% of the \$800 cost. Funds are set aside each year to meet the match requirement.
- Declining citation revenue, being examined by Lieutenant Miller, appears to be a result of lowered enforcement by police officers during the worst of the pandemic.
- The successor agreement between the Village and the Teamster Union (Police Officers) has been ratified by the police officers. It will be presented to the Village Board at a near date for approval.

REPORTS WRITTEN



123
↓ 42%

CALLS FOR SERVICE



1,774
↓ 5%

ASSIST AGENCIES



111
↑ 56%

TRAFFIC STOPS

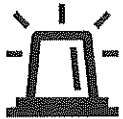

718
↑ 16%

CITATIONS



297
↑ 7%

WARNINGS



439
↑ 15%

MILES PATROLLED



37,098
↓ 6%

CRIME PREVENTION



47
↓ 45%

ARRESTS



53
↓ 29%

CODES ENFORCED



80
↑ 150%

ORDINANCES



25
↑ 19%

ACCREDITATION



*Metric compared to 2020 YTD

The Bayside Mediation Center is a service for people and businesses in Bayside. There is **NO CHARGE** for the service.

Mediation offers the opportunity for people to find their own solutions with the aid of a trained mediator. Services are available for adults as well as young people. Most mediations are conducted at the Bayside Village Hall, as a matter of convenience.

QUICK: Mediations can usually be scheduled within two weeks of the referral as opposed to the judicial system, which may take many months.

CONFIDENTIAL: The mediation takes place in a private, neutral setting.

CONVENIENT: Mediations can be arranged during the day or after business hours.

CALL 414-206-3916

VILLAGE OF BAYSIDE
9075 Regent Road
Bayside - WI - 53217

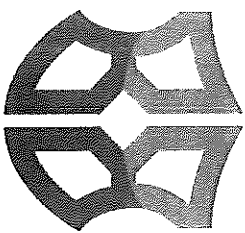

BUILDING THE BOND
ONE STREET AT A TIME

www.baysidewi.gov/connect-with-myblue

Bayside
MEDIATION
CENTER

Helping People
Resolve Conflict



9075 REGENT ROAD
BAYSIDE WISCONSIN 53217
PHONE: 414-206-3916

What is Mediation?

Part of the mission to create a safe and friendly environment is to offer mediation to solve ongoing issues.

The Bayside mediation service is a process that assists people in resolving conflicts or disputes. The mediation session offers people the opportunity to create their own mutually agreeable solutions with the assistance of a trained, impartial third party - a mediator. The mediator doesn't make decisions for the people involved or determine who is right or wrong. Mediation is not a court hearing or a counseling session.

Mediation sessions are casual, yet structured to help clarify the issues and move towards agreement. Parties are given the opportunity to speak without interruption. If an agreement is reached, it may be signed by the parties. Before participating in a mediation session, the parties should think about possible solutions to the problem.

Types of Disputes That Can Be Resolved

Community Problems

Noise, pets, neighbors, parking, boundary disputes

Juvenile Disputes

Conflicts between youth, youth and adults, and schools

Family Disputes

Family problems, domestic issues such as roommates and friends

Landlord - Tenant issues

Security deposit, repairs, damages



Accessing Mediation Services

To request mediation services, or for more information, call:

414-206-3916

A case manager will call to discuss your situation and explain the process in detail. The Center staff will contact the others involved in the dispute and request their participation in mediation.

Mediation sessions are scheduled at times that are convenient for all participants. Evening appointments are available.

Most disputes can be resolved in just one session!

Mediation is voluntary and confidential.

Mediation is free!

Anyone can call for this service.



Department of Public Works April 2021

Highlights / Accomplishments

- The crew completed the dead tree removal project in the right-of-way. The crew removed 157 trees total. Stump grinding and restoration is planned to follow.
- The Department cleaned and readied the Ellsworth Park pavilion and well for opening to the public.
- The crew hosted the Spring Clean Up Day in the DPW parking lot. 336 residents participated in the event.
- The crew started shoulder repair in many spots of the Village. Shoulder work will continue throughout the summer.
- Repairs were made to the Ellsworth Park playground structure that were found on the Spring inspection.
- The Operations Superintendent and DPW technicians participated in multiple training sessions in April. Playground inspection and work zone safety topics were covered.

GARBAGE TONS YTD

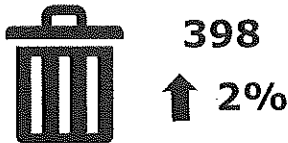

RECYCLING TONS YTD



DIVERSION RATE



YARD WASTE
COLLECTION STOPS



YARDS OF YARD
WASTE COLLECTED

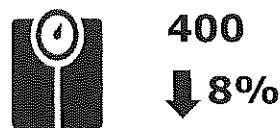

RECYCLING DAY
PARTICIPANTS

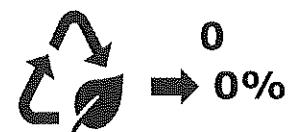

SEE CLICK FIX
REQUESTS CLOSED



MULCH DELIVERIES



YARDS OF MULCH
DELIVERED



SEWER MAIN CLEANED

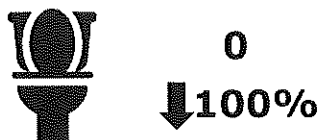

CULVERTS REPLACED





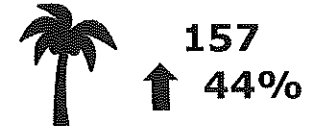

TREES REMOVED



*Metrics compared to 2020 YTD

Highlights / Accomplishments

- Accurate Appraisal was in the Village working to complete the 2021 assessment data. It is anticipated that chance notices will be mailed on May 20.
- Tax Collection Continues:
 - * 2020 Ozaukee County YTD: 84.19% (2019 YTD: 83.03%)
 - * 2020 Milwaukee County YTD: 85.49% (2019 YTD: 84.79%)
- Liquor License applications were received from the various businesses and published in the newspaper. An application has not yet been received from Los Paisa and a reminder letter has been sent to the owner of the business.
- The first quarter commercial sewer and stormwater invoices totaling \$63,453.83 were sent out.
- There was a total of \$109,484.95 in delinquent property tax notices sent out to 28 property owners. This time last year there was a total of \$225,275.96.

	GENERAL GOVERNMENT	SANITARY SEWER	STORM WATER	DISPATCH CENTER	NORTH SHORE LIBRARY
					
R E X P V P	67%/41%	92%/19%	126%/35%	55%/31%	57%/25%

PERCENTAGE OF 2021 BUDGET SPENT

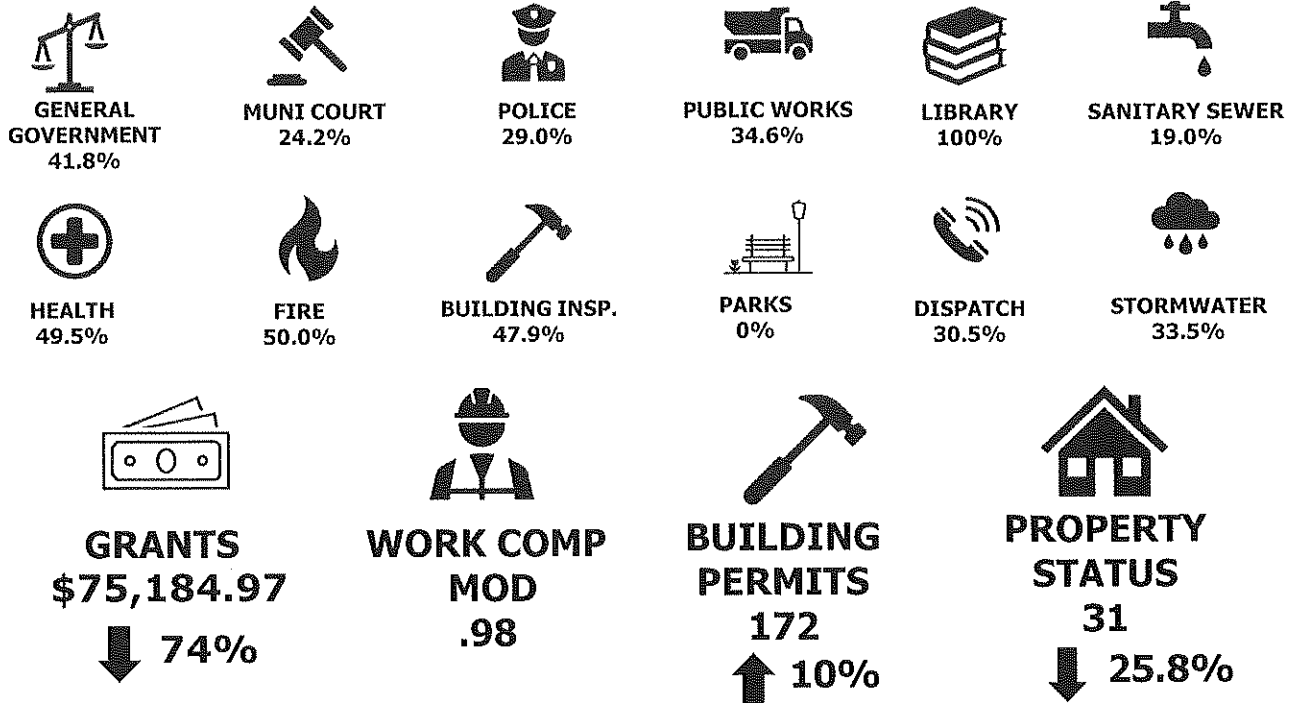

*Metrics compared to 2020 YTD

**STATE OF WISCONSIN
MILWAUKEE AND OZAUKEE COUNTIES
VILLAGE OF BAYSIDE**

RESOLUTION NO: 21-___

**A Resolution to Revoke the Declaration of Public Health Emergency
in Response to the COVID-19 Corona Virus**

The Village Board of the Village of Bayside, Milwaukee and Ozaukee Counties, Wisconsin, does ordain as follows:

WHEREAS, on March 17, 2020, the Village Board declared a public health emergency in response to the COVID-19 Corona Virus in the form of Resolution No. 20-3; and

WHEREAS, pursuant to Section 323.11 Wis. Stats., the Village Board declared the public health emergency for sixty days from March 17th or until revoked or extended by subsequent Village Board resolution; and

WHEREAS, pursuant to Section 323.11 Wis. Stats., the period of such declaration of public health emergency is to be limited to the time during which the public emergency conditions exist or are likely to exist; and

WHEREAS, on May 13, 2020, by Resolution No. 20-11, the Village Board extended the declaration of public health emergency to June 25, 2020; and

WHEREAS, on June 18, 2020, by Resolution No. 20-14, the Village Board extended the declaration of public health emergency to October 1, 2020; and

WHEREAS, on August 20, 2020, by Resolution No. 20-17, the Village Board extended the declaration of public emergency until such time as the public emergency conditions no longer exist or until such time as said resolution is revoked or extended by subsequent resolution of the Village Board; and

WHEREAS, said public health emergency conditions no longer exist;

NOW THEREFORE, BE IT RESOLVED, that Resolution No. 20-3 declaring a public health emergency in the Village of Bayside is hereby revoked, effective June 1, 2021.

PASSED AND ADOPTED by the Village Board of Trustees of the Village of Bayside this twentieth day of May, 2021.

VILLAGE OF BAYSIDE

Eido M. Walny, Village President

Attest

Lynn A. Galyardt, Administrative Services
Director/Village Clerk/Treasurer

**STATE OF WISCONSIN
MILWAUKEE AND OZAUKEE COUNTIES
VILLAGE OF BAYSIDE**

RESOLUTION NO: 21-___

**A Resolution to Authorize the Sale and Consumption of Fermented Malt Beverages
In Village Parks Under Section 125.06(6) Wis. Stats.**

The Village Board of the Village of Bayside, Milwaukee and Ozaukee Counties, Wisconsin, does ordain as follows:

WHEREAS, the Village Board is authorized to approve the sale and consumption of fermented malt beverages in public parks pursuant to Section 125.06(6) Wis. Stats.; and

WHEREAS, the Village Board desires to permit the operation of an outdoor beer garden in Village public parks for the entertainment of the public,

NOW THEREFORE, BE IT RESOLVED, that the Village Board of the Village of Bayside, pursuant to Section 125.06(6) Wis. Stats, does hereby authorize the sale by Village employees and officials, and the public consumption, of fermented malt beverages in Village public parks on the following dates (subject to any rescheduling for rain dates): May 21, 2021; June 5, 2021; July 17, 2021; August 14, 2021; and September 25, 2021.

PASSED AND ADOPTED by the Village Board of Trustees of the Village of Bayside this twentieth day of May, 2021.

VILLAGE OF BAYSIDE

Eido M. Walny, Village President

Attest

Lynn A. Galyardt, Administrative Services
Director/Village Clerk/Treasurer

Ashtyn Damas
Sales, WI
641 West Main Street
Apt. 264
Sun Prairie, WI 53590
(cell) 608-438-5317
bolandrecwi@mediacombb.net



www.bolandrecreation.com

2347 Oak Park Road
Marshalltown, IA 50158
iowaparkplace@mchsi.com
1-800-798-7589

Ellsworth Park
Bayside, WI
April 29, 2021

Option 1: Cost includes all equipment and freight

\$81,402

**Benches and table not included. They are where the ones you already have are so you can see how it would look.

Prepared by: Ashtyn Damas

Prices are good until April 20, 2021

Prices include delivery to your job site

*Prices **DO NOT** include sales tax, if applicable*

Payment for materials is due by 30 days after delivery.

Payment for installation services is due by 15 days after completion of work.

Boland Recreation reserves the right to charge a 1.5% fee on past due invoices.

Delivery time is four-six weeks after the order has been placed, unless agreed upon differently

NOTE: Boland Recreation, Inc. is NOT RESPONSIBLE for unloading of equipment, storage, permits, fees, ground preparation, pea gravel, borders, disposal of trash, sales tax, or anything in addition to what is listed above.

Ellsworth Park
Bayside, WI CD226025

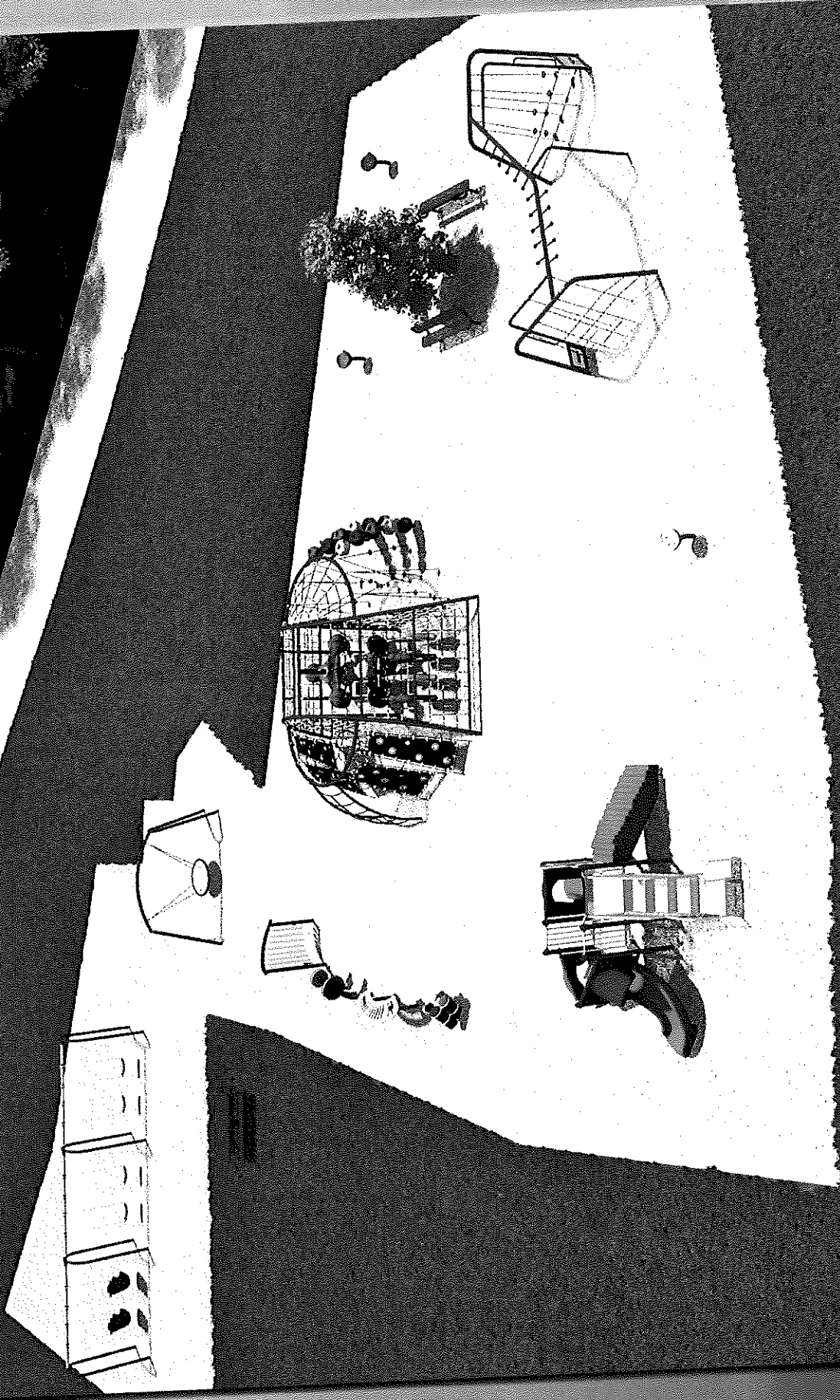

Miracle

www.miracle-recreation.com

Ellsworth Park
Bayside, WI CD226025

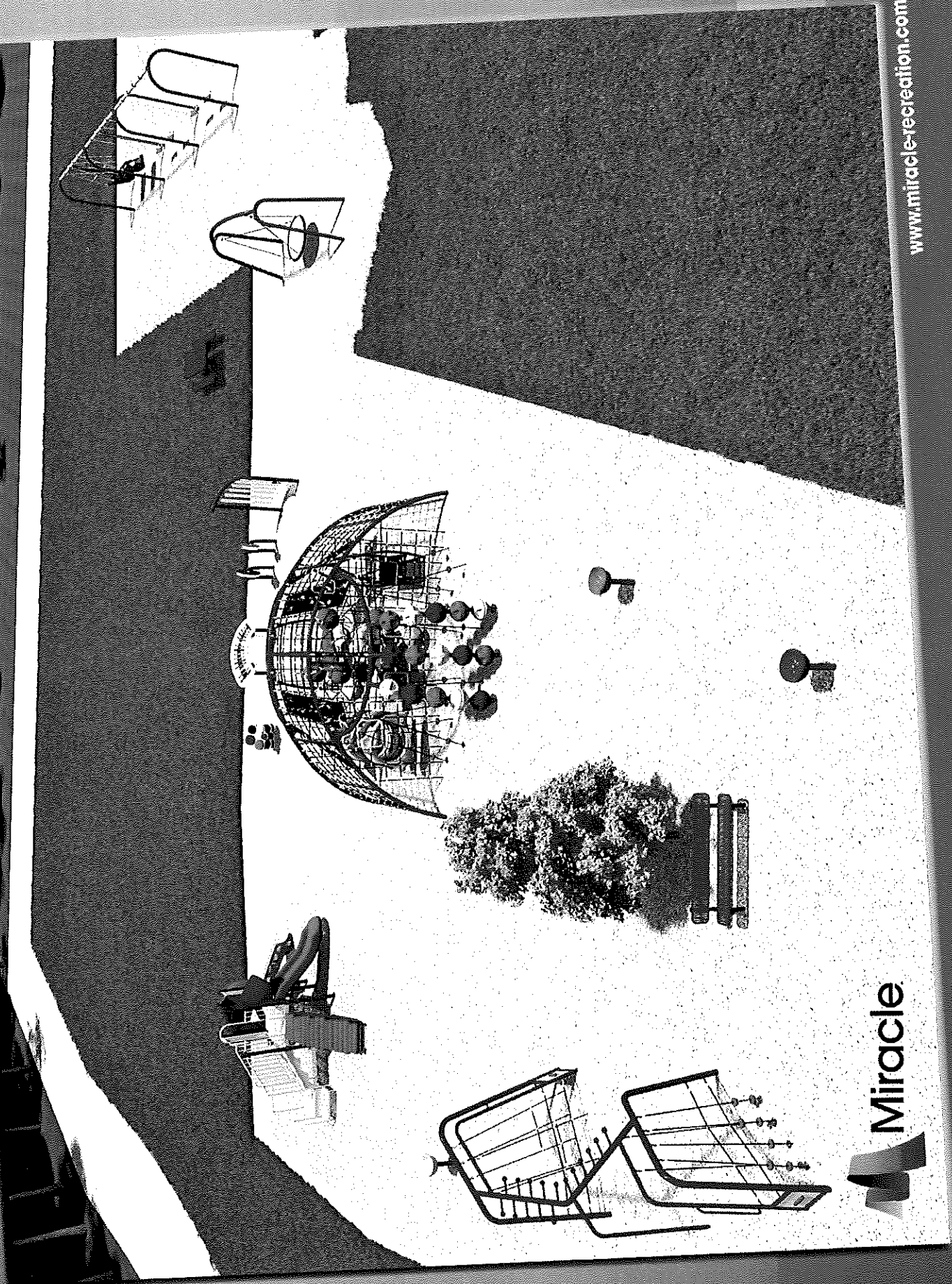

 **Miracle**

www.miracle-recreation.com

Ellsworth Park
Bayside, WI CD226025

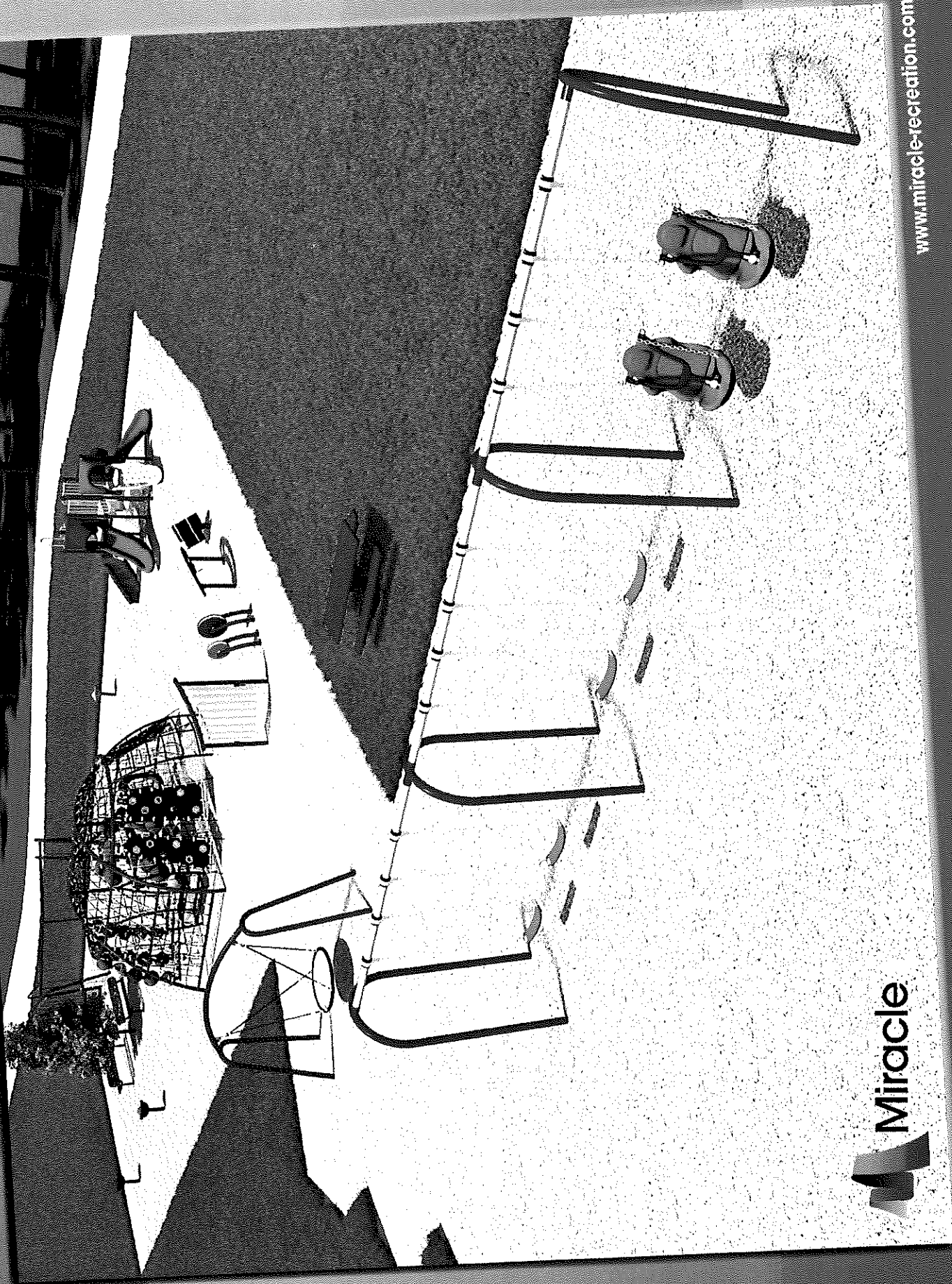

 Miracle

www.miracle-recreation.com

Ellsworth Park
Bayside, WI CD226025

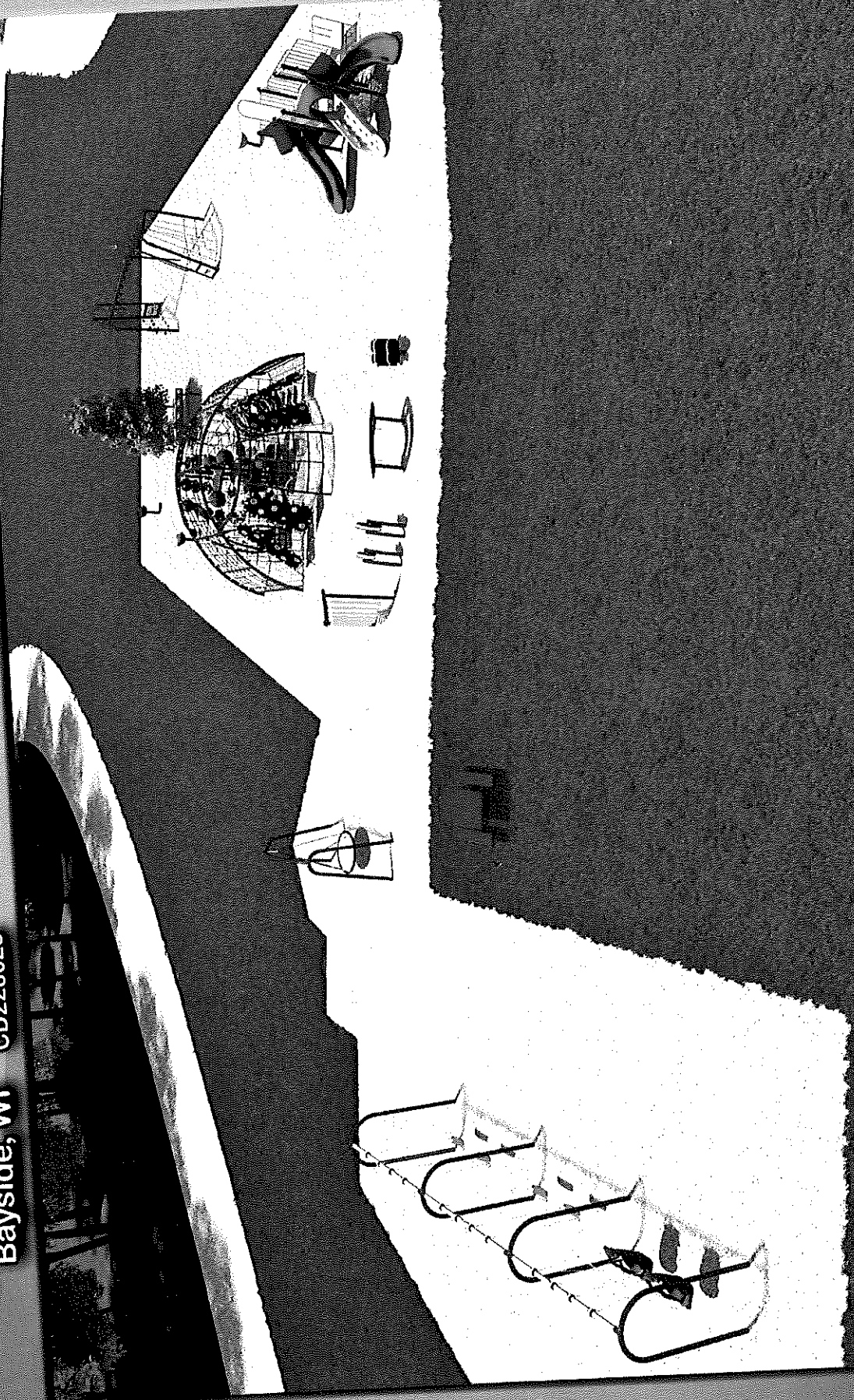

Miracle

www.miracle-recreation.com

Ellsworth Park
Bayside, WI CD226025

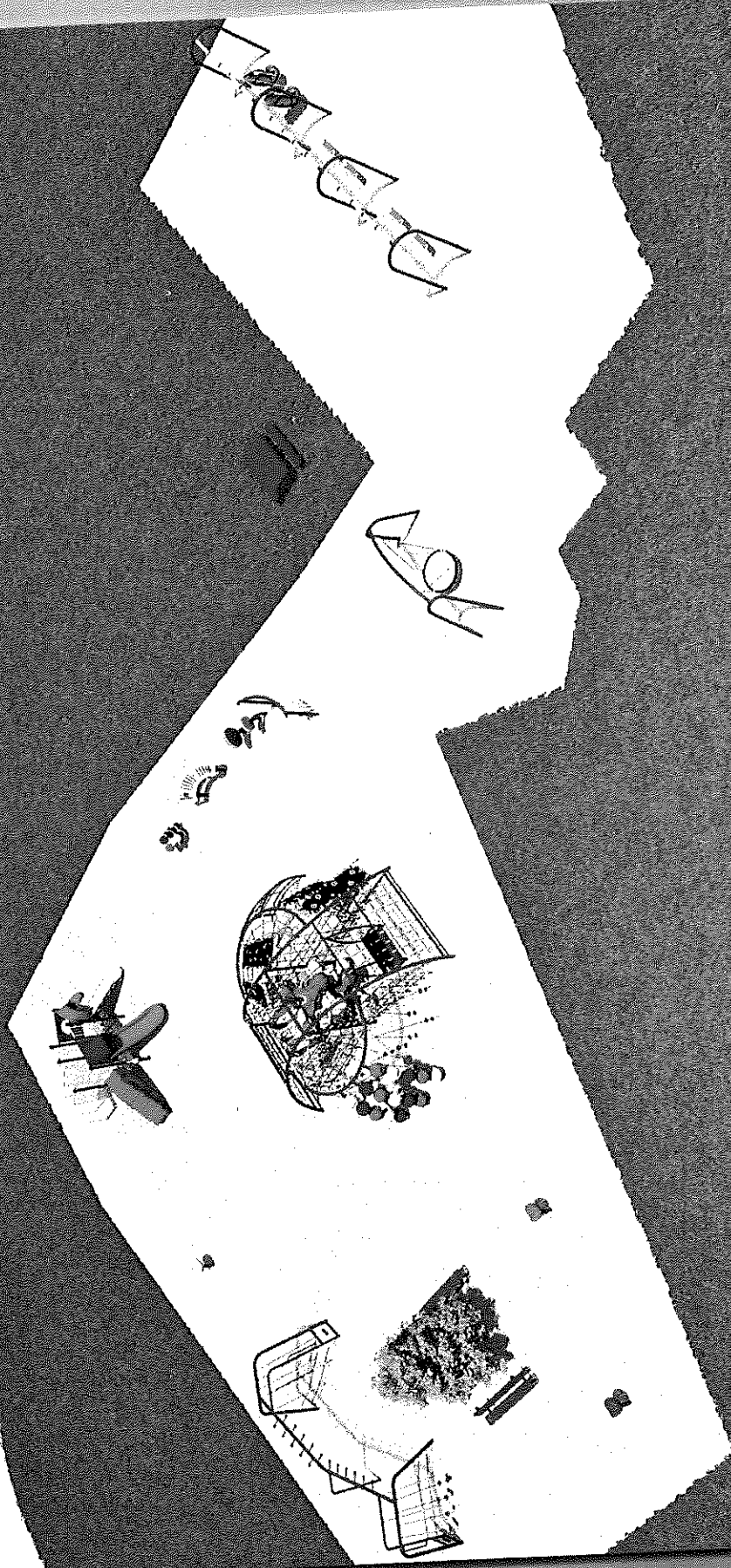

Miracle

www.miracle-recreation.com



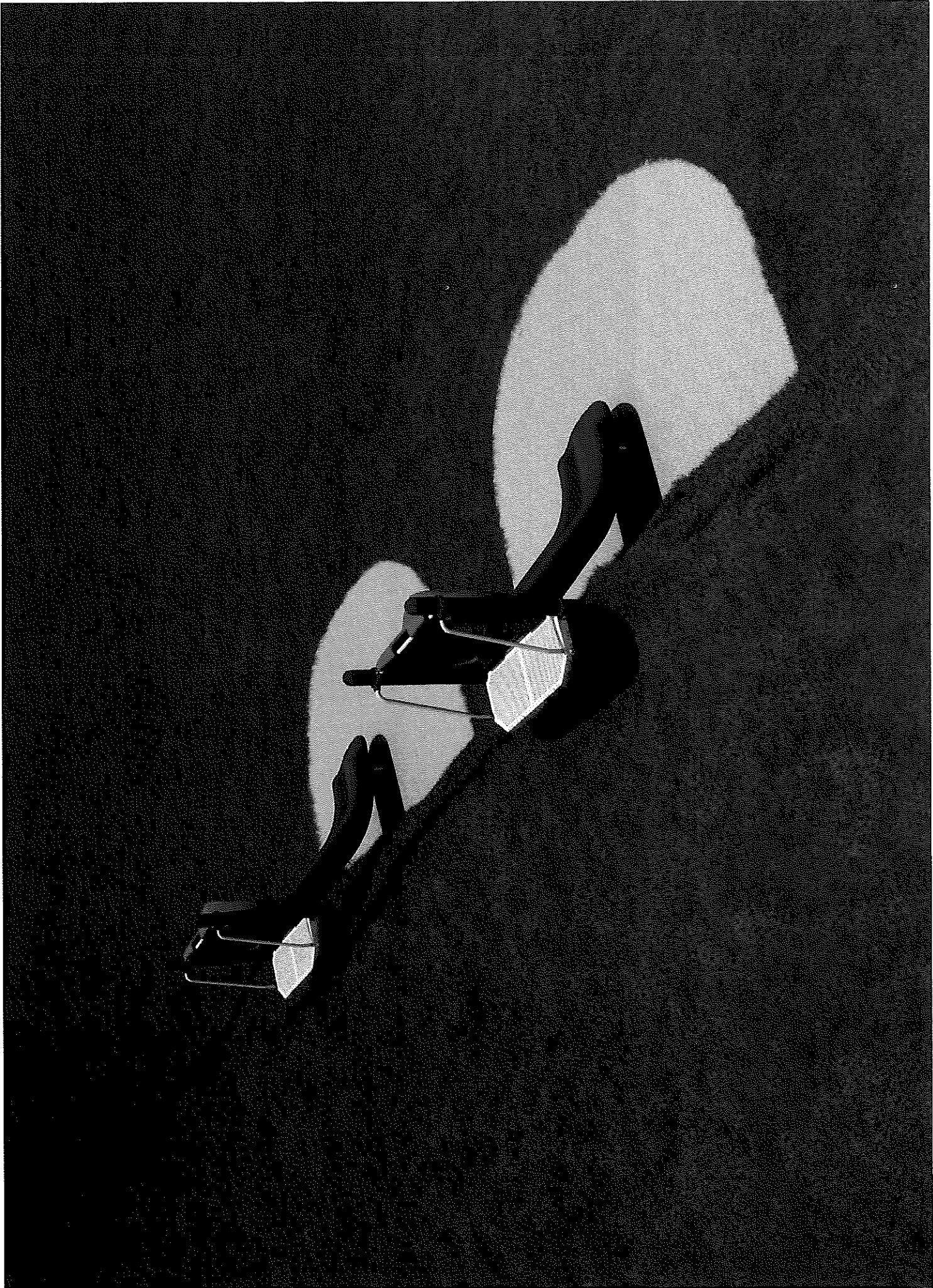

ELLSWORTH PARK BAYSIDE, WI

2-12 PLAY AREA

ELEVATED PLAY ACTIVITIES - TOTAL	4
ELEVATED PLAY ACTIVITIES ACCESSIBLE BY TRANSFER	2
ELEVATED PLAY ACTIVITIES ACCESSIBLE BY RAMP	0
GROUND LEVEL ACTIVITY TYPE	0
GROUND LEVEL ACTIVITY QUANTITY	21

AREA: 7023 sq ft
PERIMETER: 468 ft

The information provided is for estimation purposes only.

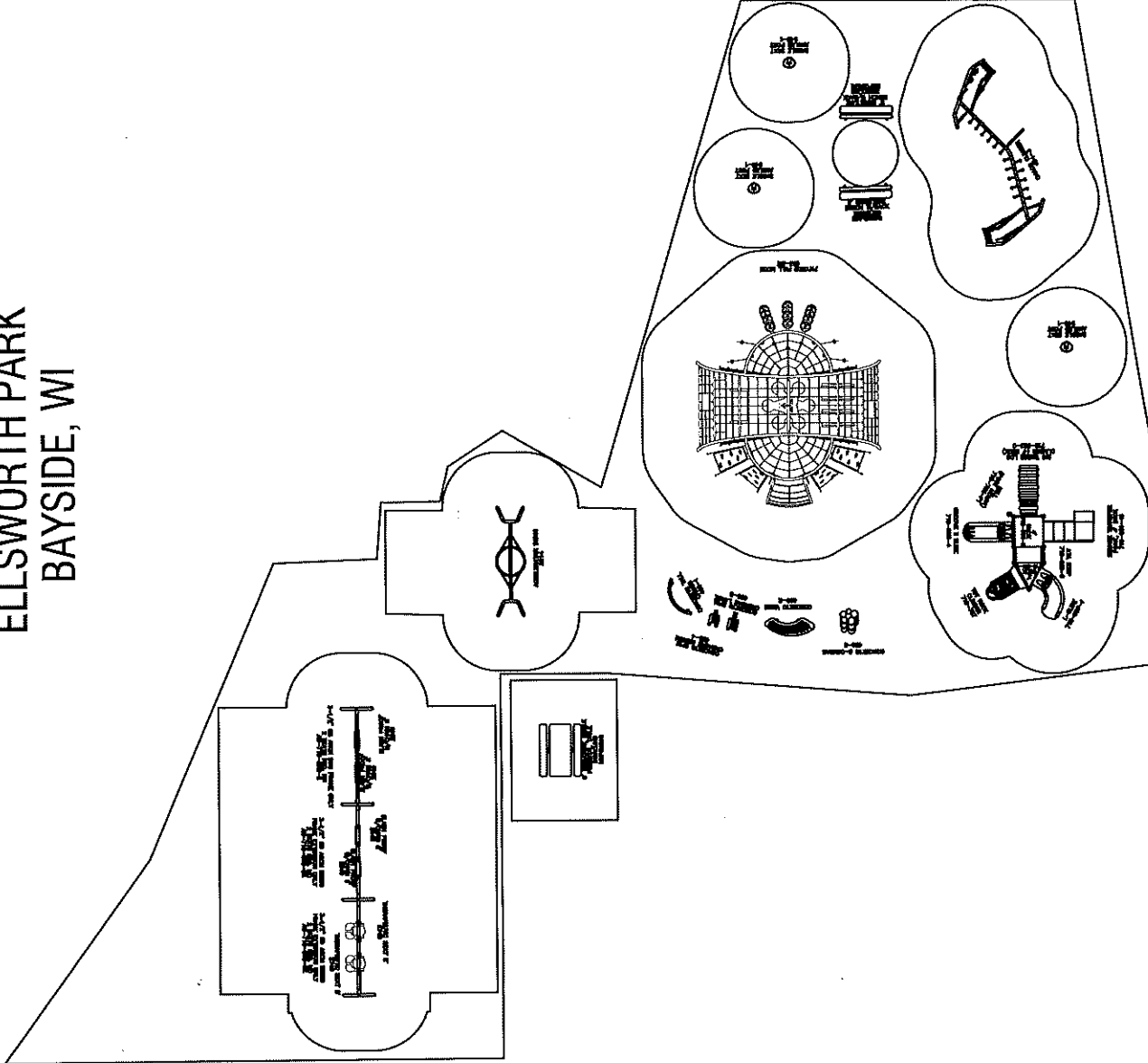

To verify product certification, visit www.ipema.org

To promote safe and proper equipment use by children, Miracle recommends the installation of either a Miracle safety sign or other appropriate safety signage near each play system's main entry point(s) to inform parents and supervisors of the age appropriateness of the playsystem and general rules for safe play.

THE PLAY COMPONENTS IDENTIFIED IN THIS PLAN ARE IPEMA CERTIFIED. THE USE AND LAYOUT OF THESE COMPONENTS CONFORM TO THE REQUIREMENTS OF ASTM F1487.

AN ENERGY ABSORBING PROTECTIVE SURFACE IS REQUIRED UNDER & AROUND ALL PLAY SYSTEMS.

CD226025	✓	COMPLIES TO CPSC
GROUND SPACE: 109' X 88' PROTECTIVE AREA: 121' X 109'	✓	COMPLIES TO ASTM
	✓	COMPLIES TO ADA

DESIGNED FOR AGES 2-12

ADDITIONAL GROUND LEVEL ACCESSIBLE ITEMS NEEDED FOR ADA COMPLIANCE
TYPE: 0 QUANTITY: 0

SCALE: 1" = 20'-0"

DATE: 5/3/2021

TRIP





1279 Hazelton-Etna Road SW
 Pataskala, OH 43062
 614-855-3790
 www.midstatesrecreation.com

QUOTATION

Sold To	WI- Bayside, Village of 9075 N Regent Rd Bayside , WI, 53217 United States	Ship To	WI- Bayside, Village of 600 E Ellsworth Ln Bayside, WI, 53217 United States
----------------	---	----------------	--

Date	Quote #	Terms	Rep	Project	Ship Contact
2021-04-29	QTN-07339 Valid Until 05-29-2021		Melanie Breunig	2021 03 Ellsworth Park - WI- Bayside, Village Of	Leah Hofer (414) 206-3914

Item Code	Description	Qty	Rate	Amount
ExoFit Outdoor Fitness	ExoFit Outdoor Fitness: ExoPod	1.0 Unit	\$ 17,599.00	\$ 17,599.00
Freight	Shipping Charges are estimated and are subject to actual shipping charges incurred at time of shipment.	1.0 Unit	\$ 1,944.00	\$ 1,944.00
Customer Discount	Customer Discounts	1.0 Unit	\$ -977.15	\$ -977.15

Subtotal	\$ 18,565.85
WI - Milwaukee 5.6%	\$ 0.00
Total	\$ 18,565.85

Signature _____
 (Approval)

Printed Name _____

Title _____

Date _____



Specifications and Installation

ExoCage XO-CAGE-2

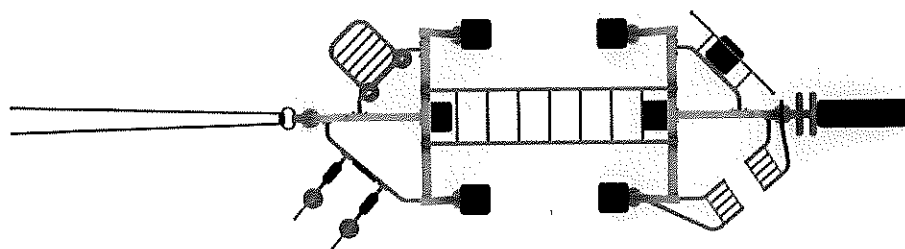
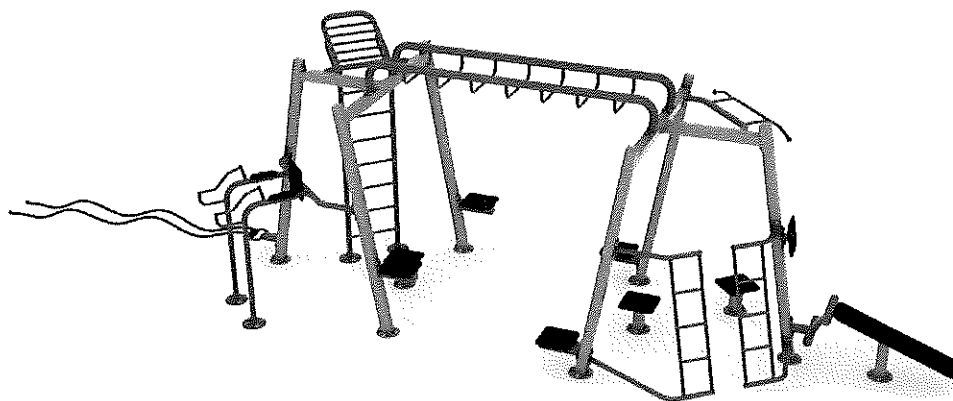

ExoFit Outdoor Fitness Equipment

www.Exo.Fit

800-527-0797

Info@Exo.Fit

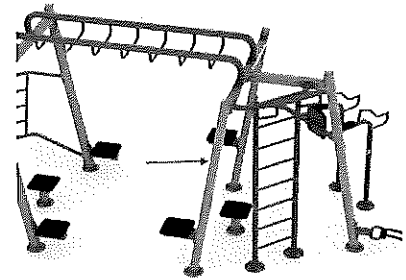
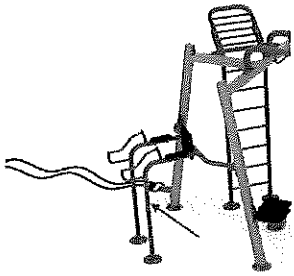

(2 interchangeable knee lift pieces, packaged together)

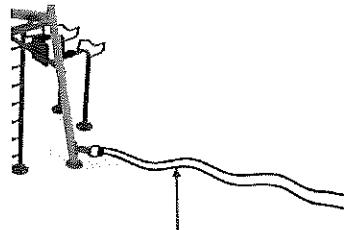
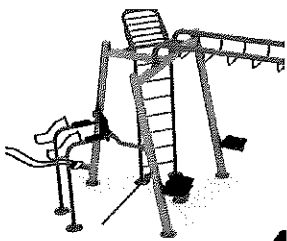
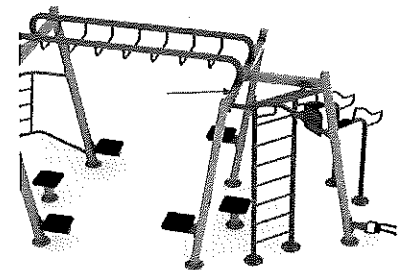
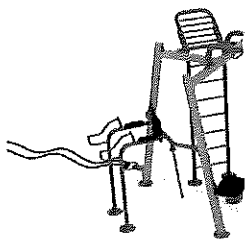

(Ropes in box)

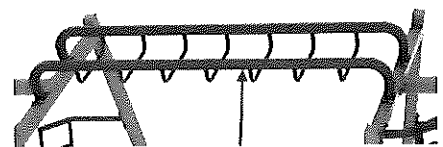

***** AFTER EQUIPMENT IS INSTALLED, REMOVE ALL FILM OFF LABELS *****

"All metal bolt covers are included inside wrapped posts"

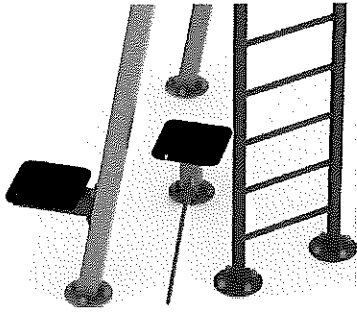

X3

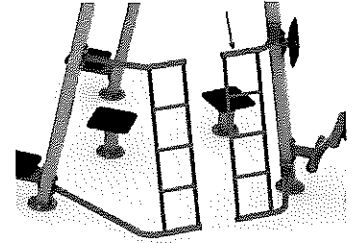
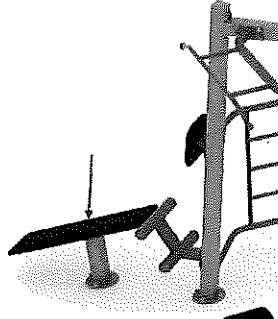

(Both push-up stations
packaged together)

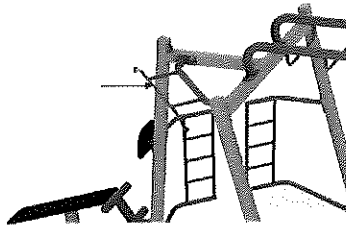
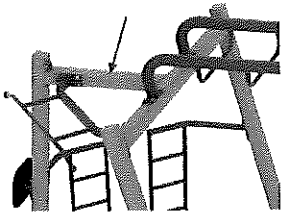
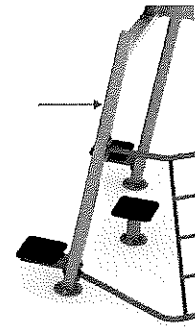
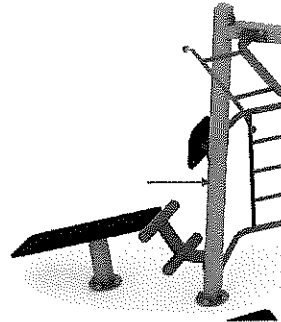
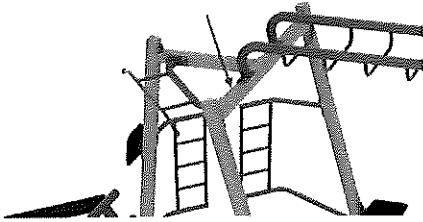

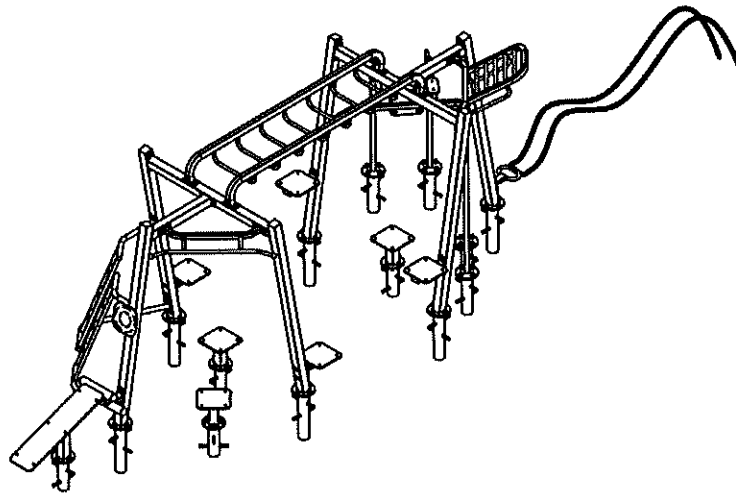
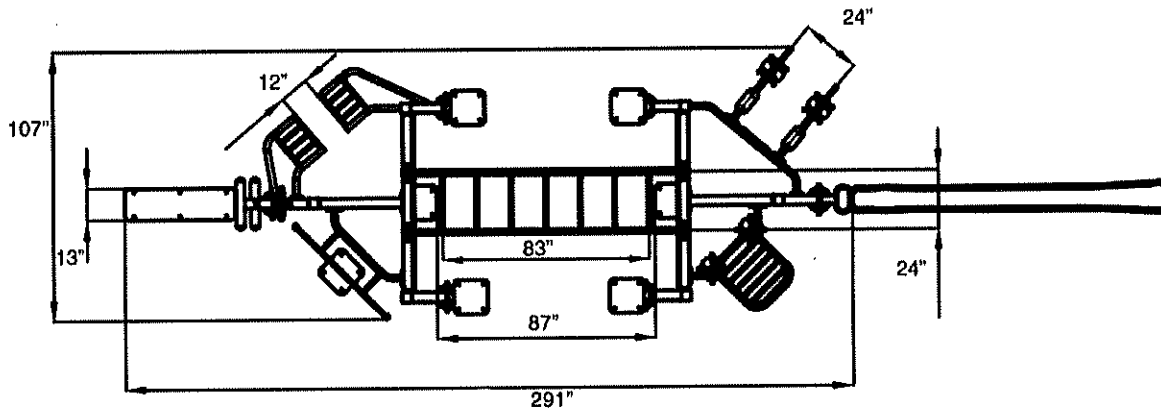
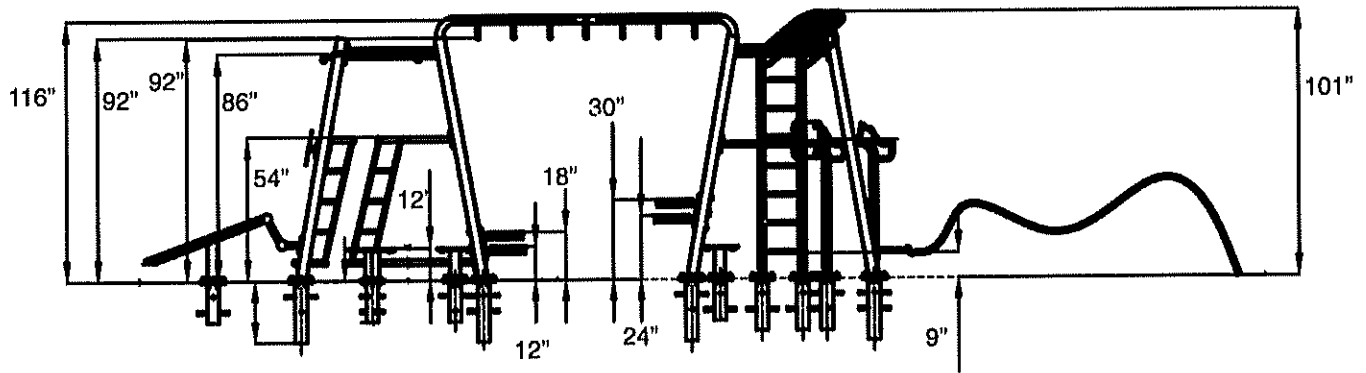

ExoFit Outdoor Fitness Equipment

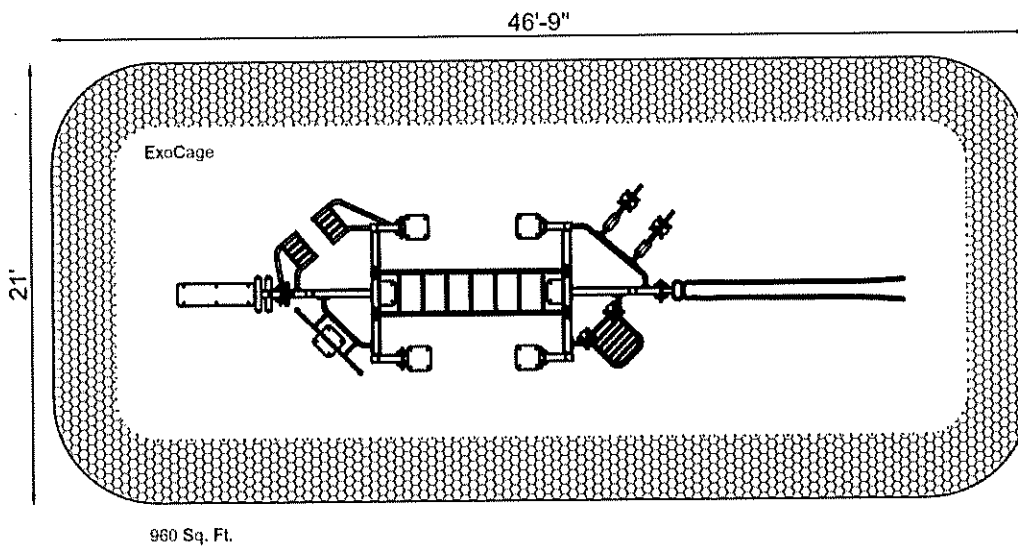
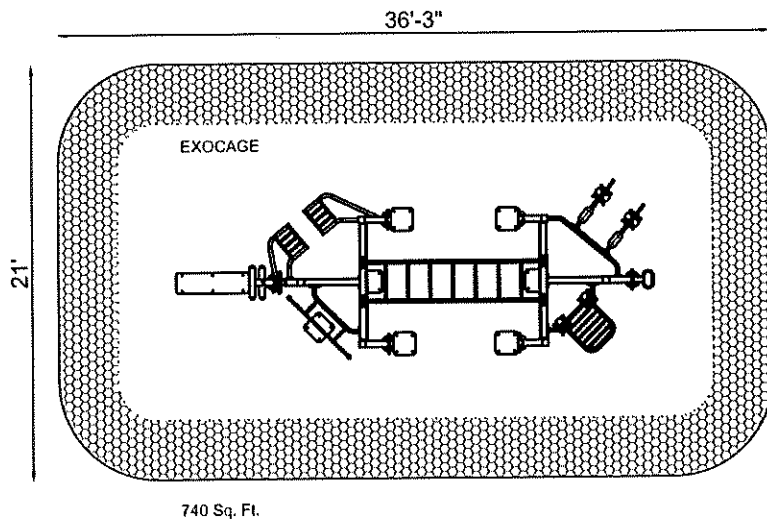

"All metal bolt covers are included inside wrapped posts".

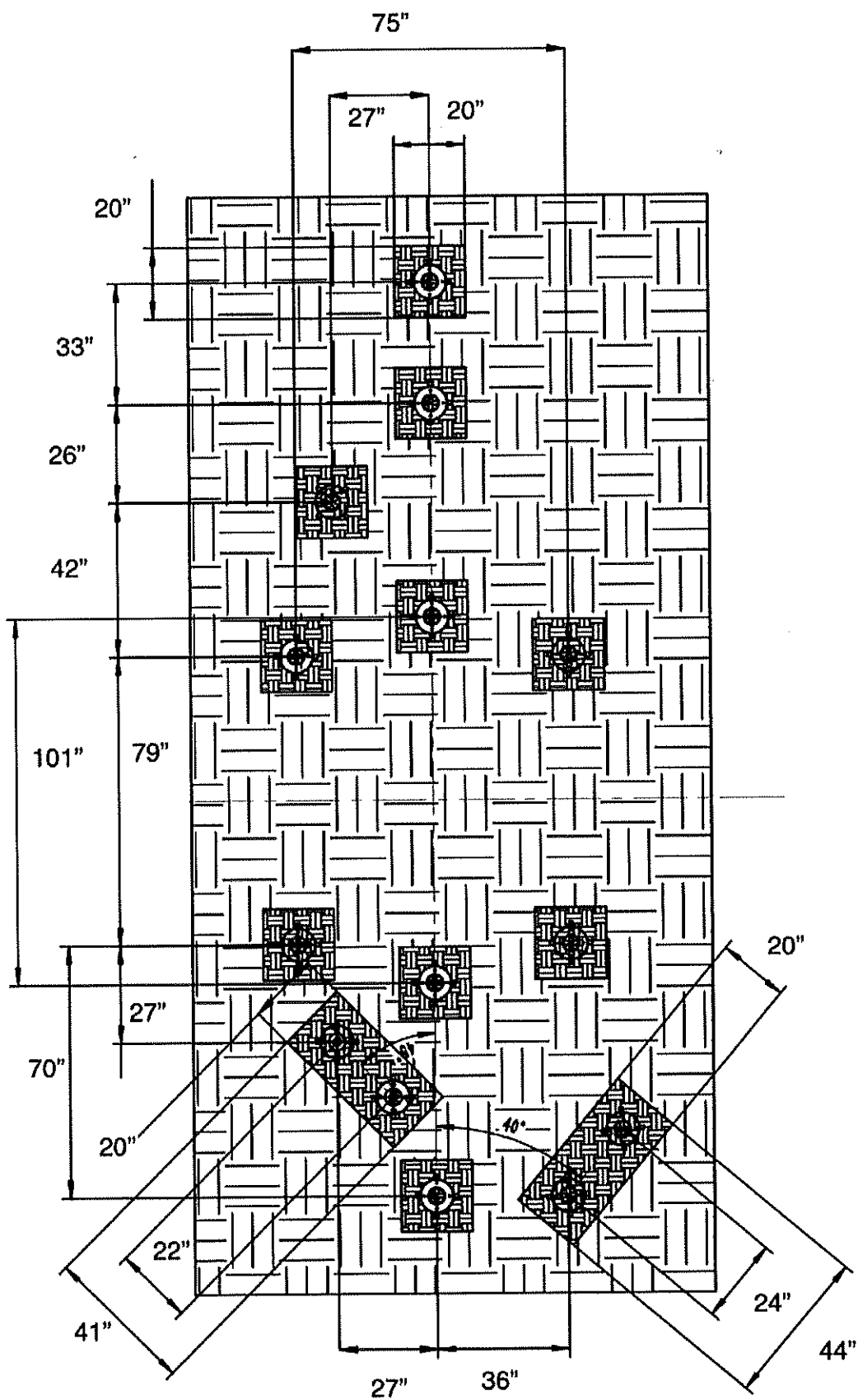

Surface Mount Installation

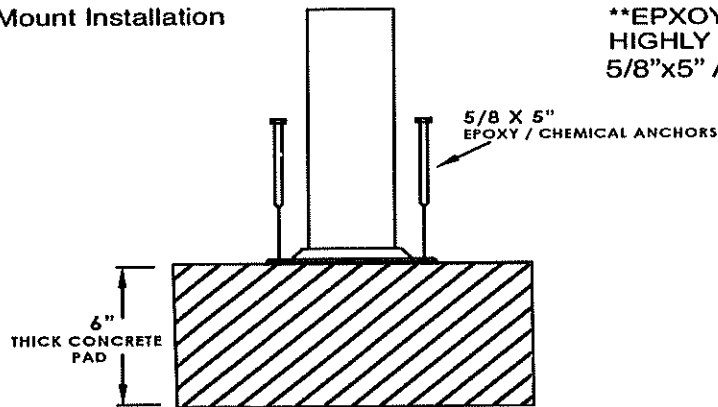

****EPOXY/CHEMICAL ANCHORS HIGHLY RECOMMENDED****
5/8"x5" Anchors recommended

Surface Mount (Main Post)

****Epoxy/Chemical Anchors are recommended for Surface Mount****

In-Ground Mount Installation (Main Support Posts)

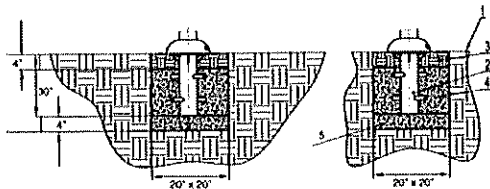

Ref	Name
1	Ground Level
2	Anchor
3	Top Soil
4	Concrete
5	Concrete Block

For in-ground mount, attach embedded anchors to the bottom of all posts first before putting them into footers.

****All bolts needed are located in the posts where the equipment bolts to them. For in-ground installation, bolts for the embedded anchors are attached to the anchors****

*****AFTER EQUIPMENT IS INSTALLED, REMOVE ALL FILM OFF LABELS*****

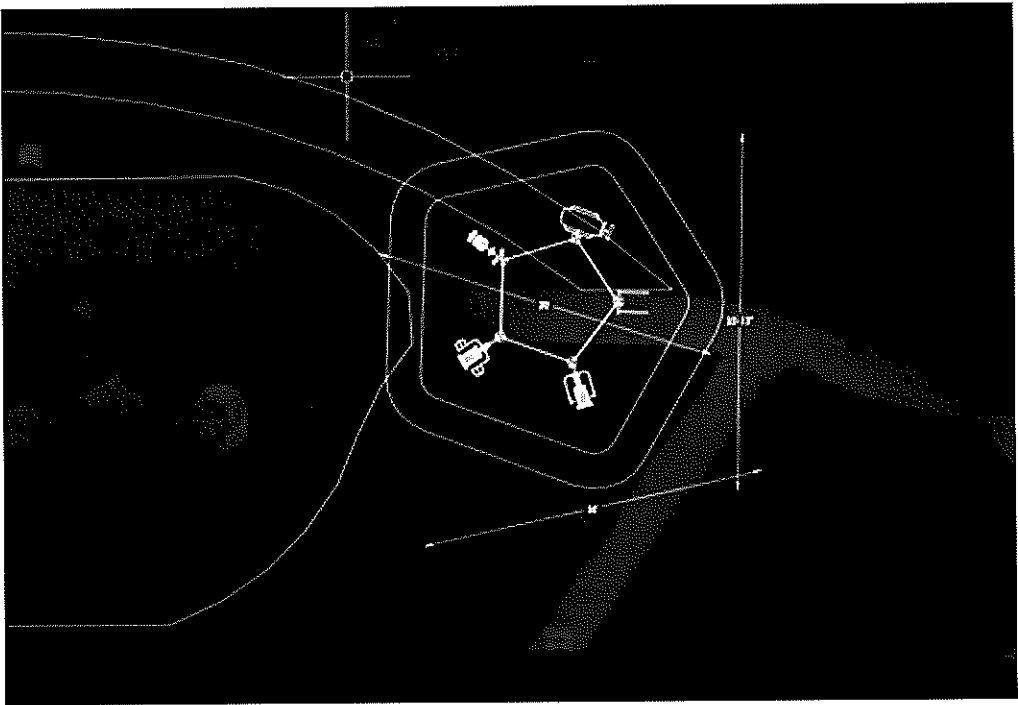



1279 Hazelton-Etna Road SW
 Pataskala, OH 43062
 614-855-3790
 www.midstatesrecreation.com

QUOTATION

Sold To	WI- Bayside, Village of 9075 N Regent Rd Bayside , WI, 53217 United States	Ship To	WI- Bayside, Village of 600 E Ellsworth Ln Bayside, WI, 53217 United States
----------------	---	----------------	--

Date	Quote #	Terms	Rep	Project	Ship Contact
2021-04-29	QTN-07339 Valid Until 05-29-2021		Melanie Breunig	2021 03 Ellsworth Park - WI- Bayside, Village Of	Leah Hofer (414) 206-3914

Item Code	Description	Qty	Rate	Amount
ExoFit Outdoor Fitness	ExoFit Outdoor Fitness: ExoPod	1.0 Unit	\$ 17,599.00	\$ 17,599.00
Freight	Shipping Charges are estimated and are subject to actual shipping charges incurred at time of shipment.	1.0 Unit	\$ 1,944.00	\$ 1,944.00
Customer Discount	Customer Discounts	1.0 Unit	\$ -977.15	\$ -977.15

Subtotal	\$ 18,565.85
WI - Milwaukee 5.6%	\$ 0.00
Total	\$ 18,565.85

Signature _____
 (Approval)

Printed Name _____

Title _____

Date _____



APPLICATION FOR SPECIAL EXCEPTION TO THE ZONING CODE REQUIREMENTS

The Board of Appeals, pursuant to Wis. Stats. 62.23(7)(e) and after appropriate notice and hearing, may, with regard to any requirement imposed by the Zoning Code, or any other section of the Municipal Code which specifically allows for special exceptions, recommend a special exception to the Village Board for approval. Notice of application for special exception shall be provided to all property owners adjoining or abutting the property proposed for a special exception. Denials of special exceptions shall not be appeal able to the Village Board.

1. State the section of the Village of Bayside Municipal Code that you are appealing.

Sec. 125-91. - "C" residence district regulations.

b5: A rear yard of not less than 20 feet shall be provided for every building,

except one of not less than ten feet shall be provided for a building used for or classified as an accessory use.

2. Give a brief description of what you want to do and why.

We would like to replace the shed where it is standing. An 8'x10' concrete slab is already under the current shed. The fence currently ends at the shed and would need additional posts if moved.

The neighbors have expressed displeasure with the state of the shed and would be fine with a replacement shed in the same location.

3. State why compliance with Municipal Code is unreasonably burdensome or negatively impacting upon the use of the property.

The cost of the shed is just shy of \$3K. If we can't place the new shed in the same place, we will have to demolish the concrete, pour a new concrete pad, and put up new fencing. This will more than double the cost of the shed. Also, the value of the property will decrease if we move the shed as the small backyard will have a shed closer to the center of the yard.

Applicant Printed Name

Matt Evans

Applicant Signature

[Handwritten signature]



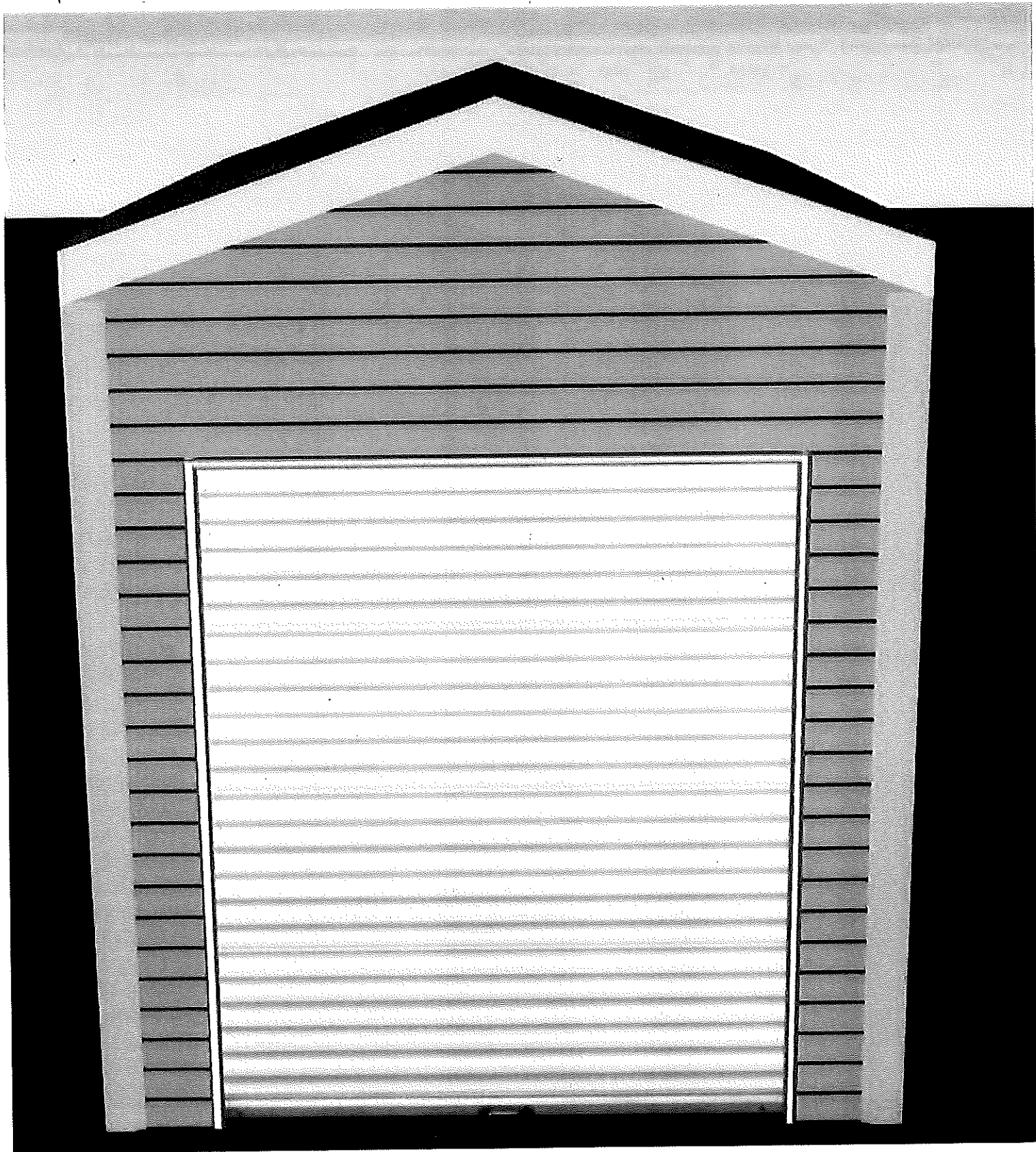

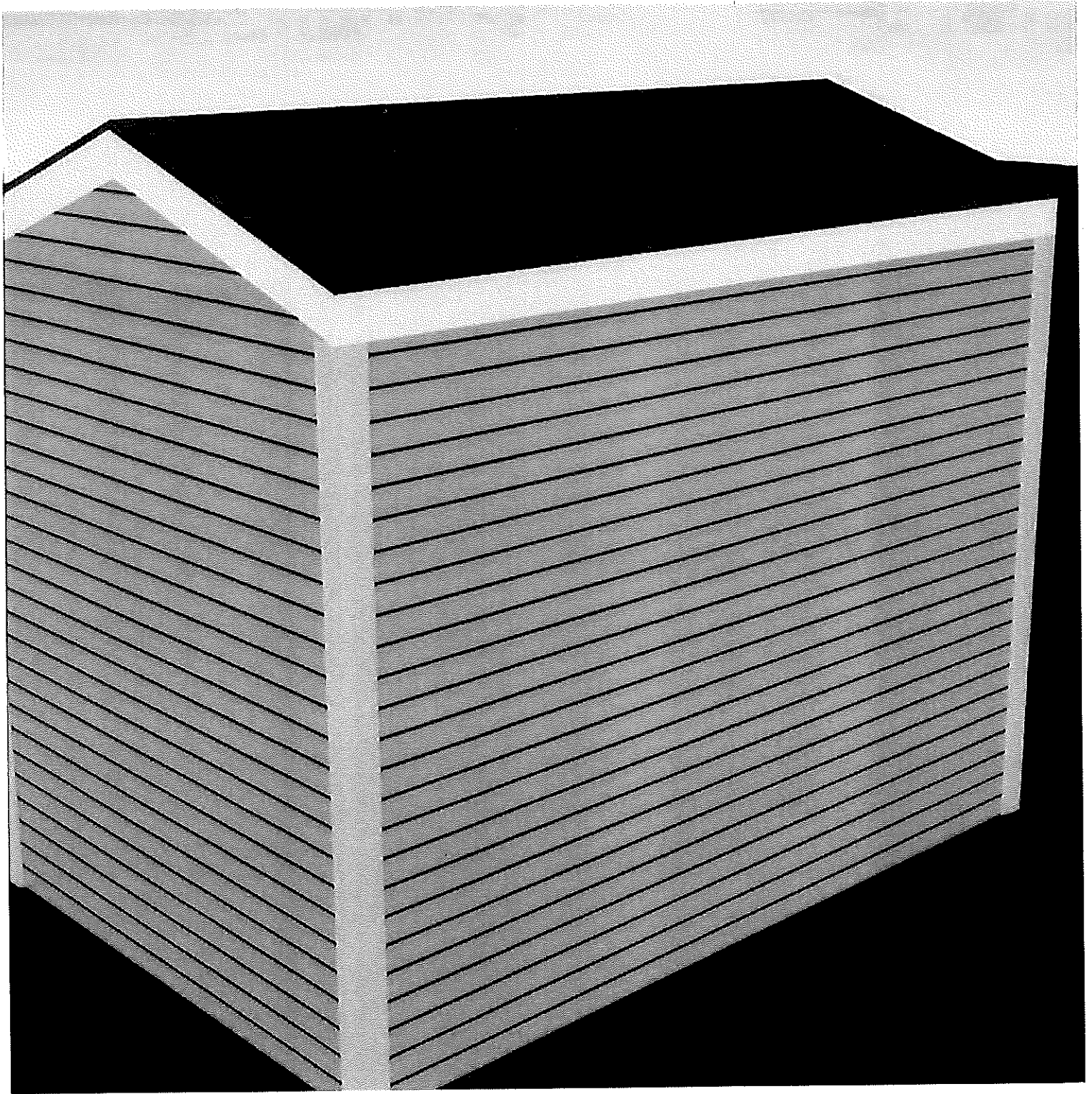

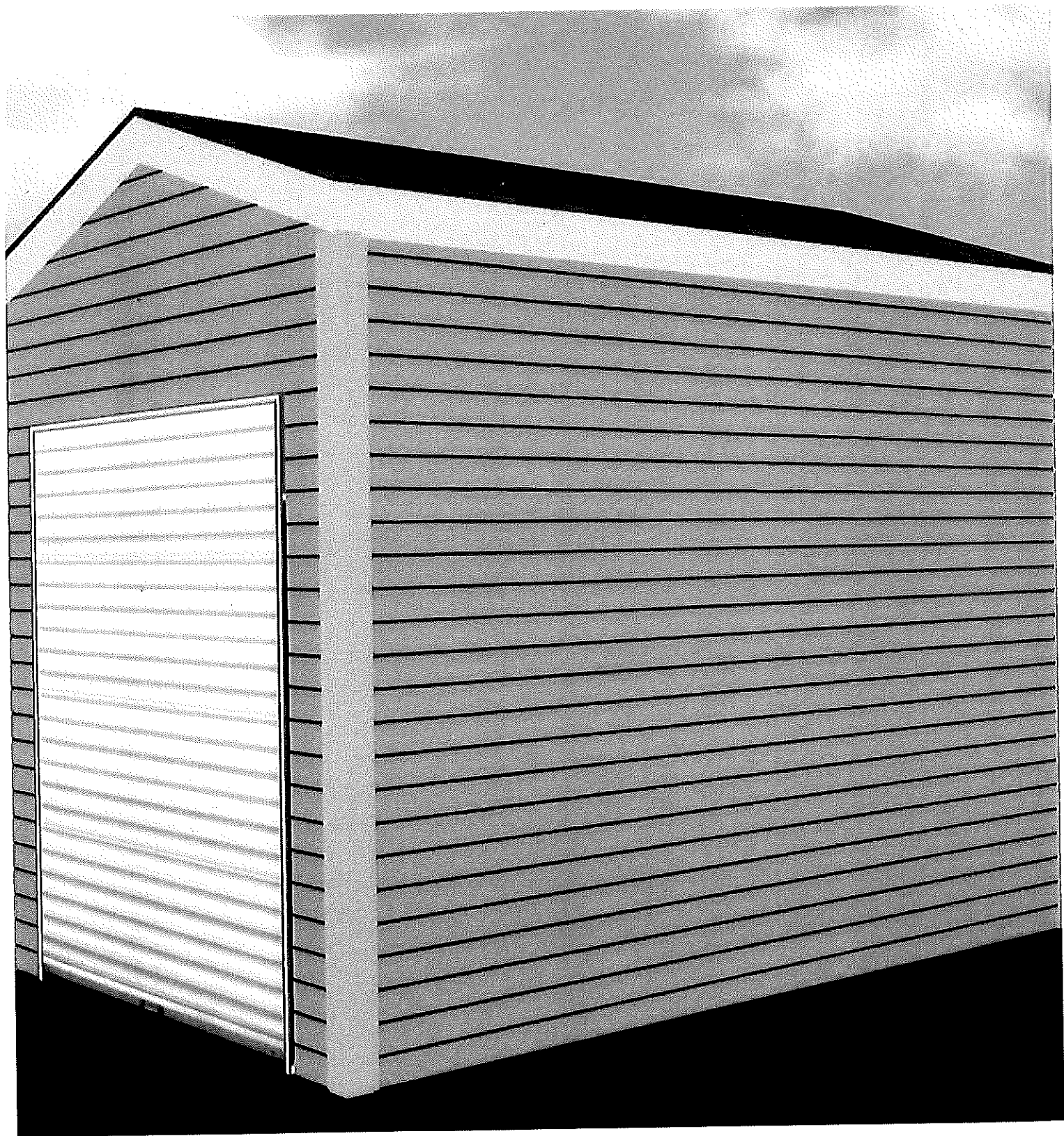

April 22, 2020

Village of Bayside
9075 N Regent Rd,
Bayside, WI 53217

Village of Bayside,

This letter is to acknowledge that Matt and Claire Evans have discussed the plan to replace the current shed with their neighbors. The shed is located on the Southeast corner of the property. All neighbors have had a chance to discuss this plan with Matt and Claire and have agreed that the new shed can be built in the existing shed's location without issue. This shed will be the same size as the existing shed with vinyl siding colored in sandstone that will match the house on the property and a roof made of architectural shingles.

Thank you,

Matt and Claire Evans
309 East Fairy Chasm Road
Bayside, WI 53217

Neighbor Signatures

Signature: [Handwritten Signature]
Name: Kavita Tedamrongmanish

Address: 9170 N Regent Rd

SE
31
4/22/2021
Date

Signature: [Handwritten Signature]
Name: Diana Pogoriler

Address: 9185 N Rexleigh Dr

4/22/2021
Date

Signature: [Handwritten Signature]
Name: Christopher J. Stone

Address: 9171 N Rexleigh Dr

4/22/21
Date

or expiration date **CONDITIONAL USE** of conditional use permit; special requirements characteristics **PERMIT APPLICATION**

PLEASE PRINT OR TYPE



CONDITIONAL USE PERMIT APPLICATION

PLEASE PRINT OR TYPE

Applicant Name(s) _____ Matheau Recht & Debbie Recht

Name of business or development _____ R.Design _____

Address of proposed business _____ 333 W. Brown Deer Road, Suite #10 (J), Milwaukee, WI 53217

Applicant address _____ 873 Autumn path lane Bayside Wisconsin
53217 _____

Applicant phone number(s) _____ 414.403.0631 _____

Property owner name _____
Ned Brickman (midland property)
Property owner address _____ 555 West Brown Deer Road, #220 Milwaukee, WI
53217 _____ Phone number _____ 414.928.3972 _____

Parcel number _____

Conditional Use Permit Plan of Operation

Please Answer all questions and attach additional sheets as necessary. If you do not answer a question, provide a justification for why it does not apply to you.

New Conditional Use Permit Amended Conditional Use Permit

Address of Business: 333 West Brown deer Rd Unit J bayside Wisconsin 53217

Brief overview of specific uses of entire property or lease space and summary of type of business planned: Interior design studio/ show room by appointment only. Use the space for Office on a daily bases. Client presentations.

A brief description of on-site operations: Interior design office, Daily tasks for running a design business. Putting presentations together for clients.

Legal description of property: Shopping center

Tax Key ID Number/Parcel Number: 053-9995-004

Zoning of property: zone D.business district

Lot size or lease space size (in square feet): 1100

Building dimensions and number of floors: 1 floor

Total floor area (in square feet): 1

Number of shifts and maximum number of employees per shift: 1 shift Maximum maximum of 4 people

Days and hours of operation by by appointment only Monday-Friday.

Frequency of deliveries to site and type(s) of vehicles that will deliver: 4-8 per week UPS/fedex

Projected traffic circulation: by appointment only

Signage (type, lighting, size, location, existing or new etc.) *All signs must be approved by the ARC: Sign is in accordance with the landlords specification. The sign does light up.

Describe proposed on-site security measures: ADT security system

Describe the noise, odors, glare, dust, potential fire hazards, or smoke resulting from the proposed use: None

Status of interior plans requiring State approval: _____

Status of State License(s) and/or Certificate(s) required for operation: _____

List the timetable for completion of all building construction or interior construction/remodeling and the anticipated opening

date: 4/25/2021

Anticipated maximum number of facility users and visitors at one time (including special events): 10

Total number of estimated parking spots needed for operation: 4

Dumpster enclosure and trash removal: Use trash and dumpsters that the shopping center provides.

Does the applicant have the legal authority to act for and obligate the company or corporation? Yes No

Does the applicant have the legal authority to act for and obligate the property owner? Yes No

Is the property owner(s) knowledgeable of the request for a Conditional Use? Yes No

Does the property owner agree with the Conditional Use request? Yes No

Signature of applicant (s) NR Date 3/25/2021

*Attach a legal description of the property requested for a conditional use, a plat of survey of the property, and a drawing of any proposed development.

OFFICE USE ONLY:

Application received by: _____

\$300.00 application fee: _____

Public Hearing date: _____

\$100.00 occupancy permit fee: _____

Board of Trustees Meeting: _____

Approved by Board of Trustees: _____

Occupancy Permit Issued?: _____

NSFD Permit Issued?: _____

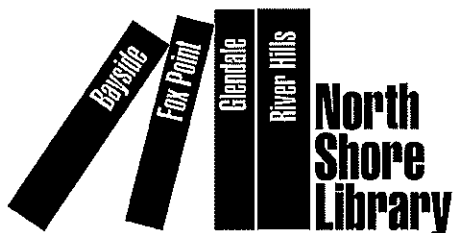

North Shore Library April 2021

Highlights / Accomplishments

- New Team Members! Library Director Annie Bahringer started on April 26th, 2021 and is having a great time learning everything, working with the staff, and brainstorming ideas! Hannah Kane will begin her role of Head of Youth Services, taking care of all things kids and teens, on May 17th, 2021.
- Library usage is continuing to increase and in April 2021, community usage is nearing pre-pandemic levels. Total circulation of library materials in April 2021 went down slightly from March 2021, but we can attribute this to Spring Break vacations.
- Last year, the library closed our doors in response to the COVID-19 Pandemic. While the Library services have changed and adapted, we've been able to connect with community members in new and creative ways and we've been very grateful to serve such a compassionate and resilient community.
- Virtual programs continue to be a hit with our patrons. Our Take and Make crafts have been fun and appreciated by community members of all ages.

Percent changes are based on April 2020 statistics.

PHYSICAL ITEMS
CHECKED OUT

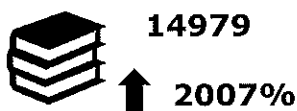

E-ITEMS CHECKED OUT



CURBSIDE PICK-UPS



NEW CARDS ISSUED



DAYS OPEN

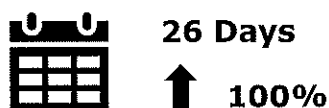

WEBSITE VISITS



VISITORS



COMPUTER SESSIONS



OF CHILDRENS
CLASSES



OF ADULT CLASSES



PARTICIPANTS IN
ADULT CLASSES



PARTICIPANTS IN
CHILDRENS CLASSES





Committee/Board/Commission Questionnaire

Thank you for your interest in becoming involved with a Village of Bayside Committee, Board or Commission. As you may already know, the Village President recommends all citizen appointments to the Village Board for approval. Please provide them with some information to use when considering your appointment by completing the questions below. Also, you are welcome to attach additional information which may further support your appointment.

Name: (as you like to be addressed) Joe Ellner

Address: 9459 N. Fairway Circle Phone #: 414-460-0646

E-Mail: joe.ellner@trupanion.com Years as Village of Bayside Resident: 21

What Village committee(s) are you currently serving on, if any? None

Would you like to be re-appointed? (Circle one) Yes No

Committee/Board/Commission you are interested in: Development Committee

Why are you interested in serving on this particular group: Interest in revitalizing business + village in Bayside

Qualifications for serving on this group: longtime Bayside resident, business owner

Other Community Involvement: Board member - Mount Zion Cemetery

Occupation/Employer: Trupanion - medical insurance for pets

Family Details: (optional) wife - Michele, 3 children

Leisure Activities/ Hobbies: (optional) sports, bikes, running, fishing

Signature:  Date: 5/13/21