

10/05/2021

Attention:
Village of Bayside, WI
Architecture Review Committee

PROJECT/SITE OWNER: John Schreiber PROJECT ADDRESS: 9540 N Regent	PROJECT SUMMARY: New 8' X 12' 96 sq. Ft. storage shed
--	--

I have reviewed the proposed new shed for compliance with the Village's ordinances and have determined the following for consideration

Sec. 125-90. - "B" residence district regulations.

- (4) A side yard of not less than ten feet shall be provided for on each side of every building.
- (5) A rear yard of not less than 20 feet shall be provided for every building, except one of not less than ten feet shall be provided for a building used for or classified as an accessory use.

1. Unable to confirm the rear set back as there is no measurement on the survey, however when comparing side setback to rear yard space it appears to meet the rear yard setback

- 2. Confirms with the Impervious requirements
- 3. Confirms with the size limit requirements.

104-2(a)(2) Architectural Review Committee: *Construction and renovation should be made so that exterior architectural appearance shall be substantially consistent with structures already constructed in the immediate neighborhood, or with the character of the applicable district.*

VILLAGE CODE REVIEW

Supporting documentation or testimony must be provide at the meeting to verify code compliance with the above observations in red.

Dave Hendrix
SAFEbuilt
Wisconsin Operations Manager

Project Proposal

Date 10/21
 Property Address 9540 N. Regent
 Zoning _____

- | | |
|--|--|
| <input checked="" type="checkbox"/> Accessory Structures/Generators
<input type="checkbox"/> Additions/Remodel
<input type="checkbox"/> Bluff Management
<input type="checkbox"/> Commercial Signage
<input type="checkbox"/> Decks/Patios
<input type="checkbox"/> Fence
<input type="checkbox"/> Fire Pits
<input type="checkbox"/> Landscaping requiring Impervious Surface/Fill/Excavation Permit | <input type="checkbox"/> New Construction
<input type="checkbox"/> Play Structures
<input type="checkbox"/> Recreational Facilities/Courts
<input type="checkbox"/> Roofs
<input type="checkbox"/> Solar Panels/Skylights
<input type="checkbox"/> Swimming Pools
<input type="checkbox"/> Windows/Doors-change exceeds 25% of opening
<input type="checkbox"/> Other |
|--|--|

Proposed project details (type of work, size, materials, etc.):

Storage Shed 12' * 8'

***** For Office Use Only *****

Yes	No	
<input type="checkbox"/>	<input type="checkbox"/>	Color photographs showing project location, elevations and surrounding views
<input type="checkbox"/>	<input type="checkbox"/>	Two (2) complete sets of building plans (including elevations and grading)
<input type="checkbox"/>	<input type="checkbox"/>	Survey
<input type="checkbox"/>	<input type="checkbox"/>	Samples or brochures showing materials, colors and designs
<input type="checkbox"/>	<input type="checkbox"/>	Application Fee
<input type="checkbox"/>	<input type="checkbox"/>	Parcel Number
<input type="checkbox"/>	<input type="checkbox"/>	ARC Agenda Date:
<input type="checkbox"/>	<input type="checkbox"/>	Building Permit
<input type="checkbox"/>	<input type="checkbox"/>	Fill Permit
<input type="checkbox"/>	<input type="checkbox"/>	Impervious Surface Permit
<input type="checkbox"/>	<input type="checkbox"/>	Plan Commission/Conditional Use Permit
<input type="checkbox"/>	<input type="checkbox"/>	Tax Key Number
<input type="checkbox"/>	<input type="checkbox"/>	Right-of-Way/Excavation Permit
<input type="checkbox"/>	<input type="checkbox"/>	Variance Required

1-262-346-4577 SAFEbuilt, Inc.	WI UNIFORM PERMIT APPLICATION hartfordinspections@sarebuilt.com Inspections need to be called in by 4 pm for next business day inspections	PERMIT NO. TAXKEY# <u>0170031000</u>
-----------------------------------	---	---

ISSUING MUNICIPALITY	<input type="checkbox"/> TOWN <input checked="" type="checkbox"/> VILLAGE <input type="checkbox"/> CITY OF <u>BAYSIDE</u> COUNTY: <u>MILWAUKEE</u>	PROJECT LOCATION (Building Address) 9540 N. REGENT	PROJECT DESCRIPTION SHED <input type="checkbox"/> COMMERCIAL <input checked="" type="checkbox"/> ONE & TWO FAMILY
-----------------------------	--	--	---

Owner's Name JOHN SCHREIBER	Mailing Address - Include City & Zip 9540 N. REGENT ROAD, BAYSIDE, WI 53217	Telephone - Include Area Code 4148994892
Construction Contractor (DC Lic No.) COSTCO (YARDLINE)	Mailing Address - Include City & Zip	Telephone - Include Area Code
Dwelling Contractor Qualifier (DCQ Lic No.)	Dwelling Contractor Qualifier shall be an owner, CEO, COB, or employee of Dwelling Contractor	Telephone - Include Area Code
Plumbing Contractor (Lic No.)	Mailing Address - Include City & Zip	Telephone - Include Area Code
Electrical Contractor (Lic No.)	Mailing Address - Include City & Zip	Telephone - Include Area Code
HVAC Contractor (Lic No.)	Mailing Address - Include City & Zip	Telephone - Include Area Code

PROJECT INFORMATION	Subdivision Name RAVINE PARK	Lot No. 31	Block No. 1	
Zoning District	Lot Area 33,500 Sq. Ft.	N.S.E.W. Setbacks	Front Ft.	Rear Ft.
			Left Ft.	Right Ft.

1a. PROJECT <input type="checkbox"/> New <input type="checkbox"/> Addition <input type="checkbox"/> Raze <input type="checkbox"/> Alteration <input type="checkbox"/> Repair <input type="checkbox"/> Move <input checked="" type="checkbox"/> Other <u>STORAGE SHED</u>	3. TYPE <input type="checkbox"/> Single Family <input type="checkbox"/> Two Family <input type="checkbox"/> Multi <input type="checkbox"/> Commercial	6. STORIES <input type="checkbox"/> 1-Story <input type="checkbox"/> 2-Story <input checked="" type="checkbox"/> Other <u>SHED</u>	9. HVAC EQUIPMENT <input type="checkbox"/> Forced Air Furnace <input type="checkbox"/> Radiant Baseboard or Panel <input type="checkbox"/> Heat Pump <input type="checkbox"/> Boiler <input type="checkbox"/> Central Air Conditioning <input type="checkbox"/> Other _____	12. ENERGY SOURCE <table border="1" style="width:100%; border-collapse: collapse;"> <tr> <th>Fuel</th> <th>Nat. Gas</th> <th>L.P.</th> <th>Oil</th> <th>Elec. *</th> <th>Solid</th> <th>Solar</th> </tr> <tr> <td>Space Htg</td> <td><input type="checkbox"/></td> <td><input type="checkbox"/></td> <td><input type="checkbox"/></td> <td><input type="checkbox"/></td> <td><input type="checkbox"/></td> <td><input type="checkbox"/></td> </tr> <tr> <td>Water Htg</td> <td><input type="checkbox"/></td> <td><input type="checkbox"/></td> <td><input type="checkbox"/></td> <td><input type="checkbox"/></td> <td><input type="checkbox"/></td> <td><input type="checkbox"/></td> </tr> </table> <p><input type="checkbox"/> Dwelling unit will have 3 kilowatt or more installed electric space heater equipment capacity.</p>	Fuel	Nat. Gas	L.P.	Oil	Elec. *	Solid	Solar	Space Htg	<input type="checkbox"/>	<input type="checkbox"/>	<input type="checkbox"/>	<input type="checkbox"/>	<input type="checkbox"/>	<input type="checkbox"/>	Water Htg	<input type="checkbox"/>	<input type="checkbox"/>	<input type="checkbox"/>	<input type="checkbox"/>	<input type="checkbox"/>	<input type="checkbox"/>
Fuel	Nat. Gas	L.P.	Oil	Elec. *	Solid	Solar																			
Space Htg	<input type="checkbox"/>	<input type="checkbox"/>	<input type="checkbox"/>	<input type="checkbox"/>	<input type="checkbox"/>	<input type="checkbox"/>																			
Water Htg	<input type="checkbox"/>	<input type="checkbox"/>	<input type="checkbox"/>	<input type="checkbox"/>	<input type="checkbox"/>	<input type="checkbox"/>																			
1b. GARAGE <input type="checkbox"/> Attached <input type="checkbox"/> Detached	4. CONST. TYPE <input type="checkbox"/> Site Constructed <input type="checkbox"/> Mfd. UDC <input type="checkbox"/> Mfd. HUD	7. FOUNDATION <input type="checkbox"/> Concrete <input type="checkbox"/> Masonry <input type="checkbox"/> Treated Wood <input type="checkbox"/> ICF <input type="checkbox"/> Other _____	10. PLUMBING Sewer <input type="checkbox"/> Municipal <input type="checkbox"/> Septic No. _____	13. HEAT LOSS (Calculated) Total _____ BTU/HR																					
2. AREA Basement _____ Sq. Ft. Living Area _____ Sq. Ft. Garage _____ Sq. Ft. Other _____ Sq. Ft. TOTAL _____	5. ELECTRICAL Entrance Panel Size: _____ amp Service: ___ New ___ Rewire Phase _____ Volts ____ Underground ____ Overhead Power Company: _____	8. USE <input type="checkbox"/> Seasonal <input type="checkbox"/> Permanent <input type="checkbox"/> Other _____	11. WATER <input type="checkbox"/> Municipal Utility <input type="checkbox"/> Private On-Site Well	14. ESTIMATED COST \$3000																					

I understand that I: am subject to all applicable codes, laws, statutes and ordinances, including those described on the Notice to Permit Applicants form; am subject to any conditions of this permit; understand that the issuance of this permit creates no legal liability, express or implied, on the state or municipality; and certify that all the above information is accurate. If one acre or more of soil will be disturbed, I understand that this project is subject to ch. NR 151 regarding additional erosion control and stormwater management and the owner shall sign the statement on the Notice to Permit Applicants form. I expressly grant the building inspector, or the inspector's authorized agent, permission to enter the premises for which this permit is sought at all reasonable hours and for any proper purpose to inspect the work which is being done.

I vouch that I am or will be an owner-occupant of this dwelling for which I am applying for an erosion control or construction permit without a Dwelling Contractor Certification and have read the cautionary statement regarding contractor responsibility on the Notice to Permit Applicants form.

APPLICANT (PRINT): John R. Schreiber JOHN SCHREIBER 8/30/21
 SAFEbuilt, Inc. Signature Date

INSPECTIONS NEEDED Building Footing Foundation Rough Insulation Bsmt. Fl. Final
 Electric Rough Service Final Plumbing Rough Underfloor Final HVAC Rough Final

FEES:	PERMIT(S) ISSUED	SEAL NO. _____	Municipality No. _____
Building Fee _____ Zoning Fee _____ WI Seal _____ Electric Fee _____ Plumbing Fee _____ HVAC Fee _____ Adm. Fee _____ Other _____ Total _____	Bldg. # At top of form _____ Zoning # _____ Elec. # _____ Plmb. # _____ HVAC # _____	RECEIPT CK # _____ Amount \$ _____ Date _____ From _____ Rec By. _____	PERMIT EXPIRATION: Permit expires two years from date issued unless municipal ordinance is more restrictive.
PERMIT ISSUED BY MUNICIPAL AGENT:		Name _____ Date _____ Certification No. _____	



Application for Impervious Surface Permit

Owner's Name: John Schreiber
 Street Address: 9540 N. Regent Road
 Telephone Number: 414.899.4892

I hereby apply for a permit to install impervious surface*

Amount of square footage to be added 96 (8' * 12')
 Type of impervious surface (ex. driveway, sidewalk, etc.) SHED

* Anything over 50 sq. ft. requires a permit and detailed plans with measurement

Estimated Start Date: 10/2021
 Estimated Completion Date: 10/2021

I understand that approval from the Village of Bayside Department of Public Works is required prior to starting and also upon completion of the project.

Owner Signature John R. Schreiber Date 8/30/21

Permission granted to install impervious surface at the above address

DPW Representative _____ Date _____

Final approval granted for completion of installation

DPW Representative _____ Date _____

Permission not granted.

Reason _____

DPW Representative _____ Date _____

Milwaukee County Land Information Parcel Report

TAXKEY: 0170031000

Report generated 8/30/2021 10:12:22 AM

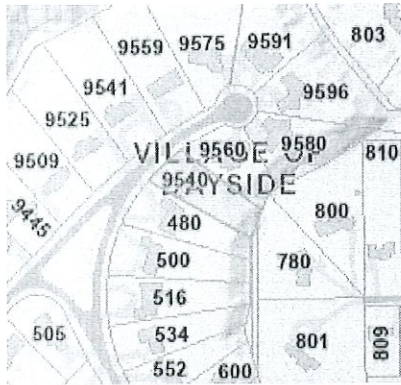

Parcel location within Milwaukee County

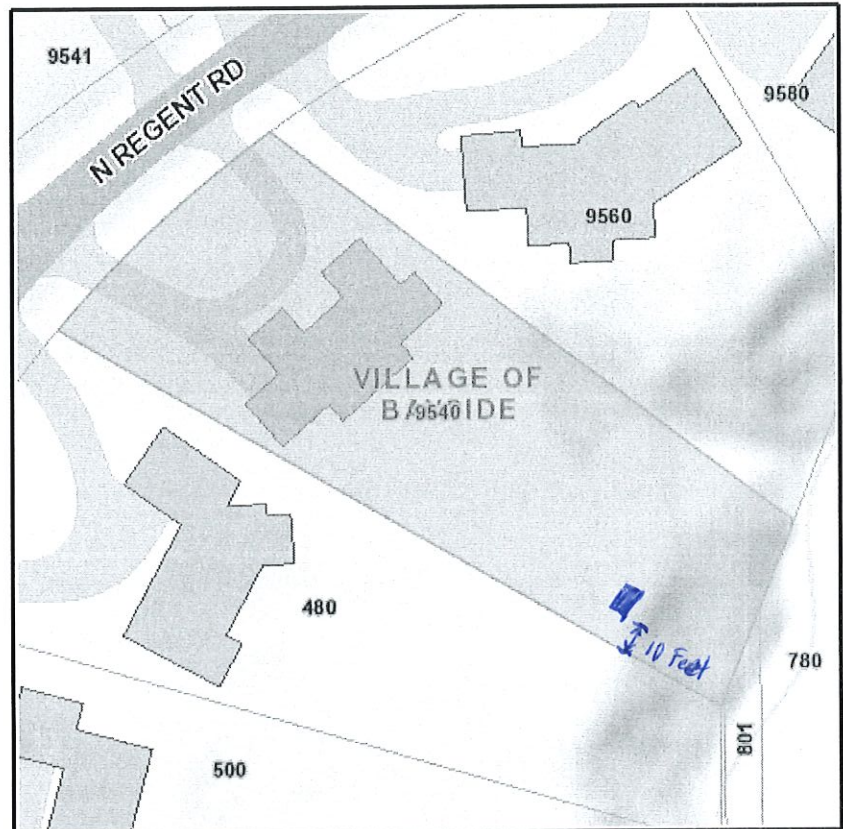

Selected parcel highlighted

Parcel Information

TAXKEY: 0170031000
Record Date: 12/31/2019
Owner(s): JOHN R SCHREIBER
AMANDA B SCHREIBER

Address: 9540 N REGENT RD
Municipality: Bayside
Acres: 0.77

Assessed Value: \$344,200
Land Value: \$140,400
Improvement Value: \$203,800

Parcel Description: RESIDENTIAL

Zoning Description:

Legal Description: BAYSIDE RAVINE PARK LOT 31 BLK 1

School District: NICOLET UHS SCHOOL DISTRICT

This map is a user generated static output from an Internet mapping site and is for reference only. Data layers that appear on this map may or may not be accurate, current, or otherwise reliable.

Costco
P

Home / Patio, Lawn & Garden / Outdoor Storage Sheds

Installed Sheds by Yardline - Aberdeen Shed, 8' x 12'

Item 1408678

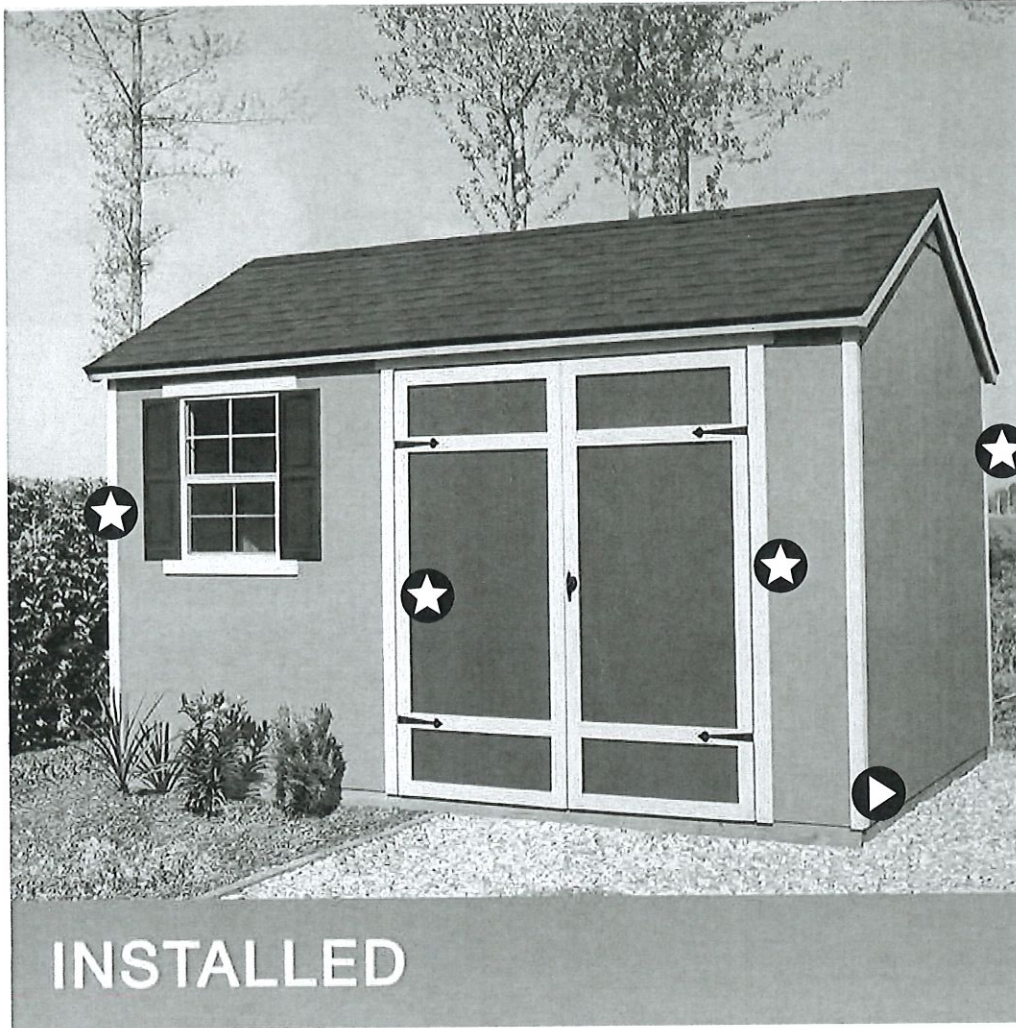

*To be painted
to match color
of house
(Red w/ white
Trim)

Feedback



+4

Your Price

\$2,999.99

Shipping & Handling Included*

Special Event - Ends 9/12/21

Limited Time Offer. While supplies last.

Features:

- Installation and Delivery Included
- Large Window with Shutters
- Loft and Shelf Included
- Decorative Door Hinges
- 64" Double Doors

Add to Cart

Add to List

Share

Arrives approximately 6 - 8 weeks from time of order.

Product Details

Delivery and installation only to the following states: AL AZ CO CT DE GA IA ID IL KY LA MA MO MT NC ND NE NH NJ OK PA TN TX UT VT WA WI WY

Remote service locations may require additional time for delivery.

Product details have been supplied by the Manufacturer, and are hosted by a third party.

Before ordering:

- Be sure to check your local building and zoning codes to ensure that all appropriate permits have been acquired. Always check with your local building authority and home owner's association for any restrictions/requirements before finalizing your purchase
- Siding is pre-primed and ready for paint (paint sold separately)

SPECIAL FEATURES:

- 25-year shingles included with 5 colors to choose from
- Extra-wide 64" double doors accommodate ATV's, wheelbarrows, tractors, lawnmowers and more
- 8"W x 12"D shelf
- 2' deep storage loft
- Large operable window with shutters
- 6'4" tall sidewall height | 9'3" peak height
- Two wall vents provide ventilation
- LP® engineered & treated siding resists rot, decay & insects
 - Siding primed and ready for paint
- Heavy-duty locking handle provides easy access
- Premium 2x4 construction
- Roofing felt for added protection from moisture
- Complete floor system - treated 2x4 joists, 4x4 runners and engineered wood decking
- Aluminum threshold protects your entryway
- Decorative door hinges show off a classic look
- Professional installation included with purchase
- 15-year limited warranty

HIGHLIGHTS

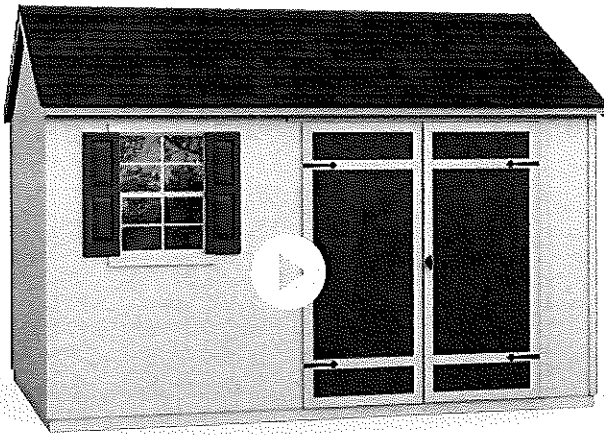

DEMO



MADE HERE. MADE RIGHT.

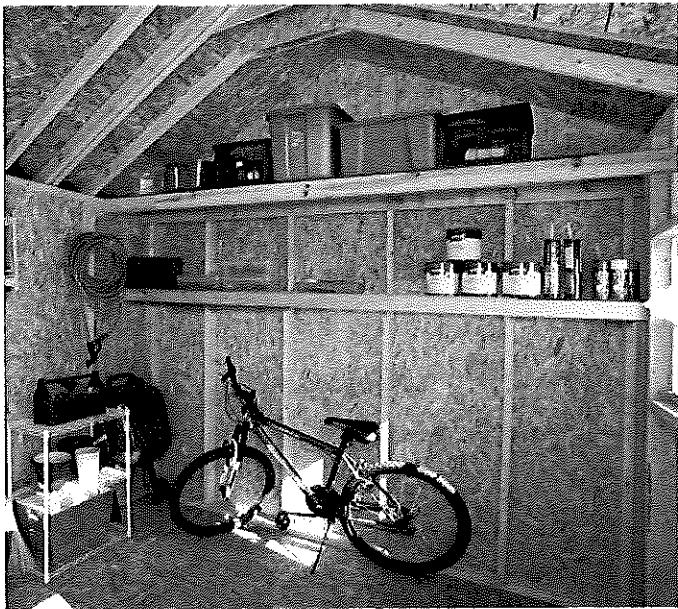

SMART ORGANIZATION SYSTEM

Keeps items organized and within reach.

- 8"W x12"D shelf
- 2' deep storage loft

EXTRA-WIDE 64" DOUBLE DOORS

Industry-leading 64" wide door opening accommodates ATV's, tractors, wheelbarrows or your oversized band gear.

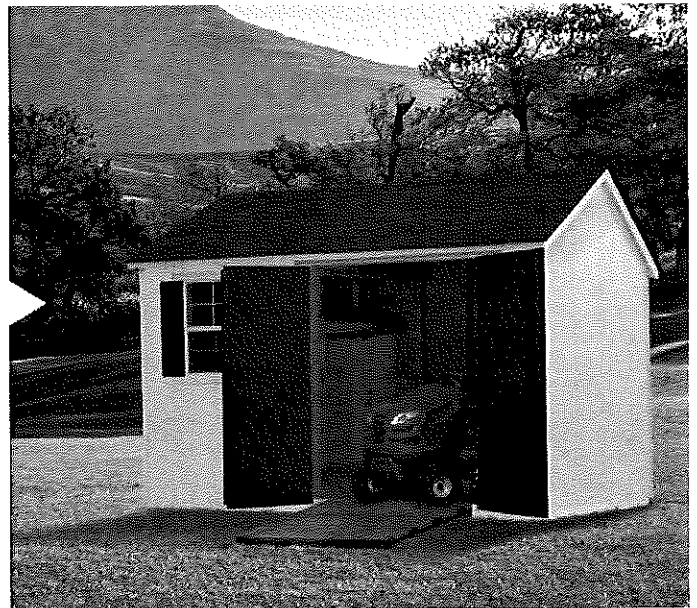

Feedback



LARGE WINDOW WITH SHUTTERS

- Invites natural light inside and makes your shed feel like home
- Window is fully operational
- Includes screen and lock
- Features smart trim
- Size: 22"x30"

HEAVY-DUTY LOCKING HANDLE

Premium handle keeps your items inside secure while proving easy access when you need it.

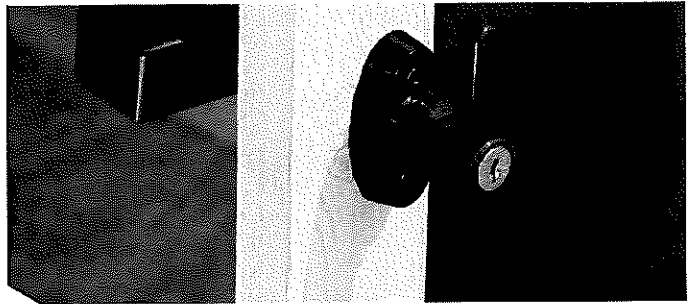

STRONG & DURABLE CONTINUOUS DOOR HINGES

Galvanized continuous piano hinges prevent sagging.

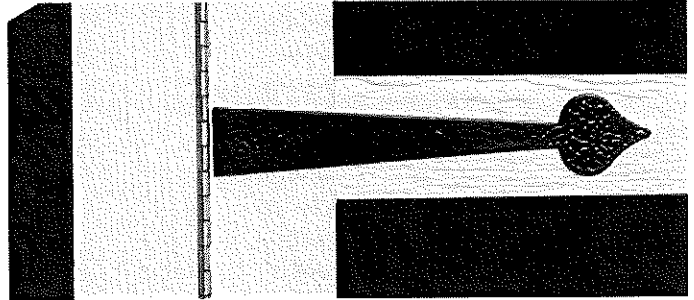

WHY WOOD?

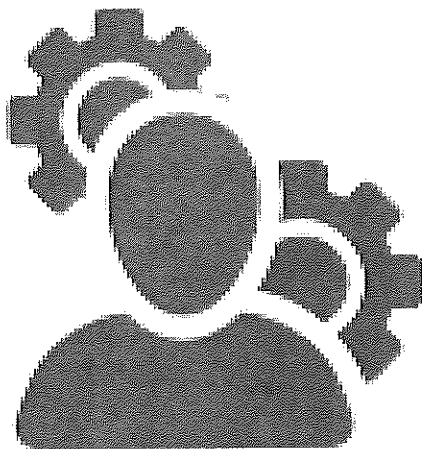

CUSTOMIZABLE

Customize your shed with paint & shingles to match your home. Expand your space with hooks, hangers and shelving.

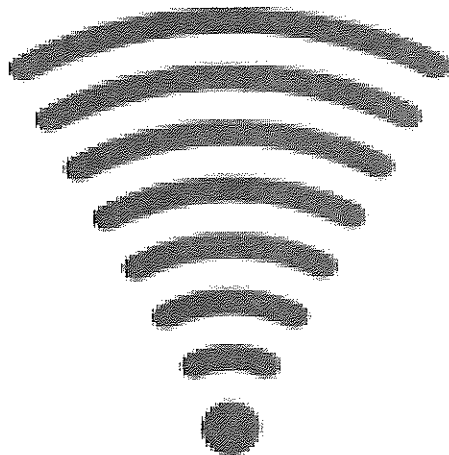

STRONG

Wood has centuries of proven performance to meet demanding wind & snow loads. It won't rust or dent like metal, or sag like plastic.

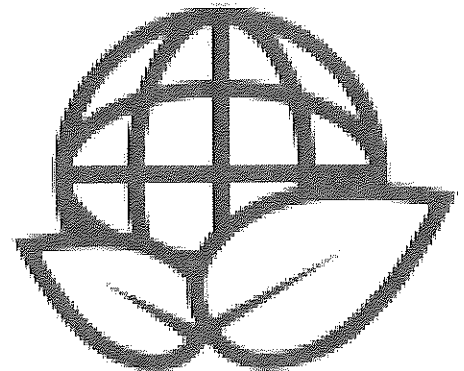

EARTH FRIENDLY

All wood is sourced from sustainable forests for optimal resource usage.

INCLUDES COMPLETE FLOOR SYSTEM

- Constructed of treated 2" x 4" framing with 16" joist spacing
- OSB decking is an engineered wood product designed for strength, durability and consistency
- 5/8" sheets cover the floor frame providing years of safe and dependable storage
- 4x4 runners

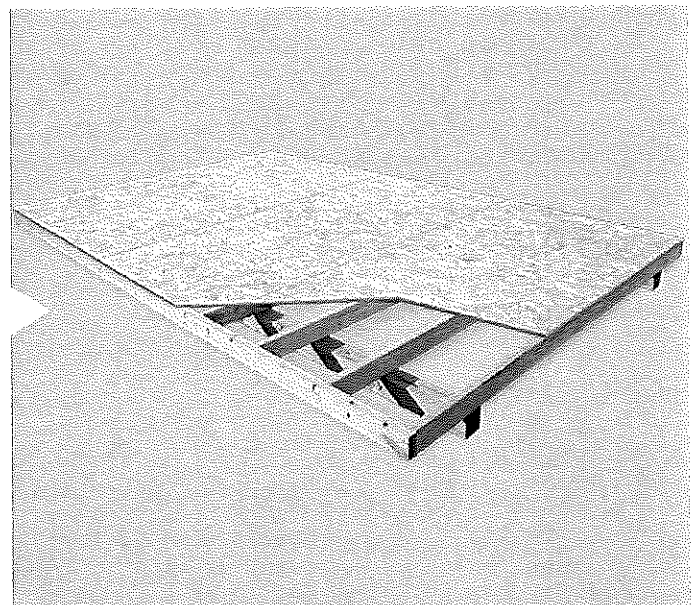

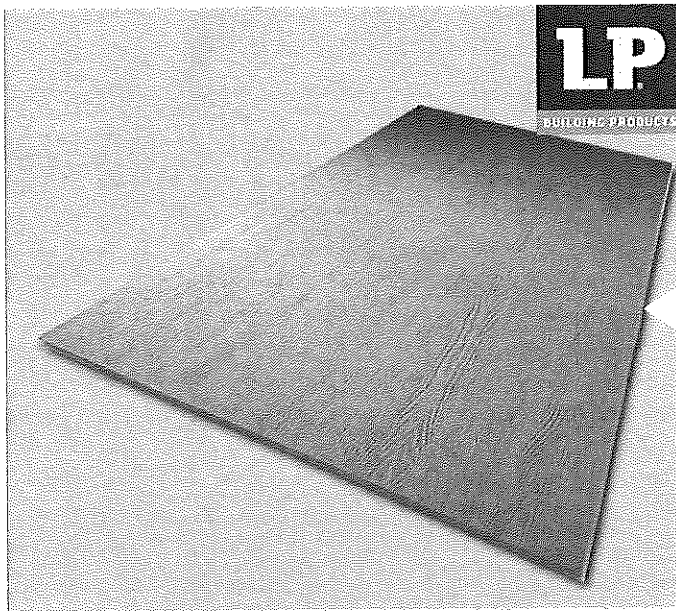

ENGINEERED & TREATED SIDING

- Factory primed & ready to paint
- Treated to resist rot, decay & insects
- Superior dent resistance
- Deeply embossed cedar grain pattern

HOW THE INSTALLATION PROCESS WORKS

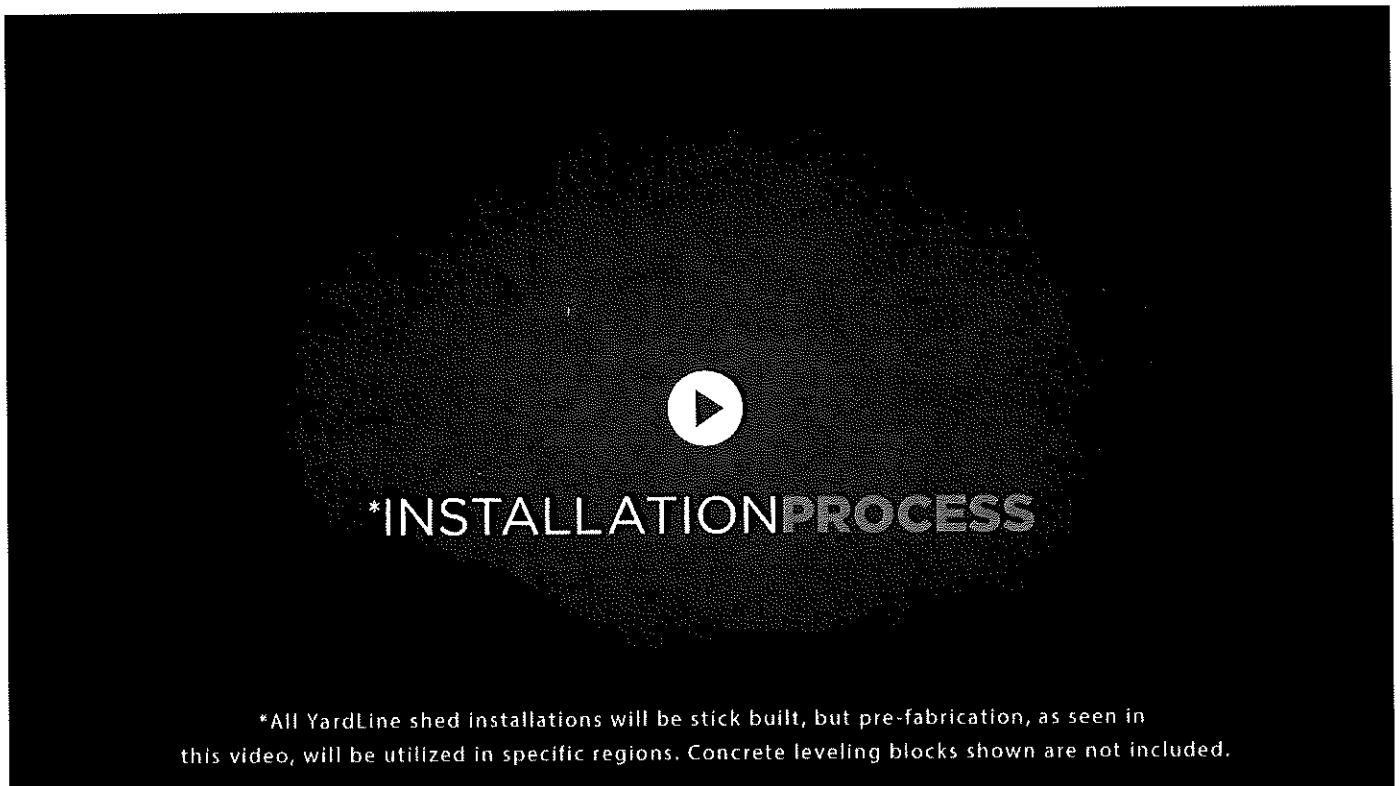

Feedback

DELIVERY AND PROFESSIONAL INSTALLATION INCLUDED

A professional installer will assemble your shed, along with optional accessories. Installation on a properly prepared site takes up to two days.

ABOUT OUR INSTALLERS

- 4.6 average installer rating
- 5,665 sheds built in 2019
- Trained through our network of manufacturing partners
- Will review your order before and after your shed is assembled to ensure 100% satisfaction
- Carefully screened, fully licensed (where required) and insured
- Customer rated to make sure they make the grade to install for us

QUESTIONS?

Email us at customerservice@yardline.net.

THINGS TO KNOW

IT'S MORE THAN JUST A SHED
YOUR SHED IS WHAT YOU MAKE IT

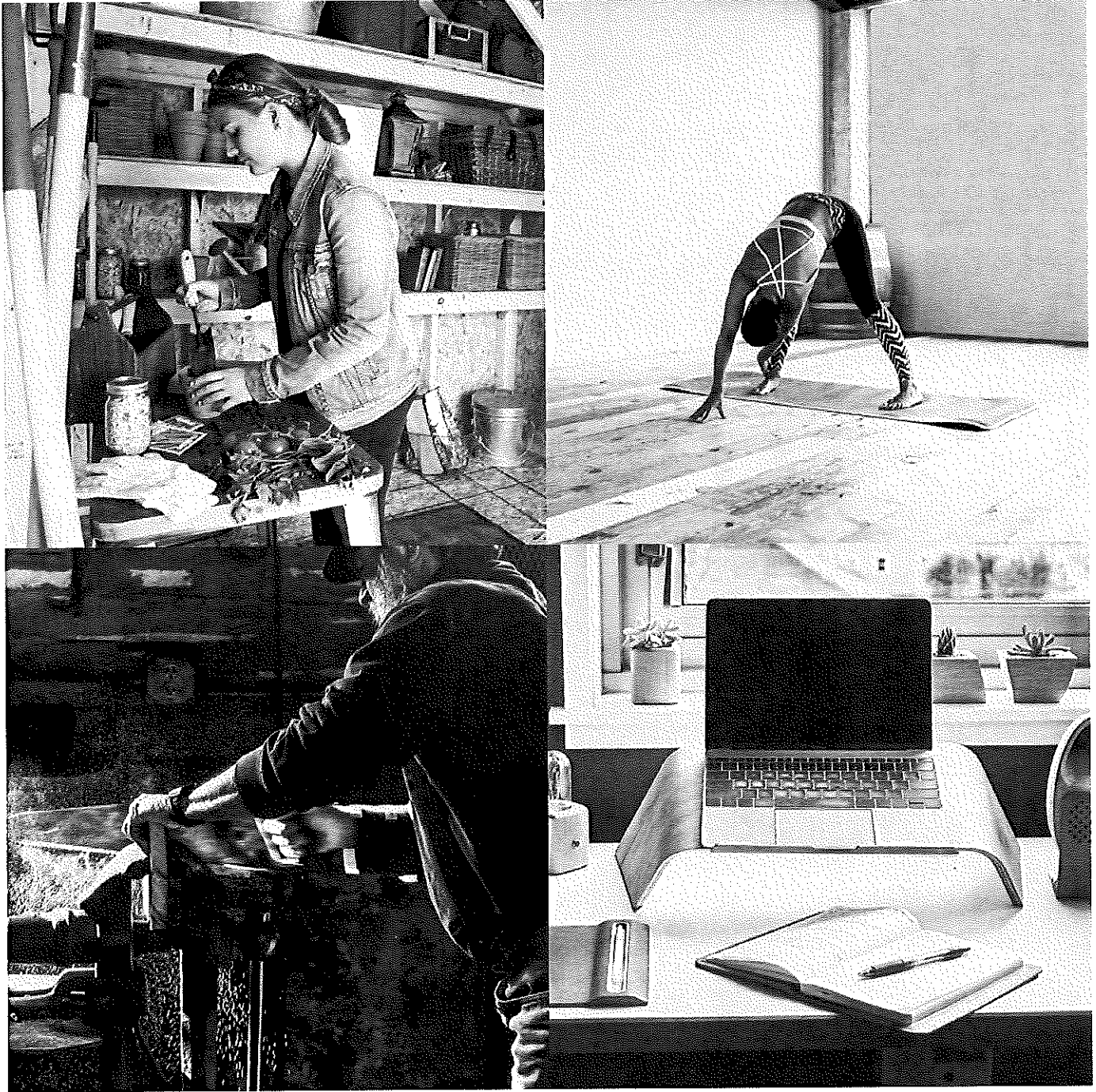

Feedback

SHINGLES INCLUDED

- Choose a color to match your home or unique taste
- 3-tab shingles with a 25-year warranty
- Shingle color chosen during scheduling phone call.
- Actual shingle colors may vary from sample shown.

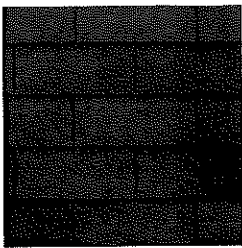

BLACK

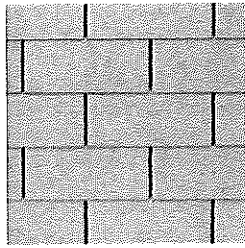

WHITE

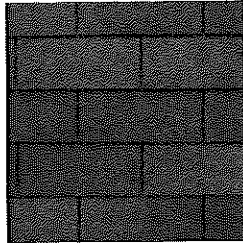

DRIFTWOOD

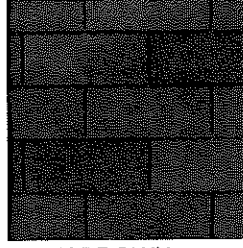

DARK BROWN

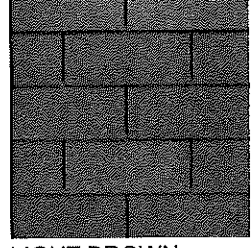

LIGHT BROWN

SPECS

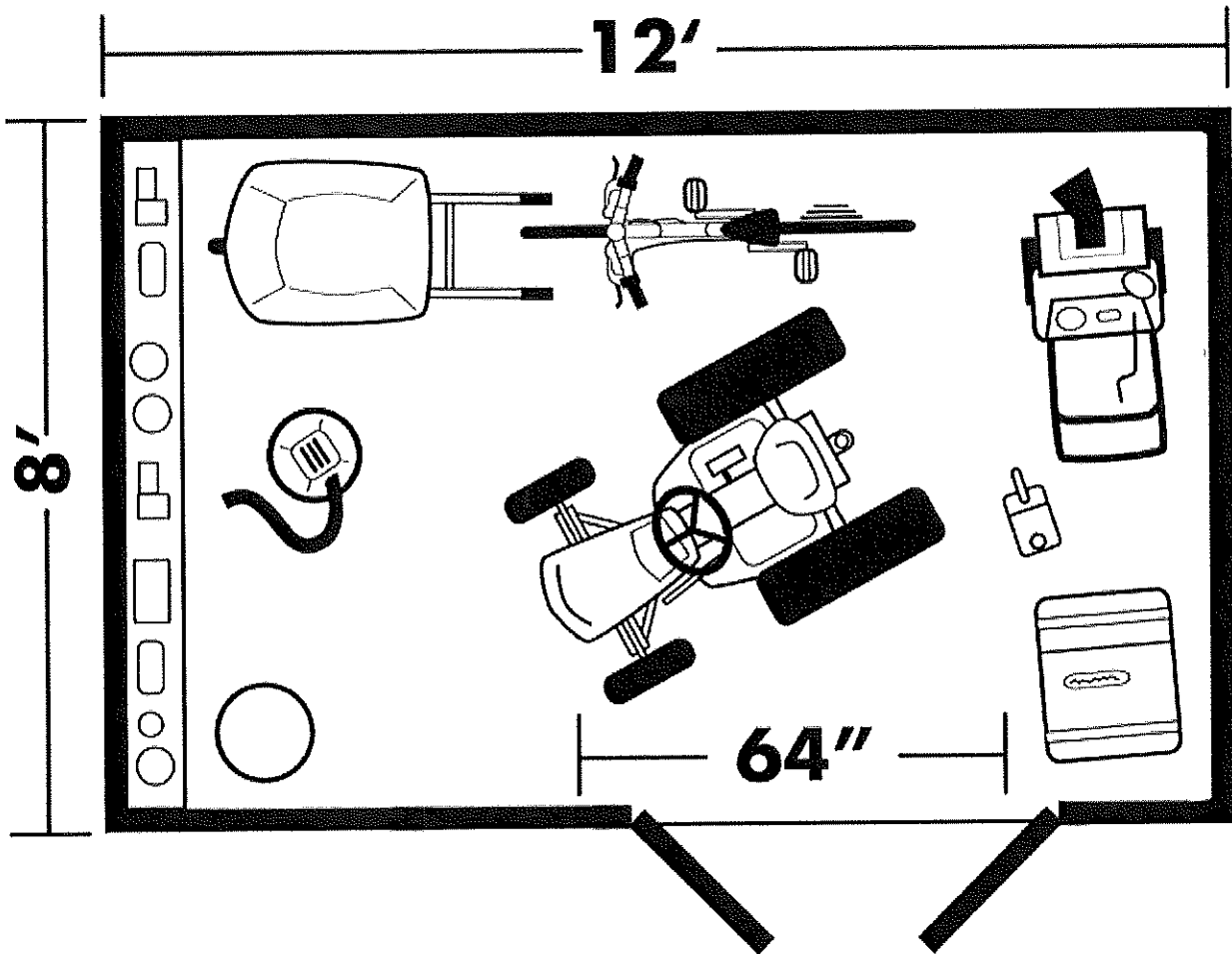

- **Common Size:** 12'W x 8'D x 8'10"H
- **Actual Interior Dimensions:** 12'W x 8'D
- **Cubic Feet Storage:** 716
- **Floor size:** 12'W x 8'D
- **Recommended Concrete Slab Size:** 12'W x 8'D
- **Type of Floor:** Treated Frame & OSB Decking
- **Floor weight capacity:** 40 lb/square foot
- **Peak Height:** 9'3"
- **Sidewall Height:** 6'4"
- **Double Door Opening Width:** 64"
- **Double Door Opening Height:** 70"
- **Wall Framing:** 2 x 4
- **Joist Spacing:** 16" o.c.
- **Stud Spacing:** 24" o.c.
- **Number of Rafters:** 5 sets
- **Rafter Spacing:** 24" o.c.

- **Shelf:** 8'W x 12"D
- **Loft:** 8'W x 21"D
- **Overhang Length (Front):** 4.25"
- **Overhang Length (sides):** 1.75"
- **Assembled Weight:** 1,832 lbs.
- **Type of Vent:** Wall vents (2)
- **Aluminum Threshold:** Included
- **Continuous Piano Hinges:** Included
- **Type of Handle:** Locking T handle
- **Warranty:** Limited 15-year warranty
- **Roof Style:** Ranch
- **Roof Pitch:** 6.5/12
- **Maximum Roof Load (lb./ sq. ft.) :** 30 lb.
- **Maximum Wind Resistance (mph) :** 90 mph

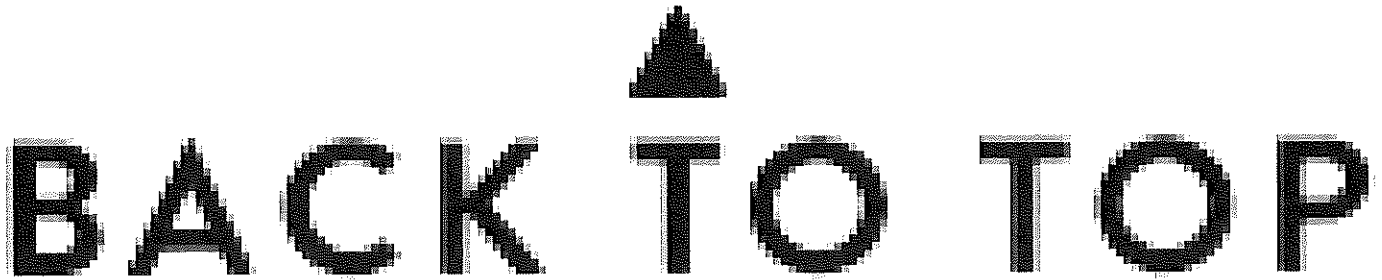

[View More](#)

Feedback

Specifications

Brand	Yardline
Collection Name	Aberdeen
Option	Without Paint Service
Structure Size	8 ft. x 12 ft.

Manuals & Guides

[More Special Events](#)

Shipping & Returns

Special order merchandise, custom merchandise and installed merchandise cannot be returned or refunded after the expiration of your three business day right-to-cancel period. This is an exception to Costco's standard return policy.

The estimated delivery time will be approximately 6-8 weeks from the time of order.

Standard shipping with professional installation is included in the quoted price. Professional installation will require 1-4 days to complete. Please include a daytime phone number in the shipping information at the time of checkout and please monitor your emails for an opportunity to set your delivery appointment. Installation date must be scheduled within 90 days or the order will be subject to cancel and refund issue. Extraordinary delivery requirements may necessitate an additional fee to the carrier.

Installation Requirements: